

Computer-aided Planning and Building Process

vorgelegt von
Master of Science
Salem Buhashima Abdalla-Salem
aus Libyen

an der Fakultät VI Planen Bauen Umwelt
Institut für Architektur
der Technischen Universität Berlin
zur Erlangung des akademischen Grades

Doktor der Ingenieurwissenschaften
- Dr.-Ing. -

genehmigte Dissertation

Promotionsausschuss:

Vorsitzender: Prof. Dr. rer.-nat. Rudolf Schäfer, TU Berlin

Berichter: Prof. Dr.-Ing. Klaus Rückert, TU Berlin

Berichter: Prof. Dr. techn. Karl-Heinz Bruhnke, Universität Leipzig

Tag der wissenschaftlichen Aussprache: 19. August 2009

Berlin 2009

D83

Acknowledgements

This work would not have been possible without the help and support of Professor Rückert to whom I am very grateful. He provided me with many helpful suggestions, important advice and constant encouragement during the course of this research.

I also would like to express my sincere gratitude to professor Bruhnke for being part of this research.

Special thanks are due to my entire colleague at the department of Design and Structural, in particular the department secretary Angela Isfort who was always there to help. Indeed, I would like to thank anybody who has helped me by any means in achieving this research.

My grateful thanks go out to my family whose constant encouragement and support has gotten me through this research.

I cannot end without thanking my country “Libya” for supporting me throughout my study.

Thank you all

Salem Buhashima Abdalla-Salem

Berlin, 2009

Table of Contents

1	Introduction	1
2	State of the art of AEC digital planning (2006)	5
2.1	BIM Applications within the AEC	14
2.2	Questionnaire surveys.....	15
3	Sharing data among the AEC industry - Software Compatibility & Interoperability issues	19
3.1	Introduction	19
3.2	Objective.....	21
3.3	Method and Procedures	22
3.3.1	Exporting elements form MicroStation V8 to Nemetschek Allplan 2004.....	25
3.3.2	Exporting elements form MicroStation V8 to Architectural Desktop 3.3	31
3.3.3	Exporting elements form Allplan 2004 to MicroStation V8	42
3.3.4	Exporting elements form Allplan 2004 to Architectural Desktop.3.3	51
3.3.5	Exporting elements form Architectural Desktop 3.3 to MicroStation V8	58
3.3.6	Exporting elements form Arch. 3.3 to Nemetschek Allplan 2004.....	61
3.4	Conclusion and discussion.....	65
4	VIRTUAL CITY EXAMPLE (VRCE).....	69
4.1	Introduction	69
4.2	Objective.....	72
4.3	Developing VRCE 2D plan	73
4.4	Developing the VRCE Models	77
4.5	Visualization Tools and Methods	81
4.5.1	The CAVE.....	81
4.5.1.1	Loading the VRCE to the CAVE.....	82
4.5.1.2	Problems and issues observed during visualization.....	83

4.5.2	PC Screen Visualization (MicroStation).....	84
4.5.2.1	Advantages and disadvantages of onscreen visualization	86
4.5.3	Google Earth Tools	87
4.5.3.1	Loading the VREC to Google Earth.....	88
4.5.3.2	Advantages and disadvantages of Google Earth visualization	95
4.6	Conclusions	97
5	Building Information Modeling (BIM).....	99
5.1	Background.....	99
5.2	Objective.....	101
5.3	What is BIM?.....	101
5.4	Benefits of employing BIM	106
5.4.1	Benefits during the design phase.....	109
5.4.2	Benefits during the construction phase	112
5.4.3	Benefits during the management phase.....	114
5.4.4	Benefits during Construction handover	116
5.4.5	More BIM benefits.....	119
5.5	Barriers to the adoption of BIM in the AEC industry.....	122
5.5.1	Transactional Business Process Evolution.....	124
5.5.2	Computability of Digital Design Information	126
5.5.3	Meaningful Data Interoperability.....	126
5.6	BIM Production	129
5.7	BIM Software Solutions and Tools	131
5.7.1	Bentley	132
5.7.2	NavisWorks	133
5.7.3	Google SketchUp.....	134
5.7.4	Autodesk	134
5.7.5	Vico.....	135

5.7.6	Tekla.....	136
5.7.7	Nemetschek	136
5.8	Types of BIM	137
5.8.1	First category: BIM according to Participants.....	137
5.8.1.1	Single BIM (x1).....	137
5.8.1.2	BIM (x2).....	138
5.8.1.3	BIM (x3).....	139
5.8.1.4	Multiple BIM.....	140
5.8.2	Second category: BIM according to Tools	141
5.8.2.1	Object-Oriented CAD systems (OOCAD).....	141
5.8.2.2	Parametric building modelers	143
5.9	BIM issues and standardizations	145
5.9.1	NBIMS (National Building Information Model Standard).....	146
5.9.2	IFC (Industry Foundation Classes).....	148
5.9.3	CIS/2 and IFC.....	150
5.9.4	NSC (The United States National CAD Standard).....	152
5.9.5	COBIE (Construction Operations Building Information Exchange).....	153
5.9.6	SDNF (Steel Detailing Neutral Format).....	154
5.10	Related Work (Real life situations and examples)	155
5.10.1	U.S. Army Corps of Engineers (USACE) is going BIM.....	155
5.10.2	New innovative office building in the heart of Vilnius, Lithuania	157
5.10.3	Denver Art Museum Expansion	160
5.10.4	Park Hospital in Novi, Michigan.....	162
5.11	Case Studies.....	164
5.11.1	Hilton Aquarium, Atlanta, Georgia:	165
5.11.2	One Island East Project, Hong Kong:.....	166
5.12	Conclusion.....	167
5.12.1	Who Owns BIM?.....	167

5.12.2	Work in a Multidisciplinary Coordination.....	168
5.12.3	Legal and Liabilities Issues.....	168
6	A proposed BIM System.....	173
6.1	System Architecture.....	174
6.2	System components	176
6.2.1	System Input	176
6.2.1.1	Architectural model.....	176
6.2.1.2	Structural model.....	176
6.2.2	System Output.....	178
6.2.2.1	Visualization	178
6.2.2.2	Documentations.....	179
6.2.2.3	Drawings and Models.....	179
6.2.3	The proposed BIM System in Action.....	180
6.2.3.1	Extracting visualization from the BIM.....	180
6.2.3.1.1	On-Screen Visualization.....	181
6.2.3.1.2	Google Earth Tools.....	185
6.2.3.1.2.1	Visualizing the BIM in Google Earth Environment	185
6.2.3.1.3	3D Model in PDF Files (PDF Images)	190
6.2.3.1.3.1	Inserting BIM into a PDF document	191
6.2.3.1.3.2	Advantages and disadvantages of 3D plot in PDF	192
6.2.3.2	Extracting Documents from the BIM.....	194
6.2.3.2.1	Quantity take-off (Quantity Estimates).....	195
6.2.3.2.2	Reinforcement Details and Specifications	203
6.2.3.3	Drawings and Models.....	204
6.2.3.3.1	Architectural Drawings.....	205
6.2.3.3.2	Structural Drawings.....	207
6.2.3.3.2.1	Reinforcement Drawings.....	207
6.2.3.3.3	3D Models	210
7	Discussing the results.....	211
7.1.1	Outputs break down	213
7.1.2	Distributing BIM results among targeted disciplines.....	215

7.1.2.1	Results for Architects	215
7.1.2.2	Results for Structural Engineers	217
7.1.3	Managing Changes and Modifying Process	218
7.2	Conclusion.....	220
8	Overall Conclusions and Recommendations	223
8.1	Recommendations	225
9	References and Bibliography	
10	List of Figures	
11	List of Tables	

1 Introduction

In this dissertation, I wish to investigate and evaluate current state of computer aided planning and building process in today's Architecture, Engineering and Construction (AEC) industry activities. It is a descriptive work of newly emerging technologies and approaches to design, construction and facility management that offer a great potential of enhancing productivities, reducing project cost and project delivery time and improving cooperation and communication between project's participants. Thereby, a much higher degree of co-ordination and communication is anticipated during the constructing of a project from design to actual construction to finally handing the building to a facility manager.

While these technologies are opening up new methods of communication and collaboration between projects' participants that were just not possible a few years ago, they are far from fully utilized and advantages/benefits are not fully realized by the AEC industry. Therefore, the main focus of this research is to provide an in-depth understanding of these newly emerging technologies and approaches, issues associated with their implementations, and their impacts and effects on the AEC industry's individuals and organizations.

The aim is to discuss two of the most promising techniques that have huge impact on the AEC industry productivity and performance which are virtual reality (VR) and building information modeling (BIM). However, both techniques are based on computer's applications which are generally developed independently by different vendors with different set of goals; and this is coming rather cumbersome and

detering the industry away from full acceptance. Partially, in the case of CAD applications that are redirected for VR purposes which are widely used by the AEC industry. Typically, these applications (software) are developed solely by vendors who are mostly focusing on getting nice pictures and aiming to reduce rendering time required, and not thinking enough about sharing the data with other similar applications. This has promoted hundreds of tools and applications that promise compatibility but not full compatibility as they claim which held back the AEC industry as a whole from gaining full advantages and benefits awaited.

Therefore, interoperability, compatibility and data-sharing among the AEC participants will be the subject of chapter three of this dissertation. The focus is to explore some of the most commonly encountered CAD tools that are widely used in the AEC industry to demonstrate and elaborate on communication and data sharing issues. Mainly, software applications those are locally available at Berlin University of Technology (TUB).

Chapter four will focus on VR implementation within planning and development process. The motive is to explore existing virtual cities approaches and examples, whereby a Virtual Reality City Example (VRCE) will be developed and explored. The VRCE is based on "Hashtgerd Newtown" 2D plans which are available through an educational agreement between the Building and Housing Research Center (BHRC) in Iran and the TUB to establish collaboration on academic and research related development activities. The aim is to develop a 3D-city-example to illustrate and demonstrate new visualization ways and methods that are now available through emerging technologies and applications including, Google Earth, the CAVE, etc.

Building Information Modeling (BIM) definitions, background, and implementation issues and effects will count for chapter five. BIM is not only changing the way buildings look, function and built, it is supposed to be the only source of information about a building from planning through construction to its future management. It also promises the production of high quality construction documents, predicting performance, cost estimation and construction planning. Hence, BIM is a building model based technology linked with a database of project information to enable seamless communication between all stakeholders associated with the construction process. However, there are considerable benefits and advantages BIM can offer which will be discussed in more details throughout this chapter as well as disadvantages and obstacles. Also, other peoples experience, case studies and examples of successful projects which has been drawing from a range of sources, will be provided and discussed as well.

In chapter six, a BIM system will be proposed based on a proposed modern office building in Iran to generate building abstractions such as plans, sections, elevation, details, and schedules. The proposed BIM system will consist of two 3D models of the office building (architectural and structural models) which will be designed and developed using Bentley's MicroStation TriForma software. This chapter explores the proposed BIM system in which several documents and views will be extracted directly from the system using various approaches and methods.

Discussing the results and findings of the proposed BIM system will be presented in chapter seven as well as categorizing the results according to disciplines and providing an overall system outputs chart. In addition, the most encountered issues and difficulties that obstruct BIM adaptations and endorsement industry wide will be discussed.

Finally, a brief conclusion on the effect of these new emerging technologies on the AEC industry and how the industry is coping with them is to be presented including final thoughts and recommendations.

2 State of the art of AEC digital planning (2006)

The AEC industry has been using CAD for a long time now, but that is only electronic drafting. While the advantages of CAD have been well established and proven including efficiencies in drawing reuse, organization, revisions, quality and consistency, etc. it is only an electronic pencil and paper [10]. Though, CAD has greatly expedited the process of drawing production and significantly improved the accuracy of drawing over traditional methods, these drawings and documents are not “intelligent” which store information about the building systems and components [63]. In addition, CAD describes a building by independent 2D views such as plans, sections and elevations which mean editing one view requires that all other views must be checked and updated. This process is prone to errors as well as a major cause of poor documentation [73]. Considering the large number of people and documents involved in a construction project these are some of the issues related to the use of IT within the AEC industry [49]:

- During the design phase:

Usually a construction project starts with the architect who proceeds through a series of phases including schematic design, design development, and contract documents. Next with the help of other project team, the structural, HVAC, piping, and plumbing components are designed. Then, the final set of drawings is sent out to contractors for bidding. In most cases the winning contractor, before work begins, has to redraw some of the drawings to reflect the construction process and the phasing of the construction work. Also, the subcontractors and fabricators must generate their own “shop drawings” to reflect

accurate details of certain elements, such as precast concrete units, steel connections, wall details, piping runs, etc. However, if these drawings are inaccurate or incomplete, or if they are extracted from a drawing that already contains errors or inconsistencies, then expensive and time-consuming conflicts occur in the field.

- *During the construction phase:*

The inconsistency, inaccuracy, and uncertainty in the design phase make it difficult to fabricate materials offsite. Therefore, most fabrication and construction must be done onsite and only when certain conditions are well known. This is costly, time consuming and prone to errors process that would not occur in a factory environment where cost and quality are better controlled. Additionally, several changes are made to the design during the construction phase due to previously unknown errors which need to be resolved by the project's team. This involves a "request for Information (RF) which must be answered by the architect and a "change of Order (CO) to notified all impacted parties about the changes. In fact, these changes and resolutions usually lead to legal disputes, promotes extra costs and delays.

- *During the management phase:*

After the construction is finished, the final contractors and drawings are produced to reflect the as-built changes, which are handed to the owner along with all manuals for installed equipment. However, this information is conveyed to the owner in 2D (on paper) which the owner must invest a great deal of effort to relay all relevant information to the facility management team charge with the maintenance and operating the facility.

In addition, the great number of participants involved in the planning and construction of a project makes communication and coordination a complex process to deal with [23]. Much effort has been put into facilitating communication and collaboration among participants in a construction project. In fact, the AEC industry is realizing this issue and has been in general investigating and investing into ways, techniques and approaches to improve collaboration and communication among project's team. This has led to BIM as one of the most promising development in the AEC industry. Goldberg [71] stated that: *"We can't discuss digital design in the AEC industry without mentioning BIM"*. Thus, BIM is the best example of emerging new technology today which is expected to drive the AEC industry towards a "Model Based" process and gradually move the industry away from a "2D Based" process. The "Model Based" process is where the building will be built virtually before even actual construction starts and it is also called Virtual Design and Construction (VDC) [70].

Using BIM (sometimes referred to as digital models) during the design phase enable the design team to resolve systems-integration problems during design, long before the project goes into construction in which potential cost savings is realized [28]. Obviously, having all project data in a single, updatable database would make data and accuracy easier to manage and integrate all aspects of the project during the design phase [27]. This also should provide contractors and construction process participants during the construction phase more complete as well as more effective representation of design intent. It also means, there is a greater chance that the finished project will look like the completed 3D model [16]. In addition, DeStefano [18] believes that there is also the opportunity to import a digital model directly into a fabricator's shop drawing applications in which this data can be also used to drive automated fabricating machinery and eliminate paper

shop drawings. This allows fabricators to reduce waste because of optimization of tasks such as cutting of sheet metal and pipe can benefit from all scrap pieces.

As a management tool, the designer could generate data from the model for use in calculating a wide range of performance, such as heat/loss gain, day lighting effects, air flow, emergency routs, structural performance and financial feasibility which means creating a closer linkage between analysis and design process [31]. Smith [13] implies that once the digital model of a facility is completed it will be delivered to the operator and sustainer of the facility and any modifications or improvements will be recorded in the model. Thus, the model is the reliable source and will be utilized throughout the life of the facility to plan and tackle any modifications and changes.

However, while utilizing BIM software and tools is quickly becoming commonplace among design architects, many structural engineers are hesitant to tackle three-dimensional representation of large, complex projects. In fact, BIM has not been accepted without reservation in the AEC community, especially by structural engineers who do not see an immediate need to make the switch because their general clients are architects and contractors who are already used to visualizing projects from 2D drawings; even though embracing BIM by structural engineers firms can streamline efforts and eliminate errors. On the other hand, BIM is being quickly endorsed by architects as a way of presenting their work in an easy-to-understand format to owners and developers who are usually not able to read plans.

Traditionally, engineers would design 3D model of the project before even considering loads and seismic issues, then drafters would build a 2D model to incorporate elevations and details. Now, using BIM, drafters and engineers are sharing the same model to supplement it

with their data which integrates drafting and engineering processes, as both teams share the same 3D model.

However, bringing BIM in a firm requires skilled staffs that can perfect the tool which requires a great amount of training effort, since skill set is different from commonly used drafting programs requirement. Firms realizing that a considerable effort of training is necessary to endorse BIM technology; although, the learning curve and associated costs will be steep in addition to significant software costs and new hardware that are required such as bigger screens. AGC [70] published a guide to BIM for contractors, which implies that generally companies are accepting the initial cost and loss of productivity associated with initial learning curve. Thus, firms who have succeeded the initial learning process (6 to 8 months) experience such benefits including improvement in productivity, lower warranty costs, fewer field errors and corrections, etc. These advantages offset the costs with time and could actually reduce them. Additionally, there are software tools that combine models produced in different design packages into one file, to be viewed as one composite model. However, the use of BIM does not have to include the entire project, whereas in some cases, many contractors who are involved in projects with intelligent models do not even realize that. In fact, many designers, suppliers and contractors are using digital models for their own benefit and not sharing the data with other project participants. Therefore, the use of BIM is encouraged even for a certain portion of the project, such as the structural steel or the mechanical systems.

One company Cary Kopezynski & Co. (CKC) is using 3D modeling approach in the design of the 20-storey Hyatt tower in downtown Bellevue for the first time on any of its projects. In fact, project's architect and general contractor are using BIM tool as well, allowing for a collaborative work that has been highly valuable on a project with

a detailed design and a number of complicated connections. The number of complex connections associated with the design, as well as other construction activities on site, proved the use of BIM to be even more appropriate. This could have been achieved using traditional 2D drawings but would have required much more effort. Designers were able to study different design ideas and thoughts before extracting the details and studying the plan using BIM. In addition, using BIM has helped designers to avoid structural conflicts with adjacent buildings by identifying common foundation footings and other shared elements. However, many project components, such as floor models, still require 2D drawings as well as moving back and forth between 3D and 2D drawings which has been more challenging than expected. Also, line weights which represent certain components in the plan are not conveyed by the BIM to the 2D drawings correctly requiring considerable efforts to correct. What is more, sharing drawings with other project participants has proven to be a difficult task not as simply attaching a file to an email document [65].

Also, Condon [68] acknowledges that with its clear benefits and cost savings opportunity, BIM is not widely spreading among engineers and managers. One reason is during the design and construction phases, architects, engineers, and construction managers are not willing to spend time in creating a BIM that does not substantially help them to accomplish their jobs; but will be useful in the operations phase. Also, they are discouraged by absence of universal standard for digital design drawings. Now days, there are many different proprietary format with varying levels of functionality which hinder widespread of BIM. For example, a 3D model developed using one software package may not be usable in another company using different software package. Therefore, developing a universal BIM format that can be useable by other software programs will be a significant challenge. He also argues

that many architects are using CAD software just as a way of producing a “picture” for printing on paper. In fact, until architects start using CAD to its fullest capability, BIM will not be a reality. However, facility owners and managers who will be benefiting most from BIM are able to apply the pressure needed for all project team to adopt and use BIM standard. Meanwhile, support for BIM technology among owners and managers has been slow due to a lack of information and understanding. Now this is changing because one of the largest facility owners in the world (the United State government) is committed to gaining benefits offered by BIM. However at an international level, it will undoubtedly take years to evolve fully and be widely adopted although remarkable progress has been achieved by the National Institute for Building Sciences (NIBS) at the end of 2006 to form the National BIM Standard (NBIMS).

Many believe that the problem of BIM and overall consensus involved was not in the technology or in learning it, but rather the change of the business process that result from transition to BIM. An estimated 70% of the change required to bring BIM to a firm is going to be cultural, while the technology part will be only 30% of it. Example of firms experiencing transition to BIM is the GSA (US General Services Administration, the largest builder-owner of federal projects in the USA). The size of the company causes them to move slowly towards BIM however, they are trying to be as adaptive and flexible as possible and are committed to BIM. Another practical example is driven by Walt Disney Engineering who experiencing simplicity in transition to BIM in the last 18 months (as of writing of this article) due to the rapidly changing pace of technology. Most likely, this rapid change of technology will accelerate in the future allowing for smoother and easier transition to BIM than is currently anticipated [69].

In fact, the utilization of BIM in the AEC industry to improve the planning, design and construction process is increasingly being referred to as Virtual Design and Construction (VDC). However, whether it is called “BIM” or “VDC”, this is the future of the AEC industry. Stockholders, who haven’t adopted this technology yet, are encouraged to at least start familiarizing themselves with the key terms and current available tools and applications to provide them with a good framework for gathering knowledge on the subject and better endorsement preparation when the time comes. Yet, BIM is a tool which is made available mainly by recent advances in computer hardware and software. It may change the ways a project is viewed, designed and defined, but it will not change the core responsibilities of each member of the project team. Most importantly, the responsibilities of project’s team members remain unchanged and they thoroughly understand the nature, value and precision of the information being conveyed. Now days, BIM tools that can ensure coordination between project participates are available, when applied appropriately costs and construction time are reduced [70].

Surprisingly, not many AEC professionals are aware of the BIM or information extraction trends. Although the AEC industry has long moved to CAD (that is only electronic drafting tool and far from the idea of BIM) handful have pursued full 3D modeling with great vigor, and even fewer adopted BIM and information extraction, even though a great deal of time and money have been invested in BIM by the AEC software industry. This is mainly because of the AEC is familiar with 2D CAD drafting tool and many know how to use them well, whereas, BIM software are much more complex and hard to master. Yet, BIM software solutions increase productivity immensely and provide visualizations, sections and elevation, etc. The author mentioned two major barriers that are blocking the widespread adoption of digital

modeling within the AEC industry. The first obstacle is the liability issue associated with the extraction of digital data directly to product acquisition stream. For example, if the designer (architect) places two items (windows) in the same position and they are order electronically, who would pay for the extra window? In addition to who would pay the architect for the additional effort to produce the digital model? The second hurdle is not the capability of the new BIM software, but it is the training needed to master the program. Already mentioned, BIM software are complex and difficult to master, and professionals usually don't have extra time to implement new BIM solutions. Indeed the new BIM program will usually require a master builder operator – someone who has the knowledge on how buildings are built – but few exist. In fact, experienced AEC persons have good knowledge on how to construct a building; however they are generally don't know how to operate the software productively. Nevertheless, despite these obstacles and hurdles, it's inevitable that the AEC industry will be driven towards 3D modeling and BIM. But the question is how long will it take and which tool will become the industry standard [72].

2.1 BIM Applications within the AEC

Azhar among others [73] and Birx [87] identify the following purposes the AEC industry could use BIM technique for:-

- *Visualization*: visualization is the core of BIM which offers rendered pictures of the project in-house with a little effort.
- *Fabrication/shop drawings*: users can easily extract shop drawings for various building systems, as in the case of the sheet metal ductwork shop drawing which can be quickly produced upon completion of the model.
- *Code reviews*: the BIM model could be used by fire departments and other officials to review their building projects.
- *Forensic analysis*: forensic analysis is made easy by adopting BIM techniques to graphically illustrate potential failures, leaks, evacuation plans, etc.
- *Facilities management*: renovations, space planning and maintenance operations are type of services offered to facility management department by BIM.
- *Cost estimating*: a feature that is built-in BIM software to allow for automatically extracting material quantities and incorporating any changes that made to the model.
- *Construction sequencing*: a BIM can be used to produce material ordering, fabrication, and delivery schedules for all building components.
- *Conflict, interference and collision detection*: since BIM are created to scale, in 3D space, interferences of building systems can be visually checked which can verify that piping does not interfere with steel beams, ducts or walls for examples.

2.2 Questionnaire surveys

Azhar among others [73] discussed the role of BIM in the US construction industry and academia based on the results of three questionnaire surveys as follow:-

The first survey was conducted by Kunz and Giligan [74] to determine the value from virtual design and construction (VDC) or BIM use and factors that contribute to success which yield the following findings:

1. Increase BIM usage across all phases of design and construction during the last one year.
2. BIM is being used by all segments of the design and construction industry which operate throughout the US.
3. Construction documents development, conceptual design support and pre-project planning services among most application areas of BIM.
4. Currently, the use of BIM tools for 3D/4D is dictated by planning and visualization and clash detections.
5. Overall risk distributed with a similar contract structure are reported to be decreased using BIM.
6. BIM helps firms to increase productivity, better of project's team engagement and reduce contingencies.
7. Also reported that there is a lack of skilled building information modelers in the industry and demand will grow over time.

The second survey is conducted by Khemlani [75] to identify the most urgent requirements that AEC professionals would like BIM tools to satisfy which are summarized to the most important 10 requirements as follows:-

- Full support for producing construction document to eliminate the need for other drafting applications.
- Smart objects that can connect and related to other objects.
- Provide object libraries.
- Support multi discipline working on the same project.
- Provide help and supporting documentation, tutorials and other learning resources.
- Ability to deal with large projects.
- Capability to serve multi-disciplinary team (architecture, structural engineering and MEP).
- Direct integration with other tools such as energy analysis, structural analysis and project management programs.
- Full compatibility with Industry Foundation Classes (IFC).

The survey concluded that the AEC industry is still relying on drawings for conducting its activities of designing and construction. However, AEC professionals are also aware of the capability of BIM for more efficient and intelligent modeling by emphasizing on smart objects that maintain connection and relation with other objects as well as the availability of object libraries. Also indicated by participates who required a BIM application that not only leverages the powerful documentation and visualization capabilities of a CAD platform but also to support multiple design and management operations. However, BIM technology is still in the stage of development and application in the market are continuing to evolve as they try to response to user's specific demands.

The third survey was carried out by Dean of the department of building science, Auburn University in 2007 to examine if BIM should be taught as a subject to the construction management students. The survey targeted general contractors and ASC construction management programs in the Southeast. According to responds of participants, the construction management program should teach BIM to their students and here are the main reasons behind this conclusion:

- About 70% of the industry participants either using or considering using BIM which indicate using this technology is going to increase.
- About 75% of survey participants consider hiring candidates with BIM skills over candidates without BIM skills.

3 Sharing data among the AEC industry - Software Compatibility & Interoperability issues

3.1 Introduction

Fragmentation of the Architecture, Engineering, and Construction (AEC) industry is the direct cause of problems and issues related to sharing information among projects participants, especially exchanging design data. Young Jr. among others [1] anticipated the unprecedented technology revolution that the AEC industry is experiencing today. This is marked by the thousands of custom and commercial applications being deployed in uncoordinated way by tens of thousands of firms on over a huge number of projects every year. These applications although powerful as they are in their own right, they held the AEC industry as a whole from gaining benefits because these tools don't pass information seamlessly among themselves. As claimed by Day [83], vendors sell their products on the basis of what they are can do, and when advertising, they exaggerate their capabilities to look very impressive indeed. However, individuals and firms have reported a huge gap between potential and actual use of these applications.

Thus in today's collaborative environment, projects teams are starting to work and communicate more effectively for the overall benefit of both their companies and their projects, so their tools need to evolve to support this new way of doing business. However, there are many design tools evolving today which are used by the AEC industry that promises compatibility but not full compatibility as the claim.

Therefore throughout the last decade, researches in this field focus on the enhancement of interoperability and industry-wide standards to

support the development of industry tools and applications. One of the most recently emerged technologies the AEC has adopted and being discussed here is Virtual Reality (VR) technology. In recent years, the emerging and fast growing (VR) technology has yield several interesting visualization techniques, tools and applications. These include immersive and Non-immersive VR tools such as, HMD (Head Mounted Display, VR glasses, the CAVE (Cave Automatic Virtual Environment), the BOOM (Binocular Omni-Orientation Monitor) etc. as well as several CAD software applications that capable of producing VR environment, such as MicroStation, Nemetschek, 3.3, SuperScape, MultiGen-Pardigm, Autodesk, etc.

However, despite the advances in VR techniques and tools, data exchange between these tools (often refer to as interoperability) is an important issue that hampers the full usefulness of this technology. Lack of interoperability could have great effects on both firms and applications users, in which they could face unexpected problems and heavy costs once it comes to updating or shifting to another application. This mainly due to many different software tools being produced and used by different disciplines that produce data in different file format. In fact, most of these applications do not import or export one another's native file formats [2].

Truly, this could be a time-consuming process and costly maneuver trying to export all existing drawings to a new software and find out that some features or functions do not match or worst, not possible to export to this particular software. Therefore, it is important for the potential construction project manager to gain enough software familiarity to be aware of current issues and developments, and to be able to select the most appropriate tools and be familiar with the software capabilities and compatibility.

Additionally in today's globalized businesses and economy exchanging data, especially design data, is crucial to the success of firms and projects. Because, many firms located in different parts of the world are using variety of software applications and tools, compatibility and interoperability will contribute to the success of their activities. In fact, this issue of compatibility comes to play even within the same firm when different tasks are tackled using different applications.

Therefore, the focus of this chapter is to enhance AEC user's awareness, expectation and prediction to issues that may arise during sharing and exchanging information between CAD applications. Most importantly, users should be informed of these issues in advance and expect that certain elements of their design may not or may export wrongly to another similar applications, although vendors promise full compatibility. The aim is also directed to enlighten AEC practitioners especially managers and software users of the potential problems when sharing and exchanging data with other software applications.

3.2 Objective

This chapter discusses compatibility and interoperability issues of some of the major CAD software applications that capable of VR production which are used widely by the AEC participants. The aim is to raise awareness of data exchange among similar applications as well as exploring characteristics and functionality of some of the most commonly used tools for today's VR production. However, while many VR capable CAD systems and tools are available; this research concerns with software applications that are locally available at Berlin University of Technology (TU Berlin) which are:

- 1) Bentley's MicroStation V8 (Architecture);
- 2) Nemetschek Allplan 2004; and
- 3) Autodesk Architectural Desktop 3.3 Deutsch.

The process will involve solely examining each commands and functions featured by the proposed software to explore compatibility and interoperability issues among these tools. This is achieved in a simple manner by exporting or importing simple object from one application to another.

Finally the results, findings and observation will be recorded in organized tables and will be explained extensively in more details.

However, this process of exchanging and sharing data between proposed applications has taken place from the period of October 2004 until May 2005.

3.3 Method and Procedures

The three proposed software will be investigated and examined in combinations with each other to find out the status of elements (once arrived in the other software) and problems that may occur during the sharing process. These examinations and investigations will relay on exporting and importing elements solely between proposed software in a simple manner. This means, drawing a simple element in one software (for example a horizontal line in MicroStation), exporting it to other software (i.e. to Allplan) and observation is made according to specific examination criteria. This may sound very simple procedure; however a great deal of time and effort is being spent at this stage to determine and compare the status of the element with its original status after sharing it which involves:

- Element identification: how is the element being identified after importation or exportation? What is the name of the element once arrived in the other program.
- Measurement of the element: i.e. measuring the length of exported elements after the exchanging process is part of the observation process.
- Coordination and modification ability of elements: in addition to coordination checks, some elements modification abilities are differ from the origin after exportation or importation.
- Association status of elements: checking hatching and dimensioning association of shared element is a major part of this process.

However, the investigation and examination will include most commonly encountered 2D and 3D elements featured by the proposed software applications. In fact, the exchanging process (fig. 1) will involve the examination of the three proposed application in combination with each other as follow:

- 1) Exporting elements form MicroStation V8 to Allplan 2004.
- 2) Exporting elements form MicroStation V8 to Architectural Desktop 3.3.
- 3) Exporting elements form Allplan 2004 to MicroStation V8.
- 4) Exporting elements form Allplan 2004 to Autodesk Architectural 3.3.
- 5) Exporting elements form Architectural Desktop 3.3 to MicroStation V8.
- 6) Exporting elements form Architectural Desktop 3.3 to Allplan 2004.

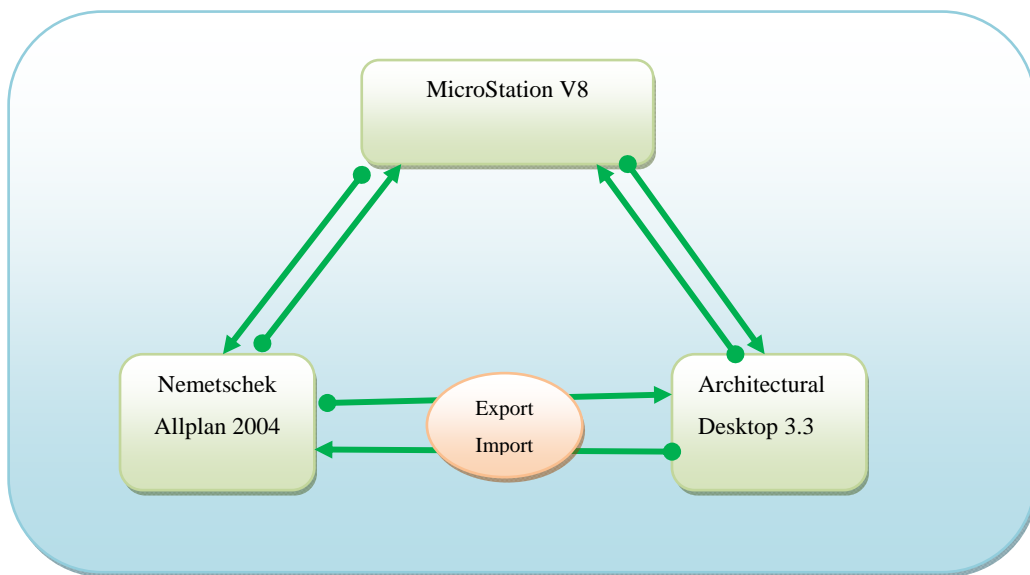

Fig 1: Exporting and importing process between proposed applications

3.3.1 Exporting elements form MicroStation V8 to Nemetschek Allplan 2004.

Due to license agreement, exporting elements from “MicroStation V8” directly to “Nemetschek Allplan 2004” is not allowed; therefore elements produced by “MicroStation V8” must be saved as “MicroStation V7” (older version) in order to continue sharing. However, positively “MicroStation V8” offers save as older version to allow for continues sharing ability with existing applications; on the other hand, it markets a newer version of its software without compatibility consideration with products already on the market.

However, for this examination and investigate process most elements and commands offered by “MicroStation V8” are to be exported to “Nemetschek Allplan 2004” solely one by one. Once arriving in “Allplan”, elements will be observed whether they match the original statues in addition to checking them for certain other criteria as illustrated by the provided table (1) and following figures. Test criteria includes elements first appearance (i.e. 3D wiremesh looks), elements modification allowed and rendering abilities. The following (table 1) is a full list of all tested elements, which are divided into 2D and 3D elements. Furthermore, some figures explaining and illustrating major exchanging problems are provided.

MicroStation	Status of exported elements	Element identified as (in Nemetschek Allplan)
2D Elements		
Linear elements		
Smart Line	Ok	Line
Line (Horiz. & Vertical)	Ok	Line
Multi-line	Ok	Polygon surface
Stream Line String	Ok	Polygon surface
Point or Stream Curve	Ok	Spline with connection
Angle Bisector	Ok	Line
Minimum distance Line	Ok	Line
Line at Active Angle	Ok	Line
Arcs		
Arc	Ok, but behaves as several separate elements	Circle
Half Ellipse	Ok, but no modifications allowed	Polygon surface
Quarter Ellipse	Ok, no modifications.	Polygon surface
Ellipses		
Circle	Ok	Circle
Ellipse	Ok	Ellipse
Polygons		
Block	Ok	Polygon surface
Shape	Ok	Polygon surface
Orthogonal Shape (solid & hole)	Ok	Polygon surface
Regular Polygon (Inscribed, Circumscribed & By Edge)	Ok	Polygon surface
Patterns		
Hatch	Ok	Individual lines
Cross Hatching (with Associative Pattern)	Cross hatching changes to one-way hatching.	Hatch
Cross Hatching (without associative) pattern	Looks Ok, but lost of association.	Individual lines
Dimensioning		
Linear (Horiz & Vertical).	Ok, lost of association	Line & text
Angular	Ok, lost of association	Line & text
Ordinates	Not possible to exchange	
Tags		
Tags	Not possible to exchange	
Texts		
Text	Ok	Text

Note	Ok, but without note leader	Macro
Annotate		
North Arrow	Ok, but no text	Macro
Selection Callout	Ok, but no text	Macro
Building Selection Callout	Ok, but no text	Macro
Detail Selection Callout	Ok, but no text	Macro
Elevation Callout	Ok, but no text	Macro
Detail Callout	Ok, but no text	Macro
Drawing Title	Ok, but no text	Macro
Interior Elevation Callout	Ok, but no text	Macro
Coded Note	Ok, but no text	Macro
Room Label	Ok, but no text	Macro
Door ID	Ok, but no text	Macro
Spot Elevation	Ok, but no text	Macro
Floor Transition	Ok, but no text	Macro
Revision Indicator	Ok, but no text	Macro
Break Line	Ok	Macro
3D Elements		
3D Primitives		
Slab (Solid)	Ok	Cubic
Slab (surface)	Ok	Polygon surface
Sphere (Solid & Surface)	Not possible to exchange	-----
Cylinder (Solid)	Ok	Polygon surface
Cylinder (Surface)	Ok	Polygon surface
Cone (Solid)	Ok, but more lines in wiremesh representation.	Polygon surface
Torus (Solid)	Not possible to exchange	-----
Torus (Surface)	Ok	Polygon surface
Wedge Solid	Ok, more wiremesh lines	Polygon surface
Forms		
Linear Form	Ok, but will not render.	Macro.
Segmented Arch Form	Ok, but will not render.	Macro.
Arch Form	Ok, but will not render.	Macro.
Curve Form	Ok, but will not render.	Macro.
Slab Form	Ok, but will not render.	Macro.
Free Form	Ok, but will not render.	Macro.
Steel Section	Ok, but will not render.	Macro.
Utilities		
Frame Builder	Ok, but will not render.	Macro.
Stair Maker	Ok, but will not render.	Macro.
Truss Builder	Ok, but will not render.	Macro.

Table (1) Exporting elements from MicroStation to Nemetschek Allplan

The above *table (1)* consists of a complete list of “MicroStationV8” commands and elements, which were exported to “Nemetschek Allplan 2004” for compatibility observation. The table (1) consists of three columns representing name of elements in its original program, status of the elements and their identifications after arriving at the other program. However, the main findings and major problems observed during the exchanging process are listed and explained as follow:

- ❖ Modification ability of “arcs” exported from “MicroStation V8” to “Nemetschek Allplan 2004” is totally different. Once exported to Allplan, this arc behaves as separate elements and can be broken into several segments whereas in its original program it behaves as one piece, as shown in *figure (2)*.

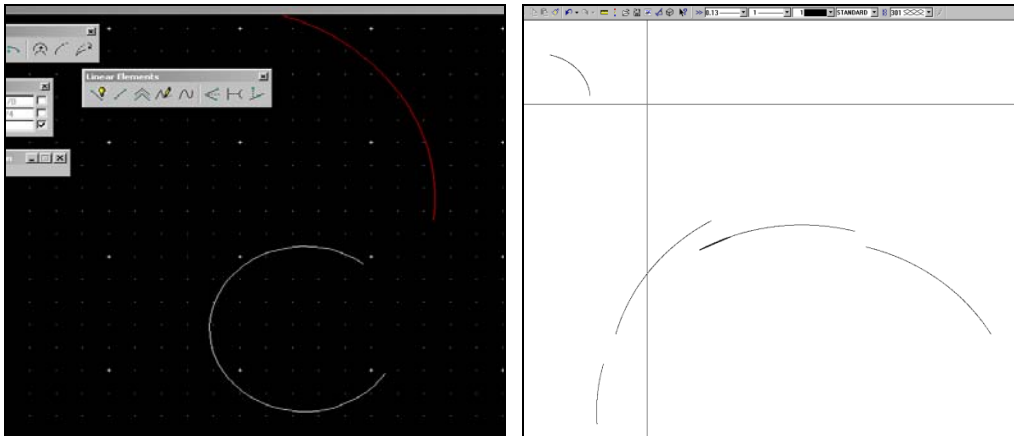

Fig 2: MicroStation arch behaves differently in “Nemetschek Allplan”

- ❖ Loosing dimensioning association is a major setback that hampers the ability of exchanging and sharing data between “Allplan” and “MicroStation”. This is a key concern because modifying or editing these dimensions after arriving in “Allplan” will require manual adjustment that is not required originally.

- ❖ Another worry is the representation of 3D Wiremesh elements which are represented with more lines compared to their original statues. This can lead to misinterpretation and confusions. Although this depends on the setting of the software and how it supposes to present wiremesh, the software should be designed to adapt to the imported file; since not everybody would be able to figure out the problem right away.
- ❖ Moreover, elements association inflicted another crucial problem in the case of hatching. For example “cross-hatched” element exported to “Allplan2004” has lost its association and “cross hatching with associative pattern and associative region boundary” only the outer shape of the element (circle in this case) is represented and the hatching is totally lost as shown in *figure (3)*.

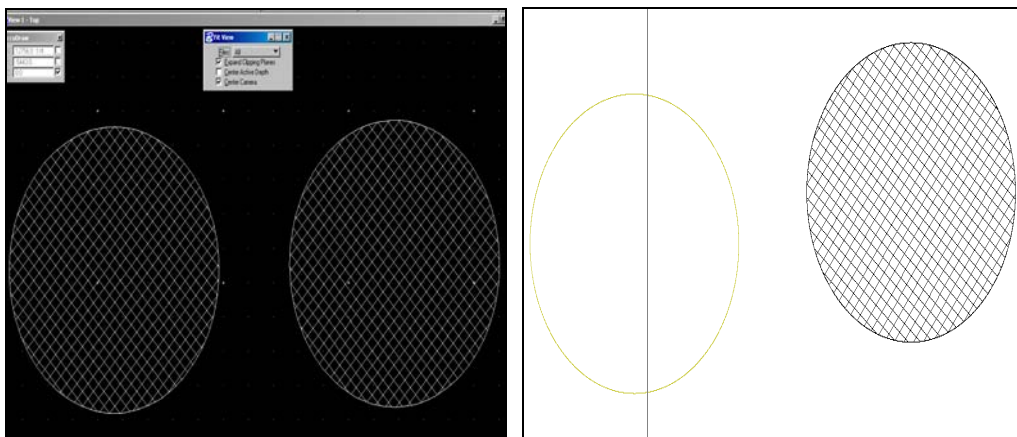

Fig 3: Illustrates lost of hatching in Nemetschek Allplan

- ❖ Also “MicroStationV8” “texts” and “notes” inflicted another sharing problem once imported to “Allplan2004”. The “text” and “notes” associated with the circle seem to disappear in “Allplan as

illustrates by *figure (4)*, and this could be not allowed to import by “Allplan” or “Allplan” is not set to automatically adjust to imported elements. Thus, this has proven to be the case in many other occasions where text and notes were part of the importation process.

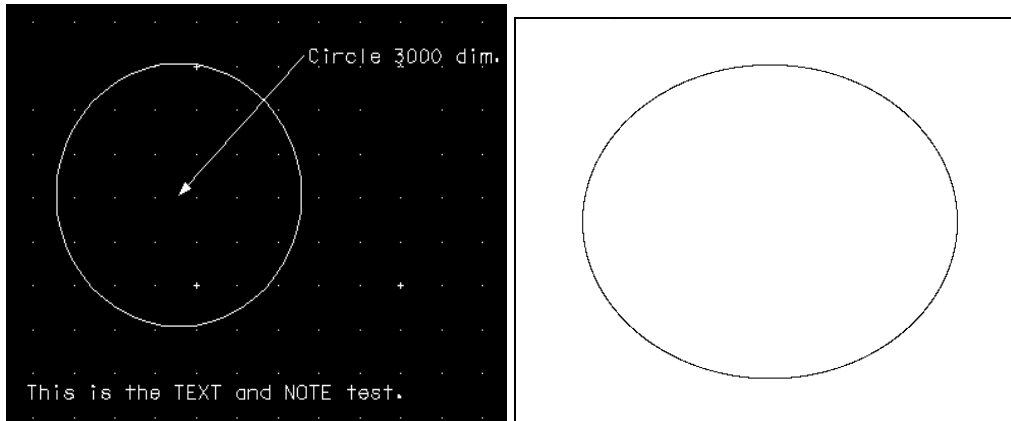

Fig 4: Texts and notes exported from MS disappeared in “Allplan”.

- ❖ Likewise, “linear and Arch-forms” produced in “MicroStation” presented their own problems once opened in “Allplan”. Although they are viewable and preserve their accurate look and size, elements shared between the two applications cannot be modified by any means.
- ❖ Wrong identification of shared elements is another obstacle. All “annotation” elements imported from “MicroStation” to “Allplan” as shown in *figure (5)* are identified falsely as “Micros” in addition to disappearance of associated texts.

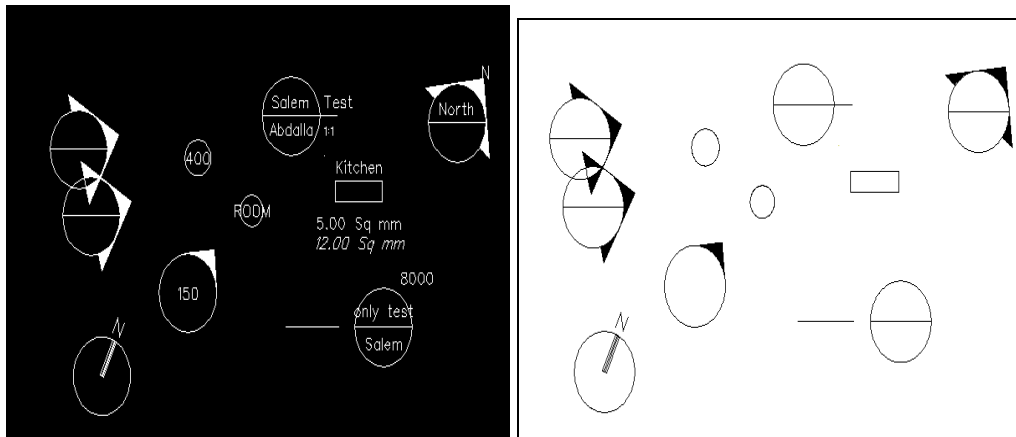

Fig 5: Annotation elements lost their associated text in Allplan (right).

3.3.2 Exporting elements form MicroStation V8 to Architectural Desktop 3.3

Sharing data between “MicroStation V8” and “Architectural Desktop 3.3” does not work as smoothly as in the case of MicroStation with Nemetschek Allplan. Modification abilities of element exported from MicroStation to Architectural Desktop 3.3 is the major obstacle observed throughout this study. Even though, Architectural Desktop 3.3 recognizes MicroStation V8 elements and maintain their exact appearance and measurements, the following table (*Table 2*) illustrates the difficulty and problem regarding exchanging data between the two applications.

MicroStation	Status of exported elements	Element identified as (in CAD)
2D Elements		
Linear elements		
Smart Line	Ok	Line
Line (Horiz & Vertical).	Ok	Line
Multi-line	Ok	Multi-line
Stream Line String	Ok	Polyline
Point or Stream Curve	Ok	Spline
Angle Bisector	Ok	Line
Minimum distance Line	Ok	Line
Line at Active Angle	Ok	Line
Arcs		
Arc	Ok	Arc
Half Ellipse	Ok	Ellipse
Quarter Ellipse	Ok	Ellipse
Ellipses		
Circle	Ok	Circle
Ellipse	Ok	Ellipse
Polygons		
Block	Ok	3D face
Shape	Ok	Polyline
Orthogonal Shape (solid & hole)	Ok	Polyline
Regular Polygon (Inscribed, Circumscribed & By Edge)	Ok	Polyline
Patterns		
Hatch	Ok	Line
Cross Hatching (with Associative Pattern)	Ok	Hatch
Cross Hatching (without associative) pattern	Ok	Line
Dimensioning		
Linear (Horiz & Vertical).	Ok	Dimension(Gedrehte Bemaßung)
Angular	Ok	3D-punkt-Winkebemaßung
Ordinates	Ok	Diametralbemaßung
Texts		
Text	Ok	Text
Annotate		
North Arrow	Ok	Block Reference
Selection Callout	Ok	Block Reference
Building Selection Callout	Ok	Block Reference
Detail Selection Callout	Ok	Block Reference
Elevation Callout	Ok	Block Reference

Detail Callout	Ok	Block Reference
Drawing Title	Ok	Block Reference
Interior Elevation Callout	Ok	Block Reference
Coded Note	Ok	Block Reference
Room Label	Ok	Block Reference
Door ID	Ok	Block Reference
Spot Elevation	Ok	Block Reference
Floor Transition	Ok	Block Reference
Revision Indicator	Ok	Block Reference
Break Line	Ok	Block Reference
3D Elements		
3D Primitives		
Slab (Solid)	Ok, with different modification options.	Vielflächennetz
Slab (surface)	Ok	Polygon
Sphere (Solid)	Looks different	
Sphere (Surface)	Looks different	3D-volumenkörper
Cylinder (Solid)	Ok	3D-volumenkörper
Cylinder (Surface)	Ok	Circle
Cone (Solid)	Ok	3D-volumenkörper
Cone (Solid)	Ok	3D-volumenkörper
Torus (Solid)	Ok, different wiremesh representation	3D-volumenkörper
Torus (Surface)	Ok, different wiremesh representation	3D-volumenkörper
Wedge (Solid)	Ok	3D-volumenkörper
Wedge (Surface)	Ok	Polygon
Forms		
Linear Form	Ok	Block Reference
Segmented Arch Form	Ok	Block Reference
Arch Form	Ok, but rendering problem.	Block Reference
Curve Form	Ok	Block Reference
Slab Form	Ok, rendering problem	Block Reference
Free Form	Ok, rendering problem	Block Reference
Steel Section	Ok, rendering problem	Block Reference
Utilities		
Frame Builder	Ok	Block Reference
Stair Maker	Ok	Block Reference
Truss Builder	Ok, same modification functions	Block Reference

Table (2) Exporting elements from MicroStation to Arch. Desktop 3.3

Table (2) has listed in details the status of different elements and commands as they passed from MicroStation to Architectural Desktop. Although most elements were exchanged between the two applications without major changes, some elements pose the following problems:

- ❖ MS “Spline” exported to “Architectural Desktop 3.3” does not look like its original status as shown in *figure (6)*; however modification did not impose any problem since it can be modified in the same way as the original Spline.

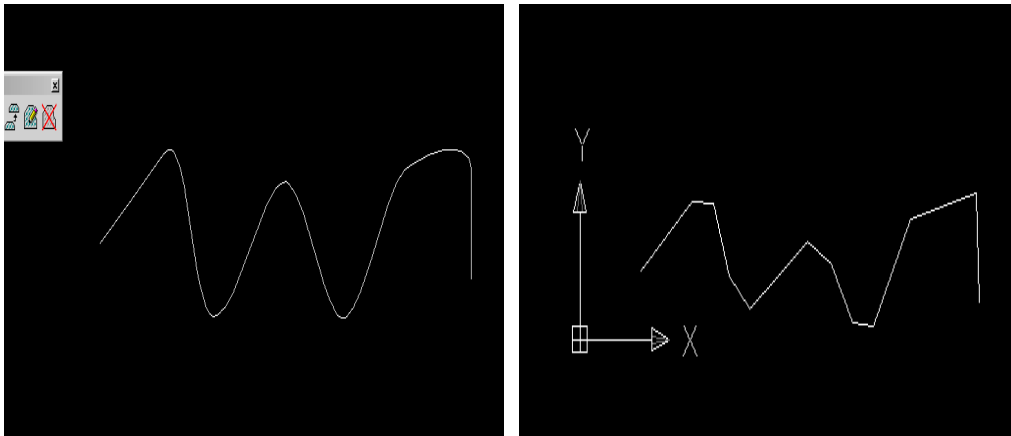

Fig 6: Spline does not look as smooth in Arch. Desktop 3.3

- ❖ Appearance problems. A Circle imported from “MicroStation” to “Architectural Desktop 3.3” has maintained the same measurements (i.e. radius value), however first appearance differs from the original as *figure (7)* illustrates; again this is due to the initial settings of the receiving application.

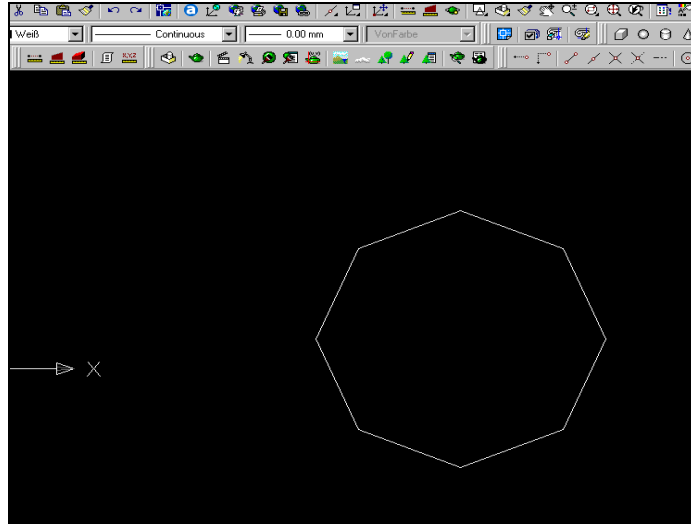

Fig 7: Circle does not look as smooth in Arch. 3.3

- ❖ False identification of hatching by “Architectural Desktop”. Even though, “associated-hatch” was recognized correctly as hatch once opened in “Architectural Desktop 3.3”., hatching without association were identified as lines and behaves as individual lines. However, imported associated hatching seems to function normally in “Desktop3.3” with the exception of “region boundary hatch” which is offered by MicroStation and not recognized by “Desktop 3.3”.
- ❖ Modifications not permitted. “Multi-lines” exported from MicroStation to Architectural Desktop did not allow for any modifications.
- ❖ Again, “Linear form” exported to “Desktop 3.3” from “MicroStation” escalates another hindrance that obstructs data exchanging ability between the two applications. “Linear forms” allow for very little modification once opened in “Architectural Desktop”; in fact, it can only be modified from one point, whereas in “MicroStation” it has

several modification options including enlarging and shrinking it.

- ❖ In the next two figures (8 & 9) the seriousness of the problem imposed during data sharing between the two applications could be clearly notified. The two cylinders were drawing in MicroStation and exported to Architectural Desktop afterword in which astonishing results occurred. They appear attached to each other and the original distant between them has been omitted. In addition the two cylinders rendered both as solid objects although the smaller cylinder supposes to be a surface objects (figure 9).

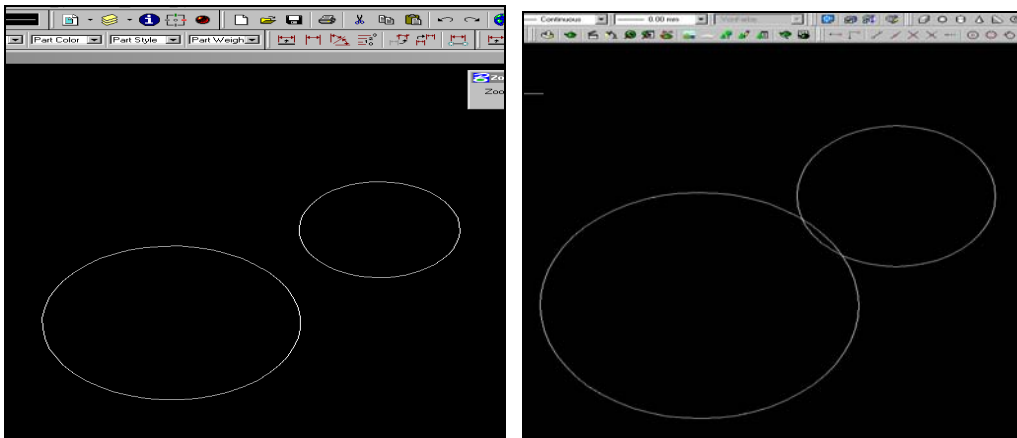

Fig 8: The two cylinders are attached in Arch. Desktop 3.3

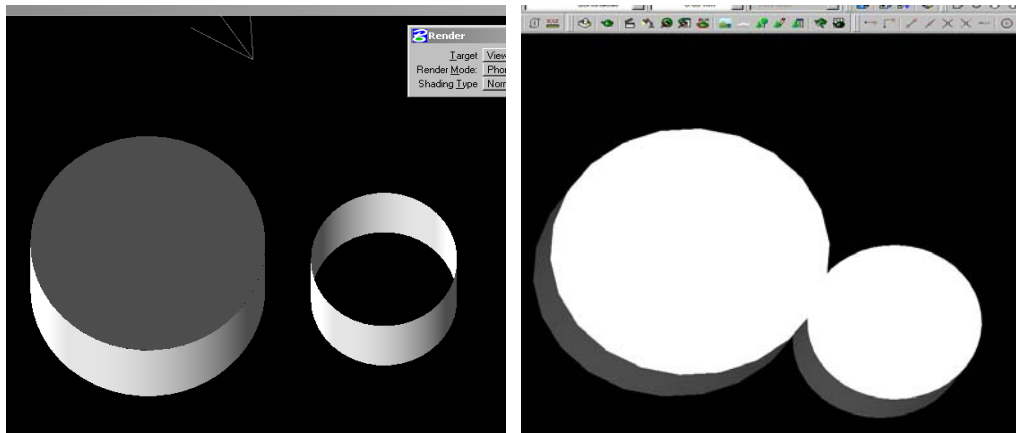

Fig 9: Cylinders (solid & surface) look the same when rendered in Arch. 3.3

- ❖ A total of three elements were drawing in MicroStation (cylinder, sphere and cone), when imported to Architectural Desktop 3.3, only two elements (sphere and cone) are presented. Also, wiremesh elements look different from original with fewer lines (again program's setting). As far as modifications ability concern, only moving shapes around is possible in Architectural Desktop 3.3.
- ❖ “circular filleted” element exposed the same smoothness problem as encountered earlier by circles and “chamfered corners” exported to “Architectural Desktop 3.3” did not respond which is due to initial receiving program setting, *see figure (10)*.

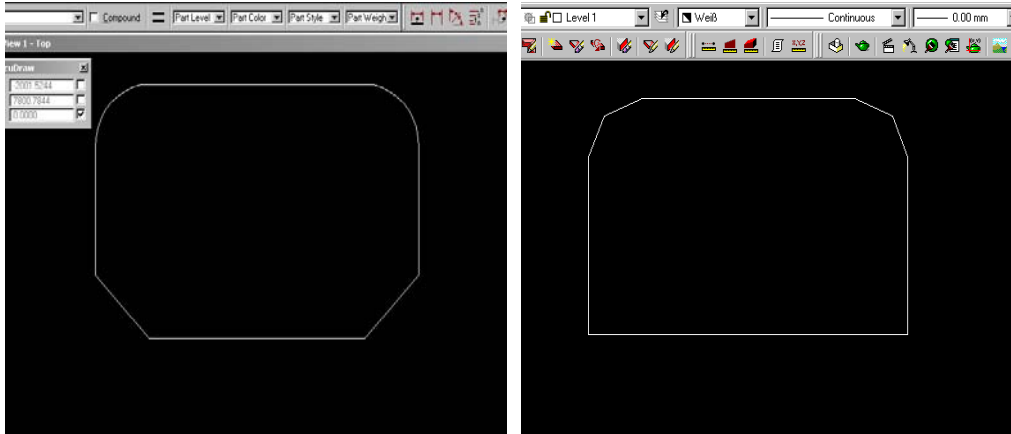

Fig 10: “circular filleted” and “chamfered corners” differ in Arch. 3.3

- ❖ “Solid slab” exported from “MicroStation” to “Architectural Desktop 3.3” allow for different modifications abilities. Once arrived at “Desktop”, the user can modify one point of the slab without having to move the whole slab where originally, modifying one point of the slab means enlarging or decreasing the size of the whole slab as seen in *figure (11)*. However, exported “surface slab” acts in the same manner as in original applications.

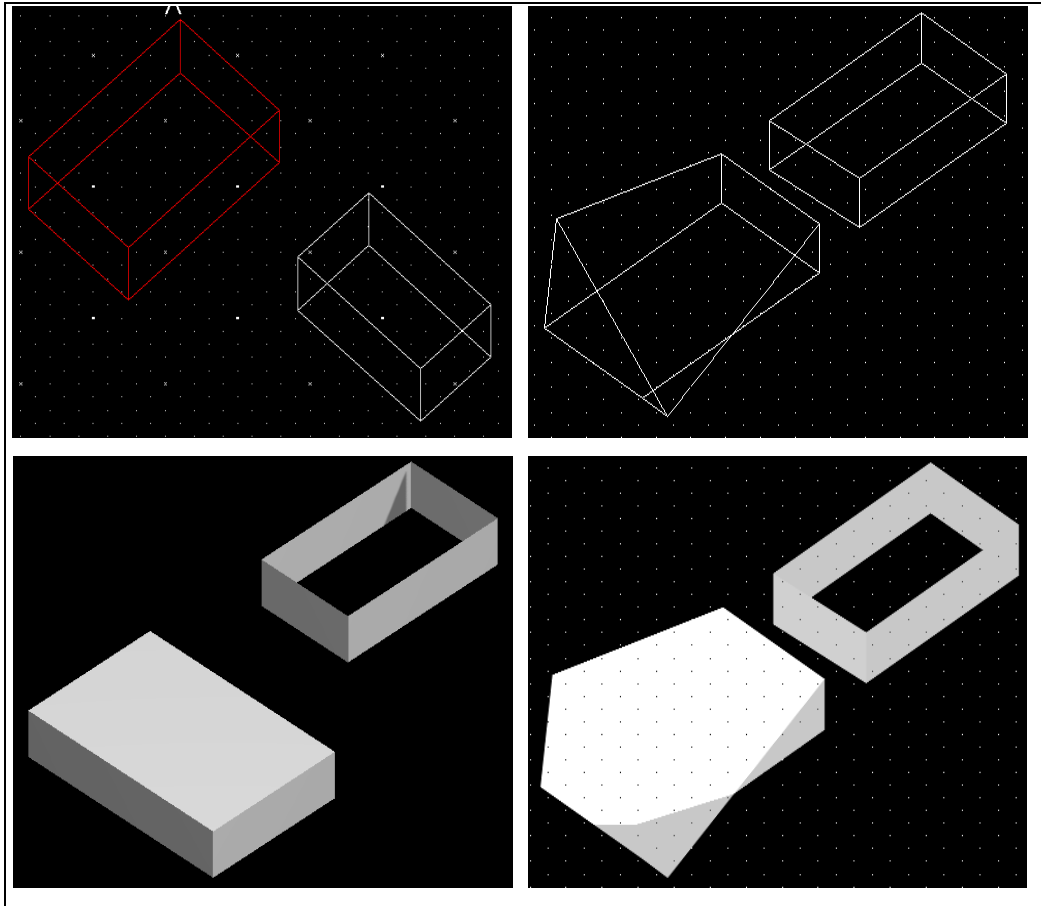

Fig 11: Solid slab behaves differently in Arch. 3.3

- ❖ Software initial settings seem to appear in many other occasions which cause some confusing during the sharing process. Example is the “sphere” which also poses its own appearance problems. It is represented differently as a 3D wiremesh object which is illustrated by *figure (12)*.

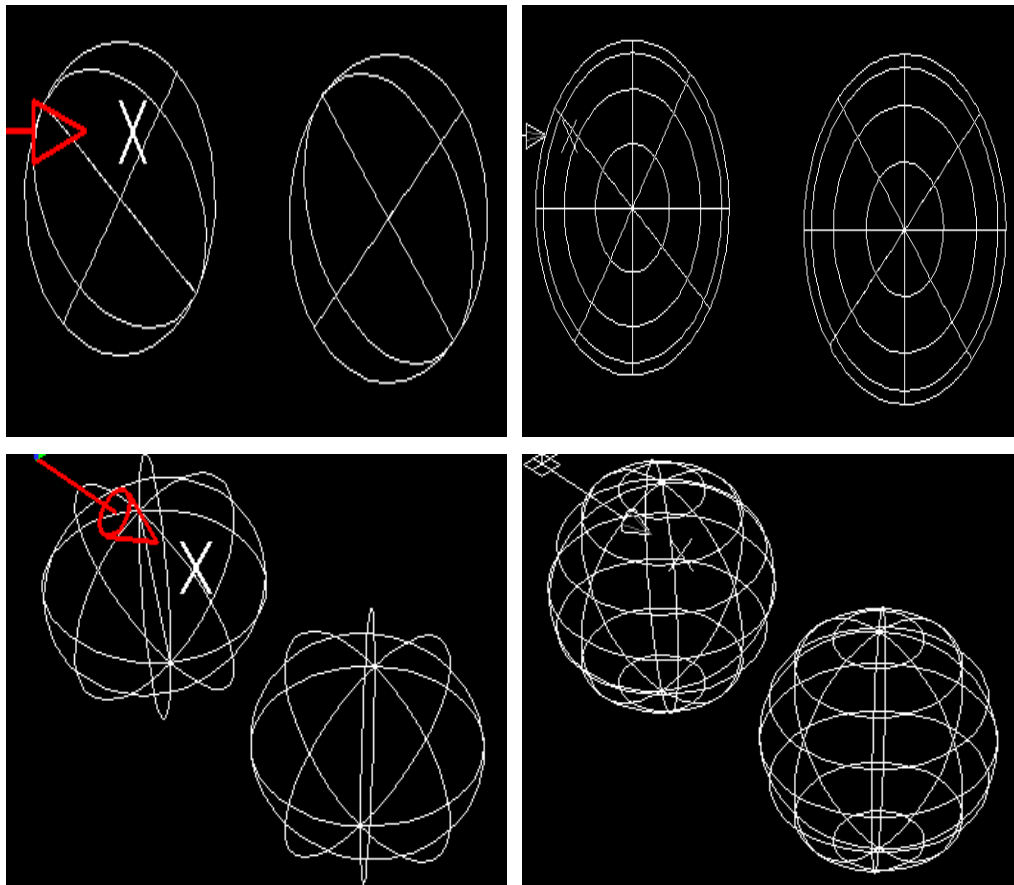

Fig 12: Shows sphere's different appearance in Arch. 3.3

- ❖ “Cones” drawing in “MicroStation” and exported to “Architectural Desktop 3.3” are also suffered from 3D wiremesh representation as direct results of initial software settings *figure (13)*.

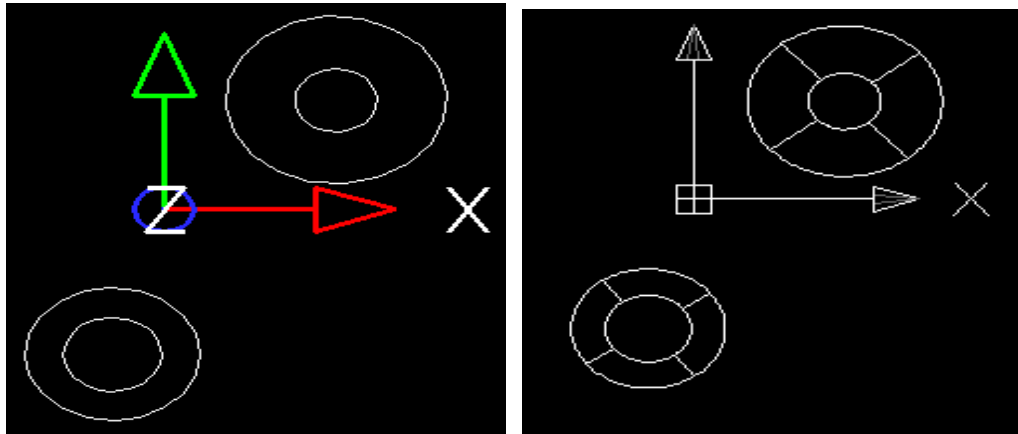

Fig 13: Arch. 3.3 represents “Cones” wiremesh differently

3.3.3 Exporting elements form Allplan 2004 to MicroStation V8

Once again, the issue of “license agreement” between “Allplan” and “MicroStation” arises. This means elements exported form “Nemetschek Allplan 2004” will be saved as “MicroStationV7” format. However, in this case, “MicroStationV8” works around this obstacle and recognizes the exportation process and poses two possible solutions: 1) Upgrade the file to V8 format or 2) open the file as read-only (keep as V7 format). Therefore, for the purpose of sharing data between the two applications, the first option is chosen.

Nemetschek Allplan	Elements names in German	Status of exported elements	Element identified as (in MS)
2D Elements			
Basic Tools	Basisfunktionen		
Line	Linie	Ok, exact measurements	Line
Construction Line	Konstruktionslinie	Ok	Construction line
	Polygonzug	Ok	Line
Point	Punkt	Ok	Shape
Rectangle	Rechteck	Ok, exact measurements	Individual lines
Circle	Kreis	Ok	Circle
General Circle	Kreis allgemein	Ok	Circle
	N-Eck	Ok, measurements not accurate	Individual lines
Ellipse	Ellipse	Ok	Arc
Spline	Spline	Not ok	Curve
Single point	Einzelpunkt	Ok with extra information	Shared Cell (lines & circles)
Free hand line	Freihandlinie	Ok	Complex chain, line
Hatching	Schraffur	Ok, association lost	Shape
Pattern	Muster	Ok	Shape
Extended construction	Erweiterte Konstruktion		
Symbol	Symbolpunkt	Not ok	Text
Spline with	Spline mit	Ok with appearance	Curve

connection	Anschlussrichtung	differences	
Chamfer	Fasen	Ok	Line
Axis	Achsraster	Ok, acts as individual elements	Line & text
Polar axis	Polarachsraster	Ok, but considered as separate elements	Line, Arc & text
Text	Text		
Horizontal Text	Text horizontal	Ok	Text
Vertical Text	Text vertikal	Ok	Text
Angled Text	Text unter Winkel	Ok	Text
Numbering Text	Text mit Nummerierung	Ok	Text
Bar code	Barcode	Ok	Shape & Text
Dimension Lines	Maßlinie		
Horizontal Dim.	Maßlinie horizontal	Ok. association lost	Dimension Line
Vertical Dim.	Maßlinie vertical	Ok association lost	Dimension Line
Angled line Dimension	Maßlinie im Winkel	Ok association lost	Dimension Line
Dimension lines in black form	Maßlinie in Blockform	Ok association lost	Dimension Line
Automatic dimensioning	Automatikbemaßung	Ok association lost & accuracy	Dimension Line
Curved dimension	Kurvenbemaßung	Ok	Line
Axis dimension	Achs bemaßung	Ok	Line & Text
Angle dimension	Winkelbemaßung	Ok	Arc & Text
3D Elements			
Roof and planes flyout			
Gable/Hip Roof	Dachhaut	Ok	Individual lines
Skylight	Dachflächenfenster	Ok	Shared cell (solids)
Architecture Components flyout			
Straight Wall	Gerade Wand	Ok	Solid
Rectangular Walls	Rechteckiger Wandzug	Ok	Solid
Curved Walls	Kreis-Wand	Ok	Solid
Circular Walls	Kreis-Wand um Mittelpunkt	Ok	Solid
Polygonal Walls Inscribed	N-Eck-Wand (halb)	Ok	Solid
Polygonal Walls Circumscribed	N-Eck-Wand (ganz)	Ok	Solid
Spline-Based Walls	Spline-Wand	Ok	Solid
Brace	Stütze	Ok, but different modifications	Solid

Slab	Decke	Ok, but different modifications	Solid (shapes)
Beam, suspender beam	Unterzug, Überzug	Ok, but modified differently	Solid (shapes)
Chimney	Schornstein	Ok, but different modifications	Solid (shapes)
Architecture			
Openings flyout			
Door	Tür	Ok	Shared cell (solids)
Window	Fenster	Ok	Shared cell (solids)
Corner Window	Eckfenster	Ok	Shared cell (solids)
	Öffnungsmodellierer	Ok	Shared cell (solids)
Rooms flyout			
Room	Raum	Ok	Solid (shapes)
Floor	Geschoss	Ok	Solid (shapes)
Stairs flyout			
Straight stairs	Gerade Treppe	Ok, but extra information	Solid (shapes)
Half coiled stairs	Halbgewendelte Treppe	Same as above	Solid (shapes)
Simple quarter stairs	Einfach viertelgewendelte treppe	Same as above	Solid (shapes)
Double quarter stairs	Zweifach viertelgewendelte treppe	Same as above	Solid (shapes)
Coiled stairs	Wendelte Treppe	Same as above	Solid (shapes)
U-Type Stair	Halbpodesttreppe	Same as above	Solid (shapes)
A four-valley landing stairs	Einviertalpodest Treppe	Same as above	Solid (shapes)
Two-four-valley landing stairs	Zweiviertalpodest Treppe	Same as above	Solid (shapes)

Table (3) Exporting elements from Nemetschek Allplan to MicroStation

According to table (2), it is noticeable that exportation from “Nemetschek Allplan” to “MicroStation V8” works more smoothly than the other way around. However, previously encountered issues and problems seem to occur in this case again. Elements association is a common issue occurring during sharing of information between “MicroStationV8” and “Allplan 2004”.

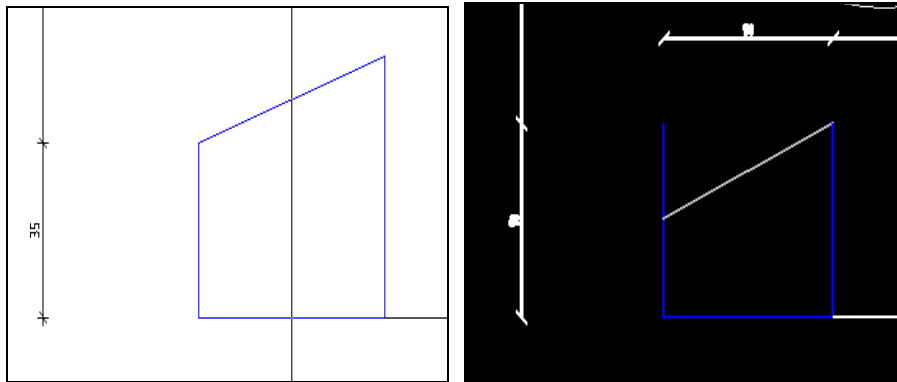

Fig 14: Illustrates lost of dimension association in Arch. 3.3

- ❖ Figure (14) illustrates the lost of dimension association by “Architectural Desktop” because the dimension did not react with the change in length, whereas on the left hand side (in Allplan), the dimension decreasing in accordance with the change in element’s length.
- ❖ “Polygonal Walls” looks ok after arriving at MicroStation, but lines measurements are not accurate and differ from original measurements.
- ❖ “Spline” shared between “Allplan 2004” to “MicroStationV8” appears different in smoothness and shape as seen *figure (15)*.

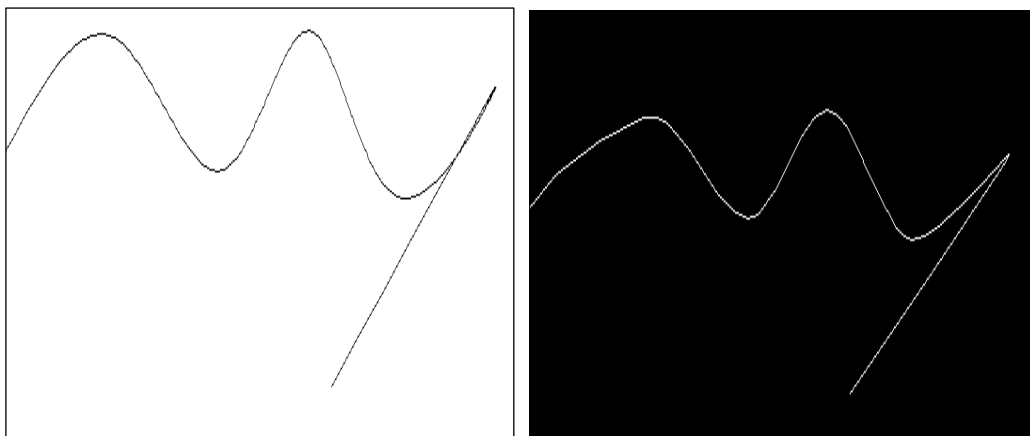

Fig 15: Illustrates the difference in Spline appearance

- ❖ All “single points” elements exported to MicroStation seem to have extra information (numbers) included which they are not present in original software (Allplan) as shown in *figure (16)*. These numbers drawing on top of each element on the left hand side figure are not part of the original elements and therefore consider as extra information that again may have to do with initial program settings.

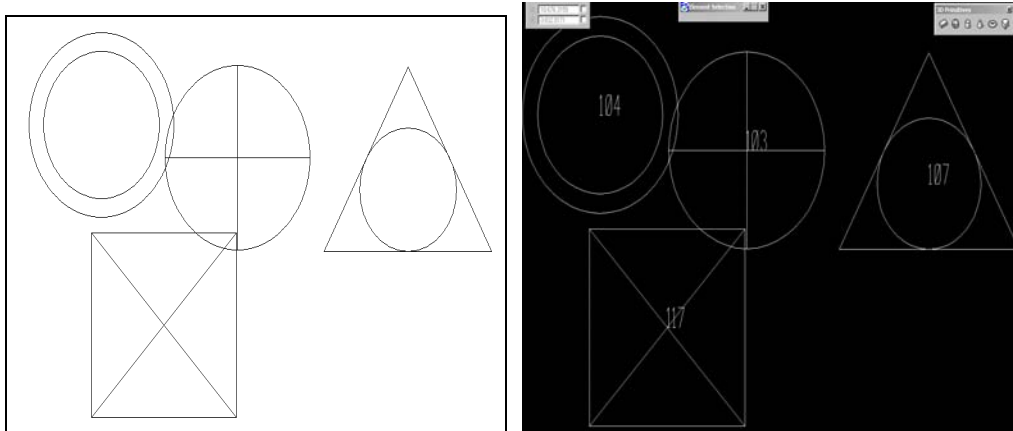

Fig 16: Shows extra information on top of each element in Ms

- ❖ A “freehand” line was exported to “MicroStation” without noticeable changes, however once modified, this “freehand” line acts as many segments and not one piece as in the original application.
- ❖ “Symbols” created in “Allplan 2004” are not possible to be shared with “MicroStationV8”, instead some numbers appears to represent these symbols as shown in *figure (17)*.

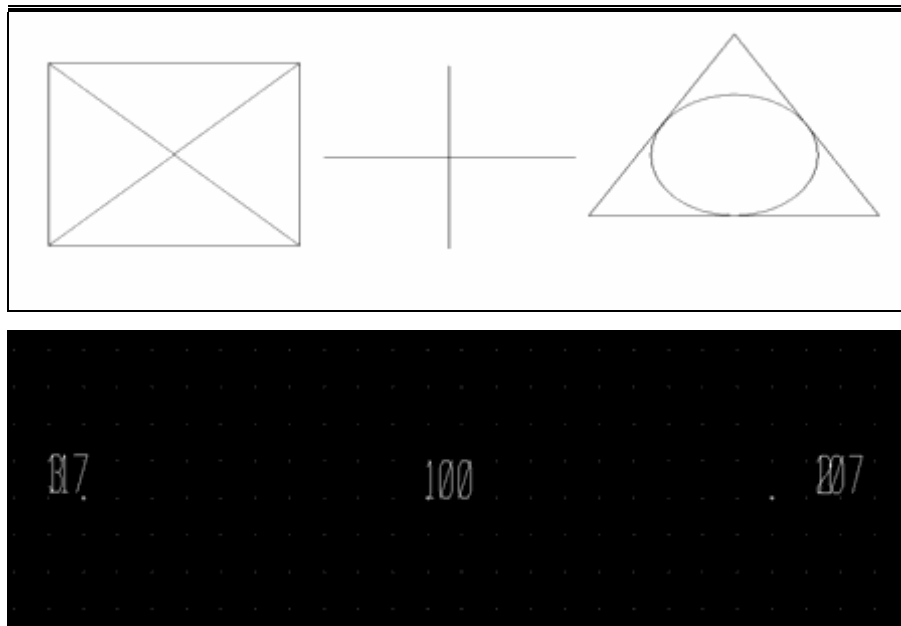

Fig 17: Symbols from Allplan are represented by numbers

- ❖ “Spline with connection” exported to “MicroStation” has different shape appearance as illustrated in *figure (18)*.

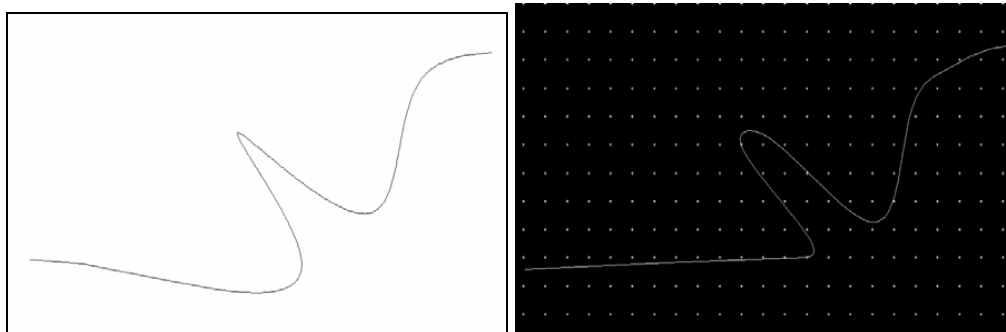

Fig 18: Spline with connection appeared differently in MicroStation

- ❖ “Barcode” seems to act like individual elements when exported to “MicroStation”, even though it is originally one element. Also, the overall appearance is different as shown in *figure (19)*.

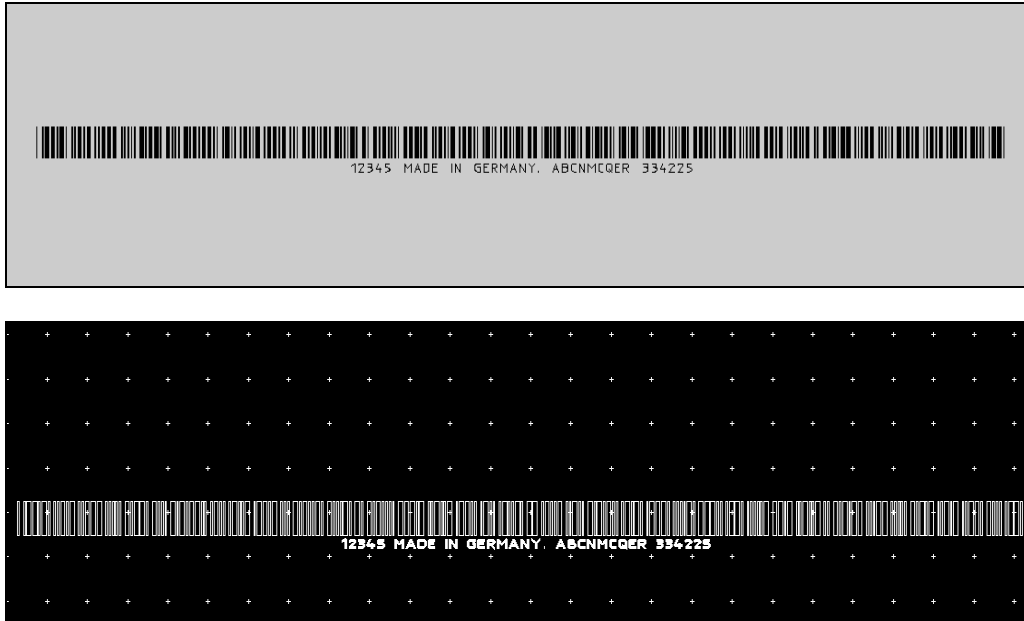

Fig 19: Barcode looks different in MicroStation

- ❖ “Automatic dimensioning” exported from “Allplan 2004” to “MicroStationV8” encountered two major problems, which are: losing dimensioning associations and measurements accuracy issue (round-off) as shown in *figure (20)*. The inaccuracy occurred because of different program’s round-off settings; however software must adapt to information coming from another programs and not changing or altering the imported data to allow for successful sharing process.

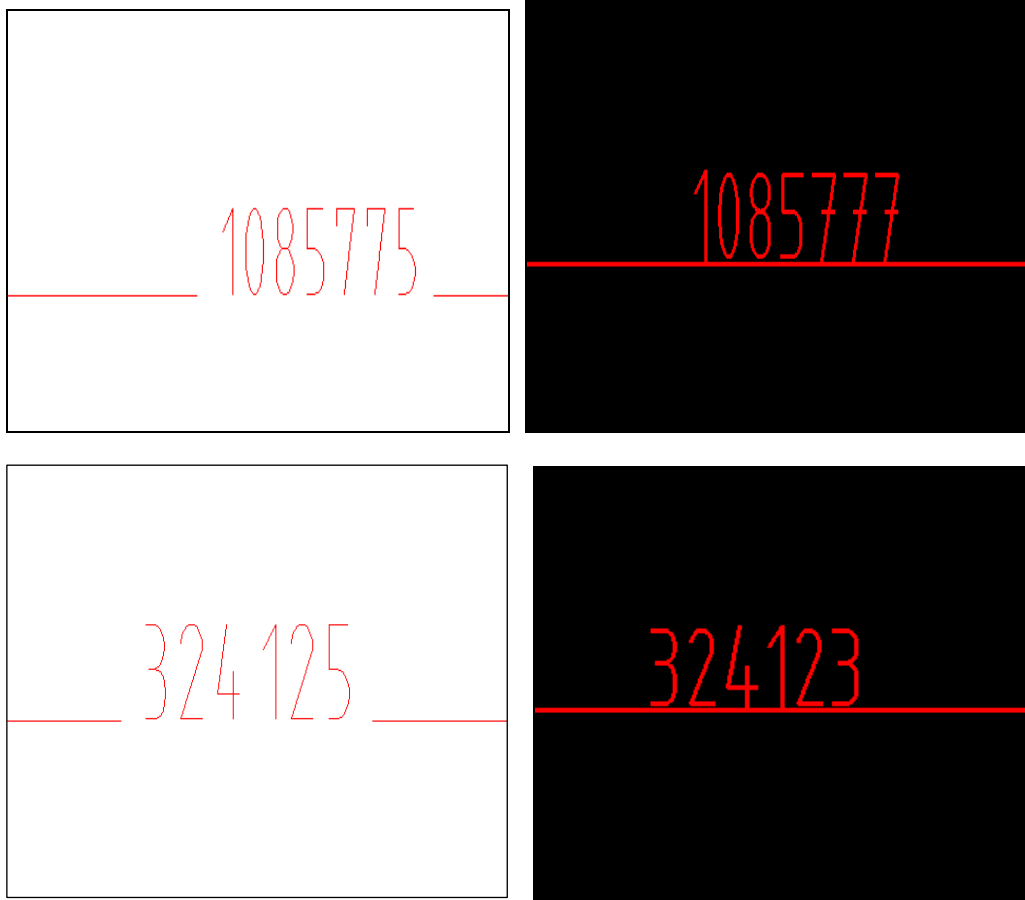

Fig 20: Automatic dimensioning association and accuracy problems

- ❖ “Stairs” exported to “MicroStation” showed extra information in rendering status as seen in *figure (21)*. Also, an important observation regarding wiremesh representation of all 3D elements exported from “Allplan” to “MicroStation” is the line thickness. “Allplan” uses 0.25 as the smallest thickness available, i.e. when a line with this thickness exported to “MicroStation”, it came up thicker with line thickness of “2” which is not the smallest in “MicroStation”.

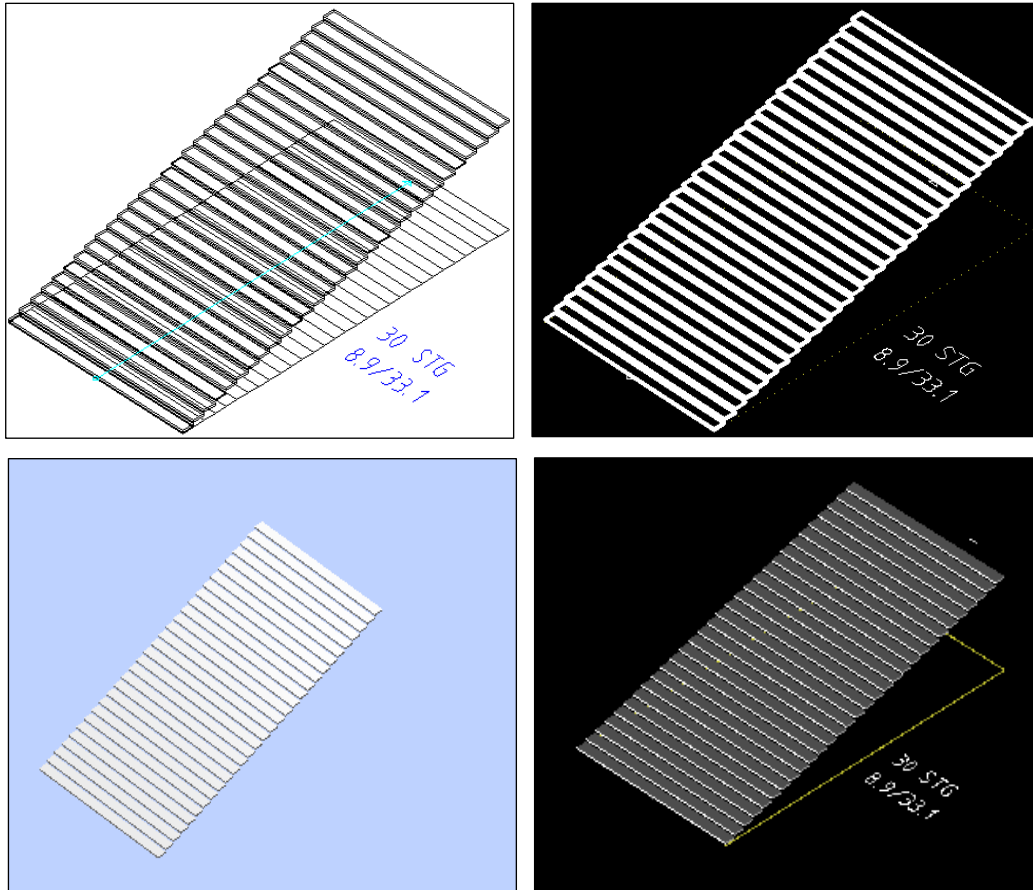

Fig 21: Stairs exported from Allplan to MS included hiding information

3.3.4 Exporting elements form Allplan 2004 to Architectural Desktop.3.3

Nemetschek Allplan	Elements names in German	Status of exported elements	Element identified as (in CAD)
2D Elements			
Basic Tools	Basisfunktionen		
Line	Linie	Ok	Line
Construction Line	Konstruktionslinie	Ok	Line
Polyline	Polygonzug	Ok	Polyline
Point	Punkt	Ok	Polyline
Rectangle	Rechteck	Ok	Line
Circle	Kreis	Ok	Circle
General Circle	Kreis allgemein	Ok	Arc
	N-Eck	Ok	Individual lines
Ellipse	Ellipse	Ok	Ellipse
Spline	Spline	Ok	Spline
Single point	Einzelpunkt	Ok	Block reference
Free hand line	Freihandlinie	Ok	Polyline
Hatching	Schraffur	Ok, but behaves differently & lost of association.	Hatch
Pattern	Muster	Ok	Hatch
Extended construction	Erweiterte Konstruktion		
Point Symbol	Symbolpunkt	Ok	Block Reference
Spline with connection	Spline mit Anschlussrichtung	Ok	Spline
Chamfer	Fasen	Ok	Line
Axis	Achsraster	Ok	Line & Text
Polar axis	Polarachsraster	Ok	Circle, Line & Text
Text	Text		
Horizontal Text	Text horizontal	Ok	Text
Vertical Text	Text vertikal	Ok	Text
Angled Text	Text unter Winkel	Ok	Text
Numbering Text	Text mit Nummerierung	Ok	Text
Bar code	Barcode	Ok	Hatching & Text
Dimension Lines	Maßlinie		
Horizontal Dim.	Maßlinie horizontal	Ok, association lost	Dimension
Vertical Dim.	Maßlinie vertikal	Ok, association lost	Dimension
Angled line Dimension	Maßlinie im Winkel	Ok, association lost	Dimension

Dimension lines in black form	Maßlinie in Blockform	Ok, association lost	Dimension
Automatic dimensioning	Automatikbemaßung	Ok	Dimension
Curved dimension	Kurvenbemaßung	Ok	Block Reference
Axis dimension	Achsbemaßung	Ok	Block Reference
Angle dimension	Winkelbemaßung	Ok	Block Reference & Text
3D Elements			
Roof and planes flyout			
Gable/Hip Roof	Dachhaut	Ok	Block Reference
Skylight	Dachflächenfenster	Ok	Block Reference
Architecture Components flyout			
Straight Wall	Gerade Wand	Ok	Solid
Rectangular Walls	Rechteckiger Wandzug	Ok	Solid
Curved Walls	Kreis-Wand	Ok	Solid
Circulated Wall around middle point	Kreis-Wand um Mittelpunkt	Ok	Block Reference
Polygonal Walls Inscribed	N-Eck-Wand (halb)	Ok	Solid
Polygonal Walls Circumscribed	N-Eck-Wand (ganz)	Ok	Solid
Spline-Based Walls	Spline-Wand	Ok	Solid
Brace	Stütze	Ok, but some difference at bottom	Solid
Slab	Decke	Ok	Solid
Beam, suspender beam	Unterzug, Überzug	Ok	Solid
Chimney	Schornstein	Ok	Block Reference
Architecture Openings flyout			
Door	Tür	Ok	Arc & line
Window	Fenster	Ok	Block Reference
Corner Window	Eckfenster	Ok	Block Reference
Rooms flyout			
Room	Raum	Ok, extra information	Solid & Text
Floor	Geschoss	Ok, extra information	Solid & Text
Stairs flyout			
Straight stairs	Gerade Treppe	Ok, but with extra information	Solid
Half coiled stairs	Halbgewendelte Treppe	Ok, but with extra information	Solid
Simply quarter stairs	Einfach viertelgewendelte	Ok, but with extra	Solid

	treppe	information	
Doubly quarter stairs	Zweifach viertelgewendelte treppe	Ok, but with extra information	Solid
Coiled stairs	Wendelte Treppe	Ok, but with extra information	Individual lines
U-Type Stair	Halbpodesttreppe	Ok, but with extra information	Solid
A four-valley landing stairs	Einviertalpodest Treppe	Ok, but with extra information	Solid
Two-four-valley landing stairs	Zweiviertalpodest Treppe	Ok, but with extra information	Solid
Stairs with arbitrary sketch	Treppe mit beliebigem Grundriss	Ok, but with extra information	Solid

Table (4) Exporting elements from Nemetschek Allplan to Arch.3.3

Table (4) illustrates the level of accuracy maintained during the sharing process between “Architectural Desktop 3.3” and “Nemetschek Allplan 2004” in term of measurements and identification of elements as well as exact coordination. However, some of the common exchanging problems encountered previously, such as hatching and dimensioning associations are also present in this case which are explained as follow:

- ❖ Hatched elements exported from “Allplan” to “Autodesk” behave totally differently in term of modifications, in addition to loosing original association.
- ❖ Although “wall unit” exported from “Allplan” to “Autodesk Architectural” has maintain its exact original measurements and rendered ok (*figure 22*), it is presented differently in “wiremesh” as seen in *figure (23)*.

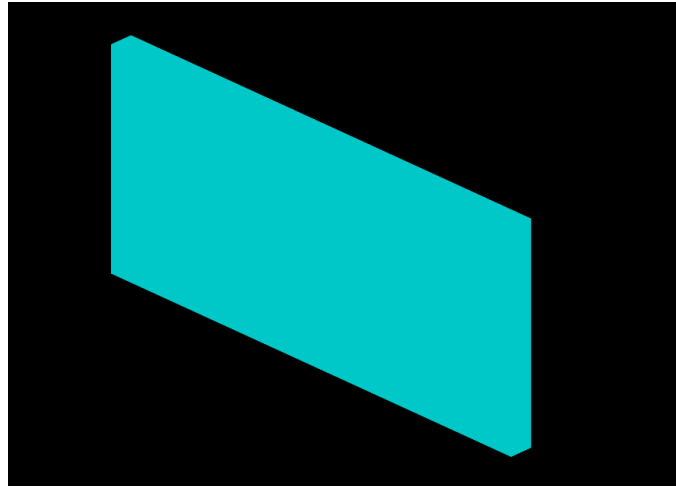

Fig 22: “Allplan” wall unit accepts “Arch. 3.3” rendering command

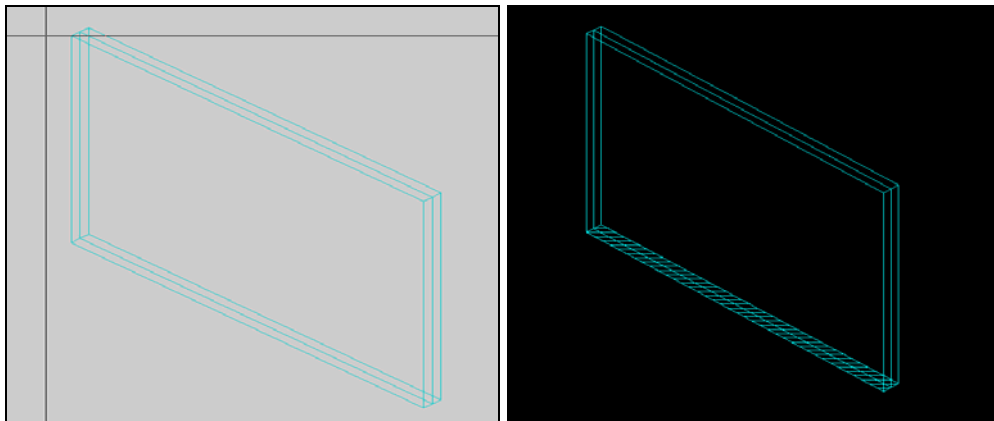

Fig 23: illustrates the difference in wall unit at bottom

- ❖ “Allplan Spline”, when exported to “Architectural Desktop 3.3” has the same characters but functions differently. In its source program the “Spline” works as one unit (*figure 24*); however this “Spline” (in Architectural Desktop 3.3) functions as individual segments and can be modified at each point, *figure (25)*.

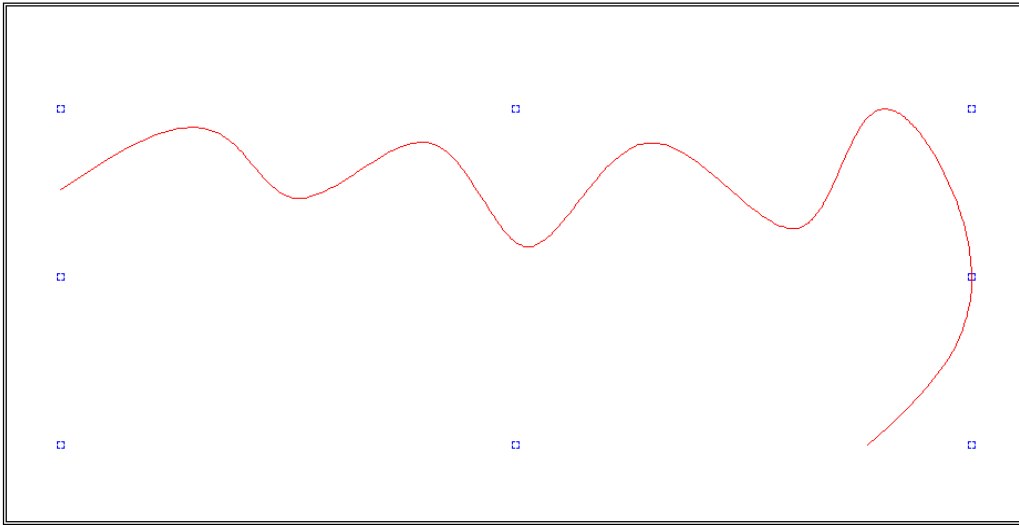

Fig 24: Nemetschek Allplan “Spline” works as one unit

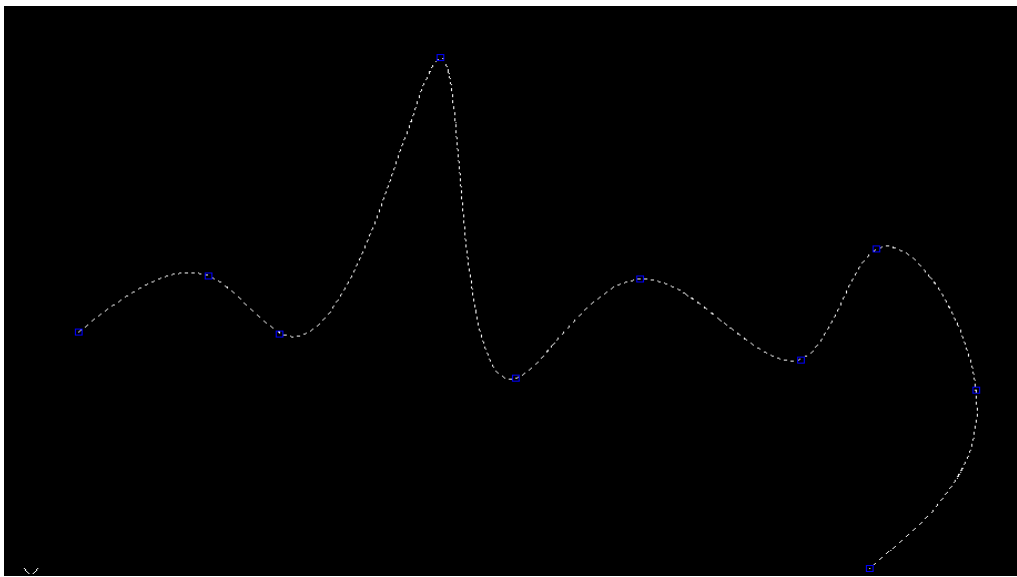

Fig 25: Arch. 3.3 “Spline” behaves as separate elements and modified differently

- ❖ Different presentation of “Braces” exported to “Architectural Desktop 3.3” is encountered during the sharing process which is similar to the previous case of “wall unit”, *see figure (26)*.

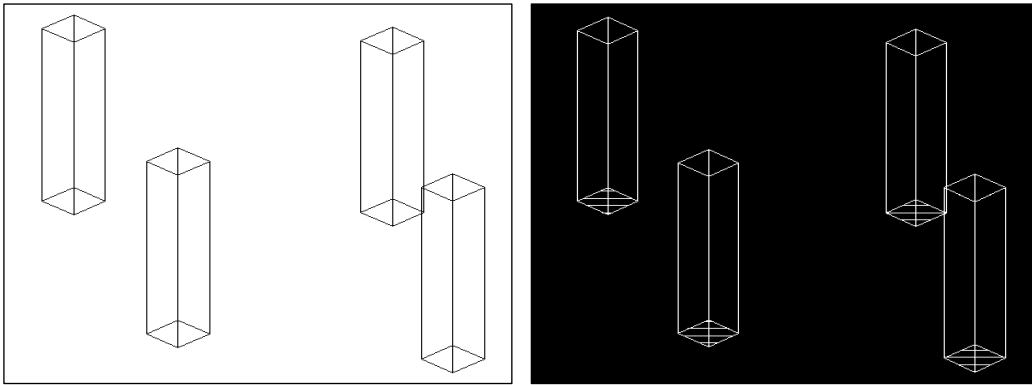

Fig 26: Shows the difference in braces at bottom

- ❖ “Room” exported from “Allplan” to “Desktop 3.3” preserve their original looks and features; however the room size seems to appear in all view by “Desktop” producing unnecessary information, figure (27).

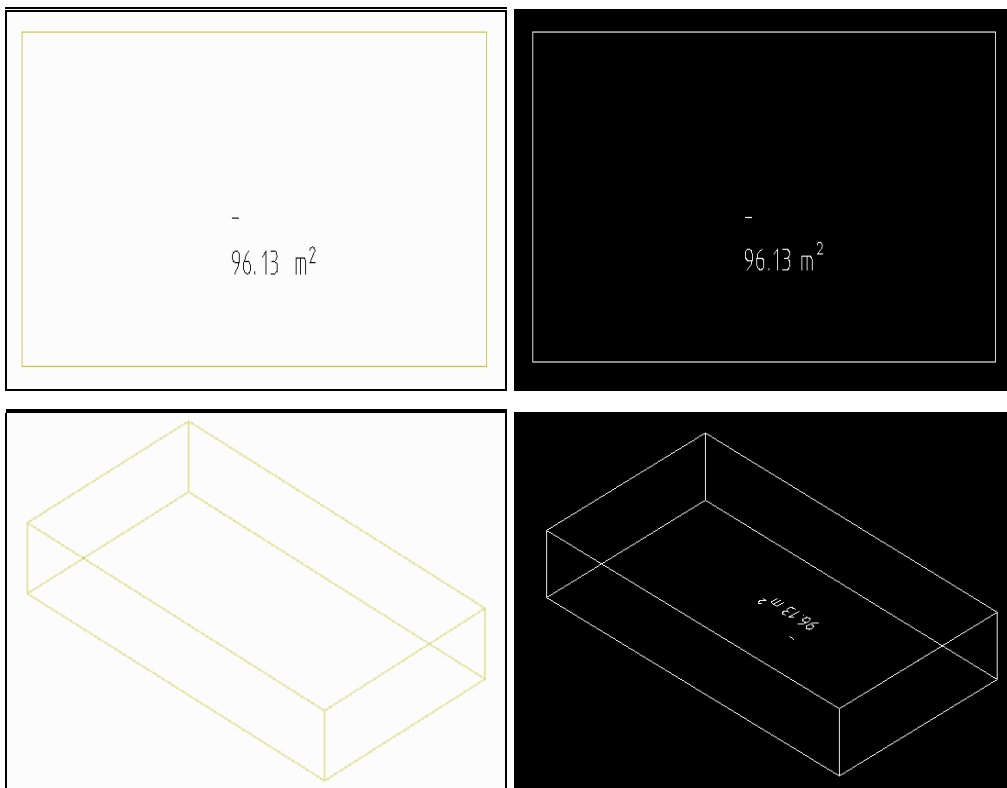

Fig 27: Extra information introduced in all views in “Arch.3.3”

- ❖ All type of “stairs” exported from “Allplan” to “Desktop 3.3” initiate the same issue as previous discussed by the preceding element (room) as well as some falls wiremesh presentation especially with the “coiled” (round) stairs and “U-type” stairs, as seen in *figure (28)*.

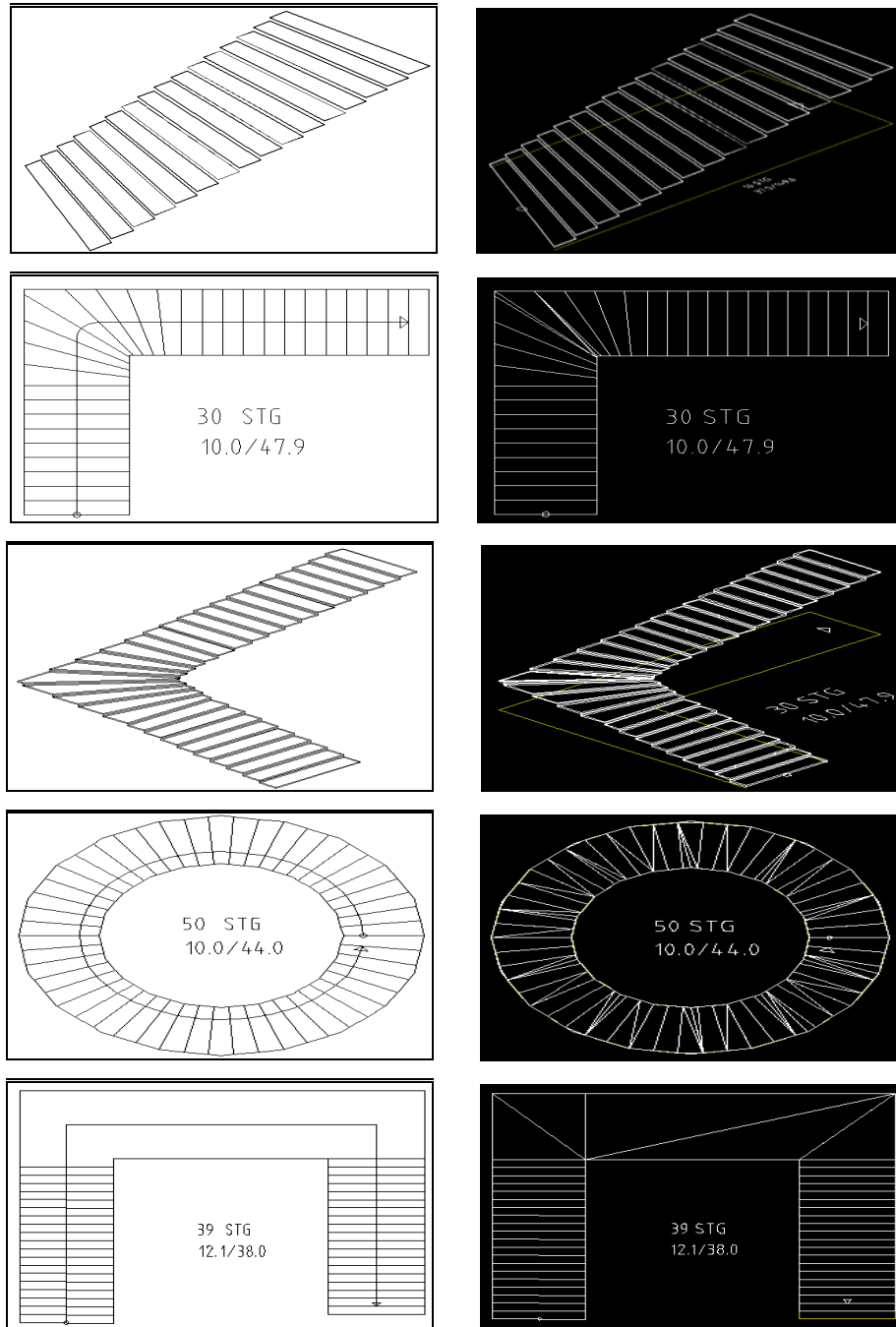

Fig 28: Extra data and falls “wiremesh” presentation of elements.

3.3.5 Exporting elements form Architectural Desktop 3.3 to MicroStation V8

Sharing design data between “Architectural Desktop 3.3” and “MicroStationV8” runs smoothly allow for better compatibility compared with the preceding situations which clearly shown by table (6). However, some viewing problems related to rendering and initial software settings need some attention as well as some other worth mentioning issues which are presented, explained in more details and illustrated by figures hereafter.

Architectural Desktop 3.3	Elements names in German	Status of exported elements	Element identified as (in MS)
2D Elements			
Line	Linie	Ok, exact measurements & coordinates.	Line
Construction line	Konstruktionslinie	Ok	Line
Multi-line	Multilinie	Ok	Multi-line
Polyline	Polylinie	Ok, but without thickness.	Line
Polygon	Polygon	Ok	Shape
Rectangle	Reckteck	Ok	Shape
Arc	Bogen	Ok	Arc
Circle	Kreis	Ok	Ellipse
Spline	Spline	Ok	Interpolation curve
Ellipse	Ellipse	Ok	Ellipse
Ellipse Arc	Ellipse Bogen		Arc
Hatching (with & without association)	Schraffur	Ok	Hatching
Cross hatching (with & without association)		Ok	Hatching
Text	Text	Ok	Text
Dimensions (Vertical & Horiz)		Ok	Dimension lines
3D Elements			
3D face	3D-Fläche	Ok	Smart solid
Cylinder	Zylinder	Ok	Smart solid
Cuboids	Quader	Ok	Smart solid
Wedge	Keil	Ok	Smart solid
Cone	Kegel	Ok	Smart solid
Sphere	Kugel	Ok	Smart solid
Ring	Torus	Ok	Smart solid

Table (5) Exporting elements from Arch.3.3 to MicroStation V8

- ❖ Although “MicroStation” has recognized hatching elements imported from “Architectural Desktop 3.3” with exact names as stated there (i.e. hatching ANS 137), a major concern was posed by “sphere”. Once in “MicroStation” this “sphere” though looked similar, it did not rendered as shown by figure (29).

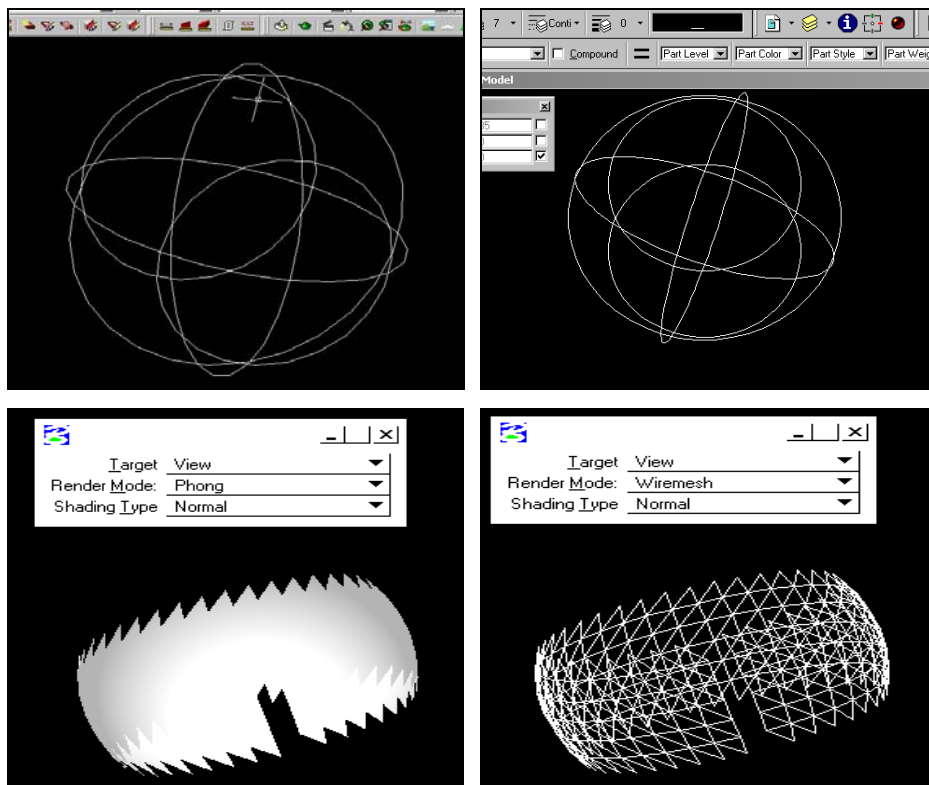

Fig 29: Sphere imported from Arch.3.3 to MS in different stages

- ❖ The previous “wiremesh” viewing problems exist also when exporting different “3D shape” to “MicroStation”. These shapes are view differently as MicroStation 3D wiremesh objects and did not allow for rendering (figure 30).

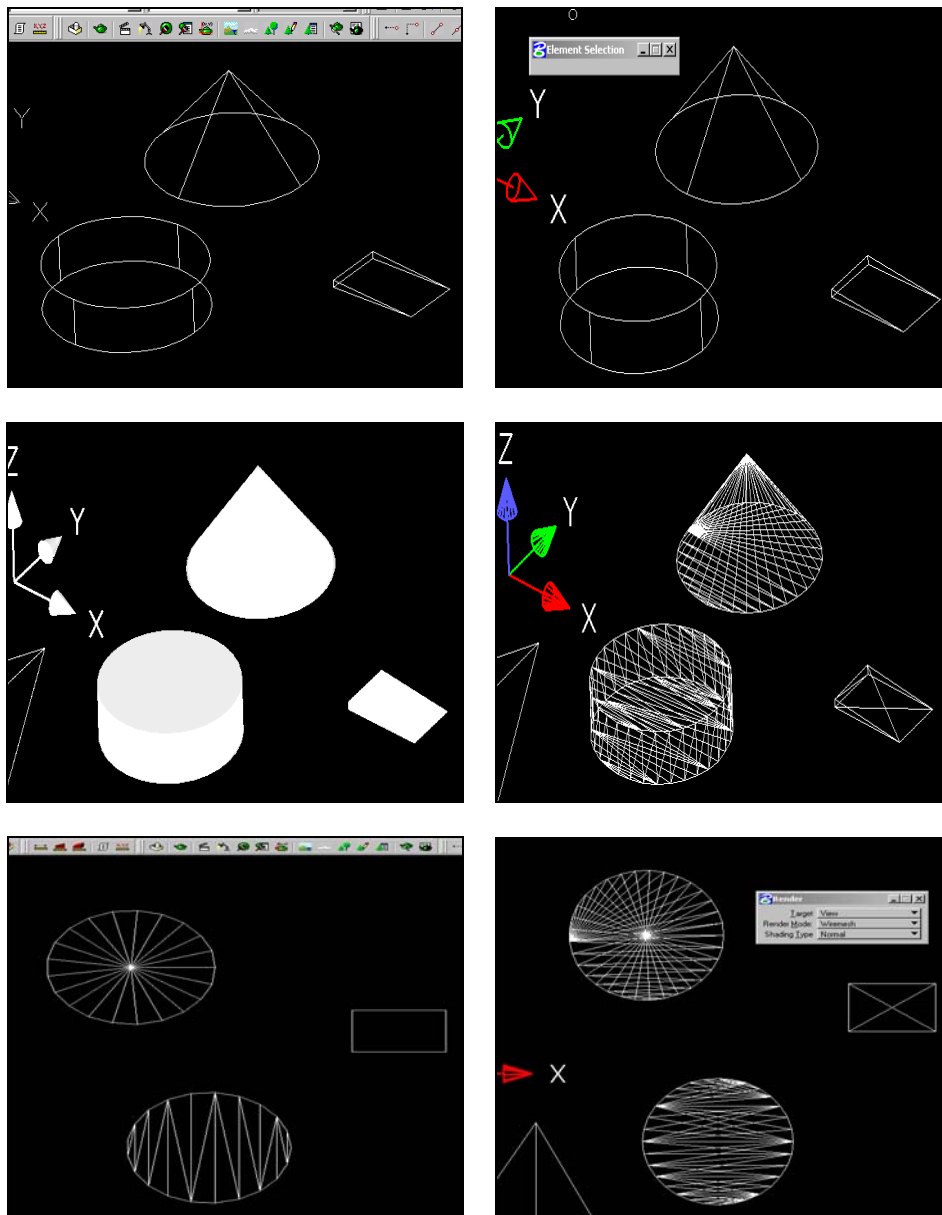

Fig 30: 3D shapes falsely represented and did not render in MicroStation.

3.3.6 Exporting elements form Arch. 3.3 to Nemetschek Allplan 2004

Although, “Nemetschek Allplan 2004” seems to recognize and identify elements imported form “Architectural Desktop 3.3” in a good manner, there is always the issue of loosing dimensioning association as well as modification ability of some elements such as “Spline” and “Ellipse”. Also, dimensioning text modification proofs to be an issue as shown by table (6) and associated attached figures.

Architectural Desktop 3.3	Elements names in German	Status of exported elements	Element identified as (in Nemetschek Allplan)
2D Elements			
Line	Linie	Ok	3D Line
Construction line	Konstruktionslinie	Ok	3D line
Multi-line	Multilinie	Ok	3D Line
Polyline	Polylinie	Ok	3D Line
Polygon	Polygon	Ok	3D Line
Rectangle	Rechteck	Ok	3D Line
Arc	Bogen	Ok, modification is different	3D Line
Circle	Kreis	Ok	Circle
Spline	Spline	Ok	Spline
Ellipse	Ellipse	Ok	Ellipse
Ellipse Arc	Ellipse Bogen	Ok	3D Line
Hatching	Schraffur	Not Ok, association lost	Hatching
Text	Text	Ok	Text
Dimensions (Vertical & Horiz)		Ok	Dimensions lines
3D Elements			
Solid	Solid	Ok	Individual 3D lines
3D face	3D-Fläche	Ok	Individual 3D lines
Cylinder (solid)	Zylinder	Not possible	
Cuboids	Quader	Ok	Individual 3D lines
Wedge(surface)	Keil (Flächen)	Ok	Individual 3D lines
Cone	Kegel	Ok	Individual 3D lines
Sphere (surface)	Kugel (Flächen)	Ok, no rendering	Individual 3D lines
Ring	Torus	Ok	Individual 3D lines

Table (6) Exporting elements form Arch. 3.3 to Nemetschek Allplan

First of all, one obvious advantage of importing elements from “Architectural Desktop” to “Nemetschek Allplan” is accuracy. In this case, accuracy is not an issue, because elements shared between the two programs maintain their same exact measurements and coordinates. However, several important issues arise during sharing which are explained as follow:

- ❖ Modification abilities of dimensions: Unlike the original program, dimension measurements (text) exported to “Allplan” is attached to the dimension line which makes it not possible to modify that text (measurement) alone, whereas this was possible originally in “Architectural Desktop 3.3”.
- ❖ “Hatching” first appearance: Hatching exported to “Allplan” seems to have more lines and closer to each other compared to its status before exportation (in Architectural Desktop 3.3) *see figure (31)*.

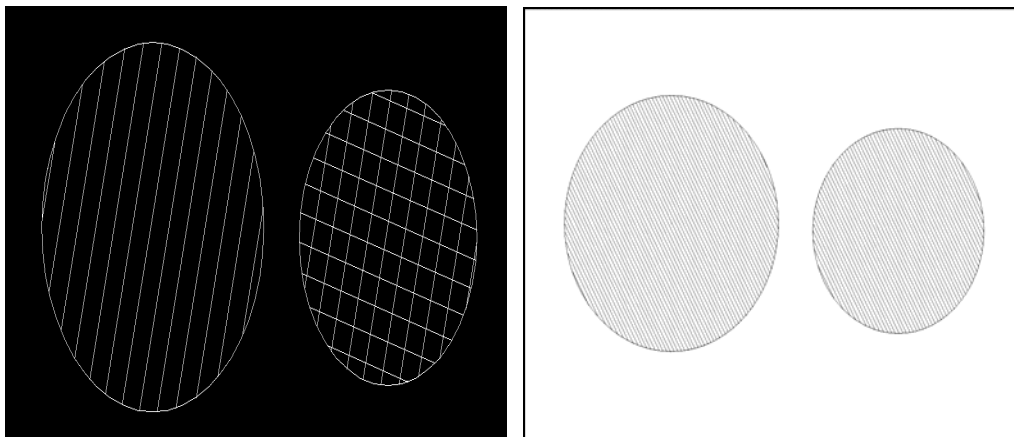

Fig 31: Hatching imported from Arch.3.3 to Allplan look different.

- ❖ “Cross-hatching” seems to cause more problems once arrived in Allplan; only straight lines appeared instead of cross lines

originally created in Architectural. Also, lost of dimensioning association acknowledge in both hatching, *figure (32)*.

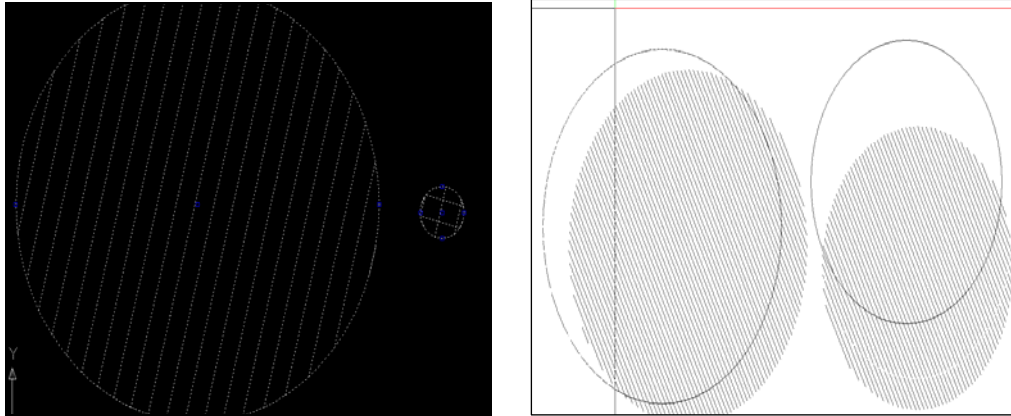

Fig 32: Illustrates the loss of hatching association.

- ❖ The “Sphere” animates like original but cannot be modified in the same way.
- ❖ The “Architectural Desktop 3.3 Spline” when imported to “Nemetschek Allplan” works as one unit, and allows for different modifications abilities as shown in figure (33).

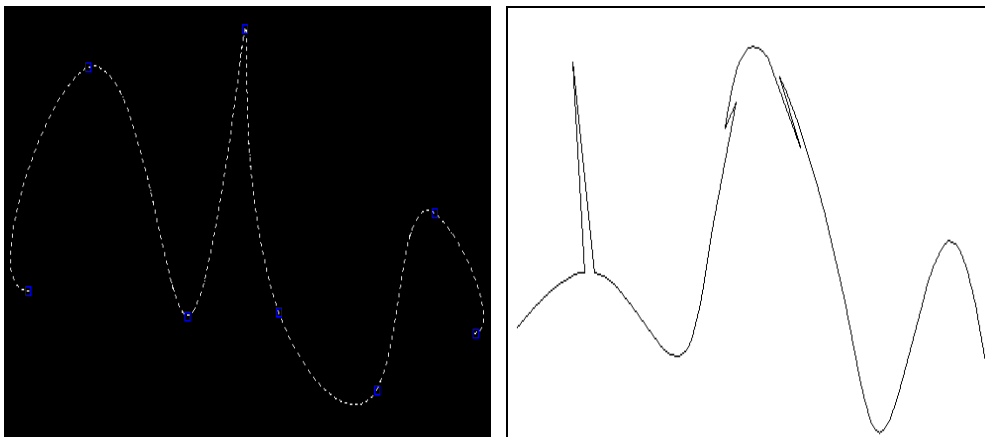

Fig 33: Arch. 3.3 Spline is modified differently in Nemetschek Allplan

- ❖ Also the same modification ability issue occurred with “Ellipse” imported from “Architectural Desktop 3.3” to “Allplan”.
- ❖ Importing 3D elements to “Allplan” is only possible if they are surface element, 3D solid elements are not possible to be imported from “Architectural Desktop 3.3” to “Allplan”. In addition, surface elements cannot be rendered in “Allplan” as shown in *figure (34)*.

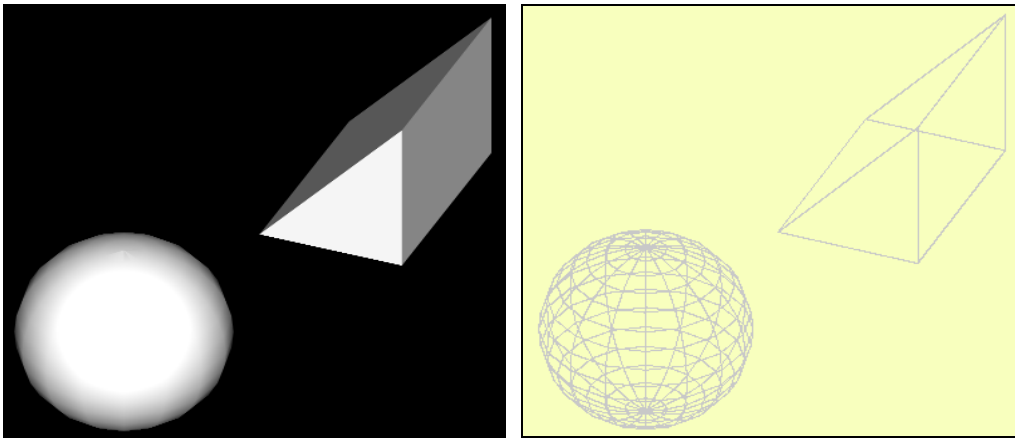

Fig 34: “Architectural Desktop” 3D elements cannot be rendered by “Allplan”

3.4 Conclusion and discussion

This chapter has examined and investigated data exchange ability between three proposed CAD applications which are available at Berlin University of Technology (TU Berlin) which are: 1) Bentley's MicroStation V8 (Architecture); 2) Nemetschek Allplan 2004; and 3) Autodesk Architectural Desktop 3.3 (Deutsch version). The aim was to explore these proposed CAD applications currently used by the AEC industry and examine their compatibility and interoperability. The emphasis was to examine each of the proposed applications ability to share design data with the others, by means of exporting and importing single elements between them.

Optimistically, observation throughout this chapter indicates that there is a sense of communication between these applications, especially how fast and easy data were delivered from one application to another without the use of third-party tools. Most importantly, vendors and software producing bodies are considering compatibility and allowing for data exchange abilities with other related products which clearly illustrated throughout this chapter.

However, although in many occasions the exchanged elements have passed smoothly and function exactly in the same way after sharing, some elements pose serious problems that hinder the sharing ability and full compatibility between applications which are used by the same people for the same purposes in the same industry. These problems which occurred during this process and their related sequences are explained as follow:-

- ***Loosing of elements associations***: the most repeated problem found in this research is losing associations in both hatching and

dimensioning. Generally, most types of dimensions and hatches exchanged between proposed applications have lost their association abilities as illustrated throughout this chapter. This could be very damaging to the accuracy and quality of design and consequently required manual editing of certain dimensions.

- **3D wiremesh representation:** this is a major issue which occurred in many occasions when exchanging 3D objects. Although due to initial software settings and could be solved easily, the user should be made aware of this or proposed software should be able to adapt to other software conditions.
- **Element modification abilities:** some elements once shared with other software, allow for a little or no modification at all.
- **Elements identifications:** how element being identified by other software is also an issue. It is well noticeable throughout this process and clearly shown in associated tables that many elements when exported to another program were falsely identified by the receiving application which means losing original property of elements.

This process has examined exchanging data between proposed CAD applications using single elements and not a complete file to pin point exact possible problems. Yet in practice, a complete design file would be transformed to another application in which some problems could not be easily identified. In addition, the AEC industry consists of several key players who generate large amounts of data that need to be shared among project's team members (architects, engineers, contractors, etc.) during its lifecycle. To give an example, the National Institute of Standards and Technology (NIST) in 2004 estimated \$15.6 billion per year is the cost of lack of interoperability in the U.S. capital

facilities market- including commercial, institutional and industrial-facilities [1].

With the widespread of CAD tools among companies and educational institutes, in addition to companies and firms going global, it is vital to acknowledge these problems and communication obstacles early prior to marketing in order to avoid damaging the already fragmented industry. Thus, these obstacles and hindrances should be considered in any future development by both vendors and industry practitioners. Also, the AEC industry should work closely with software inventors to lay down their requirements and expectations in order to gain maximum advantages of digitized era.

Finally, the investigations process throughout this chapter proves that unless standardizations of AEC industry software applications become part of future developments by both vendors and the AEC industry as a whole, this technology is limited and cannot be employed to its fullness. However, education institutions and industry are making efforts in this direction and improvements can already be noticed. Hence, this process took place from the period of October 2004 until May 2005, and softwares are usually developing and updating fast. So, helpfully these issues are already addressed in the newer versions.

4 VIRTUAL CITY EXAMPLE (VRCE)

4.1 Introduction

From the beginning of urban planning, designers, decision-makers and the general public have searched for innovative methods to visualize the built environment prior to actual construction. This includes colored maps and site plans, cardboard models and rich architectural renderings. Yet, these methods failed to be a complete, effective technique to visualize the past, present and future of a “place” to the vast array of bodies involved in the planning process.

Recently, the affordability and decrease cost of real time virtual reality both software and hardware, has made this technology more accessible and encouraged urban planners to adopt it as a tool of visualization. Mainly, due to large memory, processing and graphics power of today’s hardware which makes modeling and visualizing of large-area cities on computers feasible [84].

Thereby, virtual cities (sometimes called digital cities) emerged into cyberspace which, are computer based models that have enough of the qualities of real cities to give the user a real sense of being in an urban place. A virtual city can also be composed of a road network that provides the basic structure of the urban area and a large number of buildings that are arranged in blocks [3].

Consequently, introducing VR technology throughout the urban planning process enables users to navigate a virtual world safely and experience the environment as it currently exists, how it could have existed or as it might look in the future. Along the way, the user can also experiment with different alternative such as replacing existing

buildings with new developments and trees and foliage can be changed to see the impact. In addition, this technology allows users to query the available database to view information on buildings or places with the simulation [6&7]. Also, the real estate sector can benefit from virtually exploring a city by visualizing houses and objects within a 3D terrain and support the corresponding marketing and management activities. Simultaneously, the tourism sector is also to benefit from this technology by promoting their region and service on the internet, with links to further information such as hiking, ski and tourism areas as well as hotel and restaurant locations.

There are currently thousands of Cities on the World-Wide Web (WWW). New towns and cities are emerging in cyberspace, constructed with digital bricks and mortar, which are being called virtual cities, digital cities or cyber-cities. They are used for different purposes such as shopping, relaxing and meeting friends. Because cities layout is familiar aspect to most people, they are being used as an interface symbol to information and services on the WWW [4].

Among the groups who are to benefit from virtual cities are:- those interested in learning about the city in a fairly immediate way such as tourists; and those with a commercial interests which include business of all kinds; as well as professionals dealing with the city itself such as architects, planners and engineers [5].

An example is the 3D development of the old town of Edinburgh which is now well developed and integrated into the city planning process. Nowadays, to obtain planning permission in this town, a CAD model of the proposed development in the appropriate format must be submitted to be dropped into the virtual landscape. Also, the University of Bath has developed a 3D computer model of Bath which is been used by city planners to test visual impact of a number of proposed

developments in the city. In Berlin, the urban development and architecture unit of ART+COM has created the CyberCity Berlin and the Planwerk (a 3D masterplan of the city) using new media in town planning resulting from previous research on communication in city planning [6 & 7].



Fig 35: Examples of Virtual Cities on the WWW

Sources:

a: <http://www.skyscrapercity.com/showthread.php?t=307963> b: <http://bdcampbell.net/cities/Viewing.html>

c: <http://www.vision.ee.ethz.ch/~pmueller/wiki/CityEngine/PaperCities>

e: http://www.focus.de/digital/internet/bildergalerie_did_14477.html

f: <http://www.stadtentwicklung.berlin.de/planen/stadtmodelle/>

4.2 Objective

Due to an agreement between Berlin University of Technology (TUB) and Building and Housing Research Center (BHRC) in Iran to enlarge and broaden their cooperation and establish collaboration on further academic and research related development activities. TUB is now involving and working cooperatively with BHRC to plan and develop several projects in different chosen locations in Iran. One of these projects is the planning and development of Hashtgerd New Town which is the largest of the thirty currently planned Iranian New Towns.

Considering the availability and accessibility of data through this agreement, Hashtgerd New Town 2D plans will be used to develop a virtual city example (VRCE) to navigate and explore the town virtually. Mainly to explore and visualize the VREC, using virtual reality tools and methods now available for planners and decision-makers of the AEC industry. However, the VRCE will benefit from available 2D plan of the proposed 35 hectare project and a 2D image of the rest of Hashtgerd New Town to develop the complete 2D plan of the town. Then some proposed 3D models will be created and placed on top of the 2D plan to mock up Hashtgerd New Town in a virtual environment. The developed VRCE will consist of imaginary models and some actual proposed buildings models which will be dropped in the VRCE to experiment with different visualization tools and techniques.

4.3 Developing VRCE 2D plan

At the start of this exercise only a small section of the 35 hectare of Hashtgerd New Town 2D plan (figure 36) was available and usable. However, the VRCE project is to imitate the complete Hashtgerd New Town. Consequently, a photo image of Hashtgerd Newtown (figure 38) is utilized to create a full 2D plan of the area.

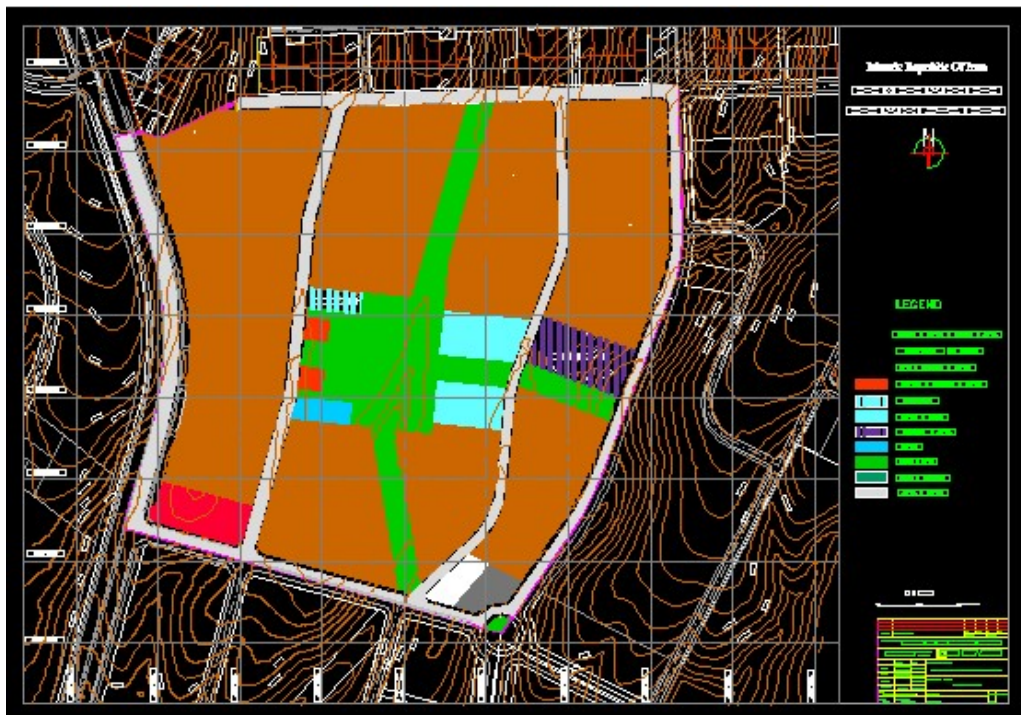

Fig 36: A small section of 2D plan of Hashtgerd Newtown

Starting with the 2D CAD file section which contains details and information that are not essential for this exercise such as contour lines, density, land usage, etc. and therefore had to be omitted from the plan. The 2D plan was exported to Bentley's MicroStation software to perform cleaning and eliminating the unnecessary data which result in the plan shown in figure (37).

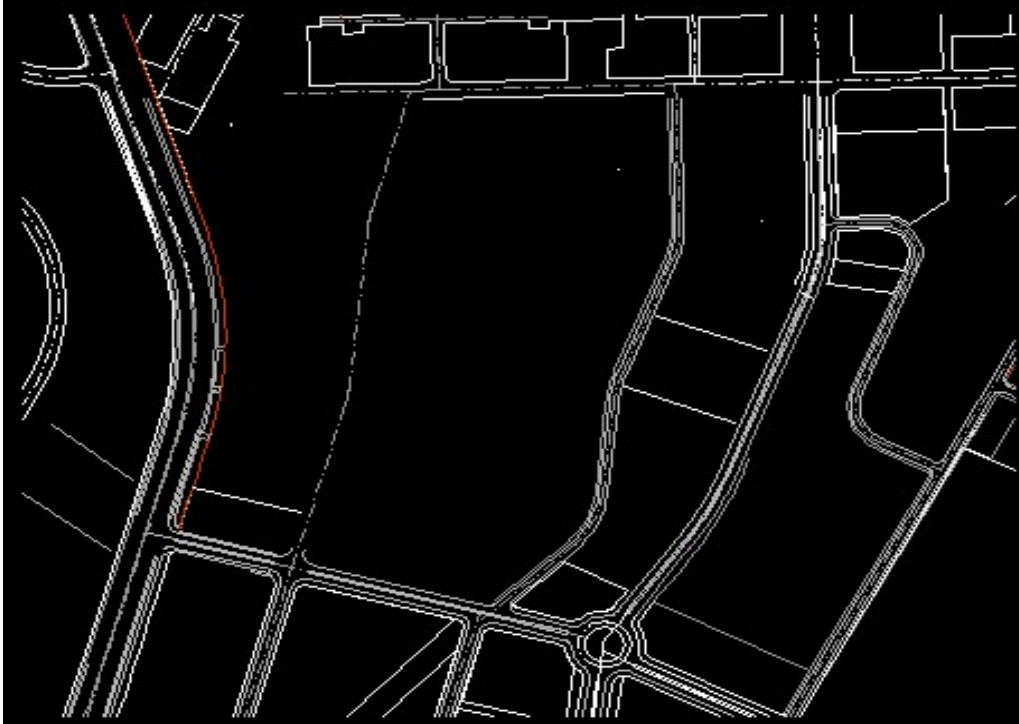

Fig 37: 2D section of Hashtgerd after eliminating extra information

To develop the rest of Hashtgerd New Town 2D plan, the photo image (figure 38) was used to imitate the town and was connected with the existing CAD section as close as possible. The final 2D plan of Hashtgerd is shown in figure (39) which is developed using Bentley's MicroStation and will be used next in developing the VR city. However, at this stage a 2D CAD plan of Hashtgerd (fig. 40) has being obtained from the designer and can be used hereafter.



Fig 38: A photo image of Hashtgerd Newtown



Fig 39: the full developed 2D plan of the VRCE

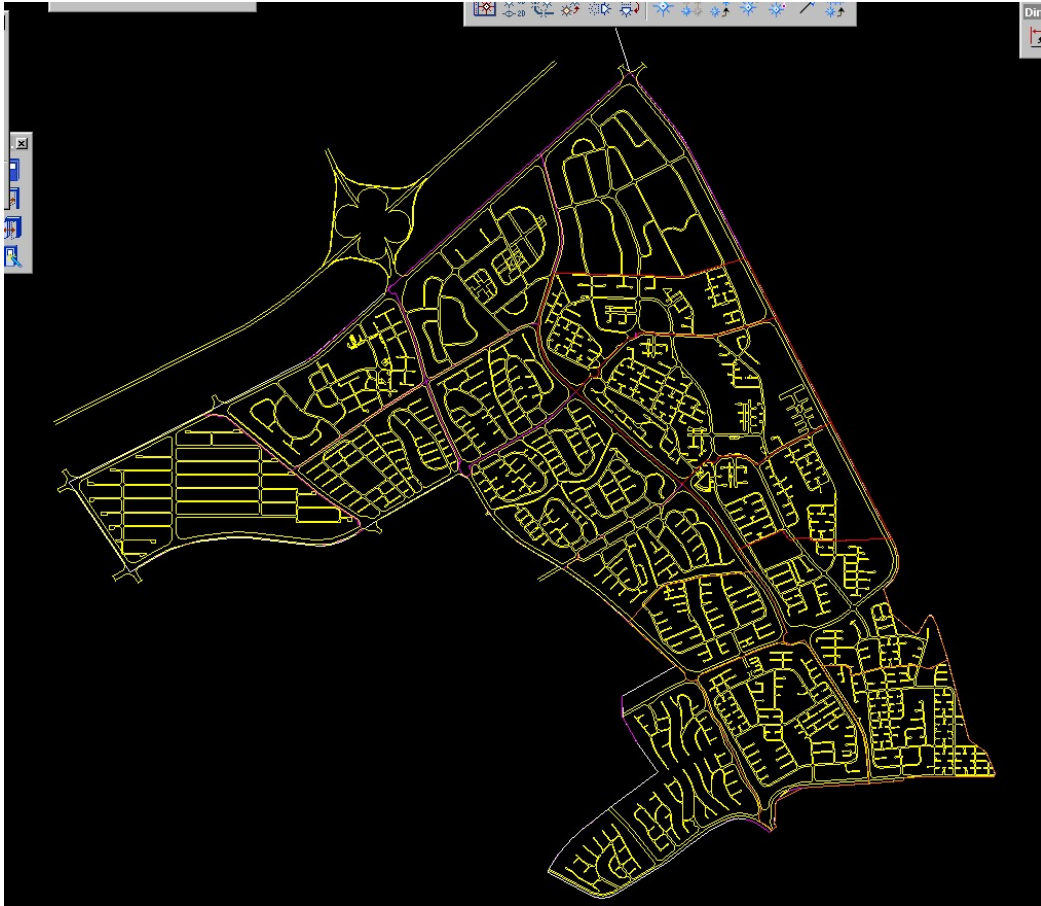

Fig 40: 2D CAD plan of the Hashtgerd New Town

4.4 Developing the VRCE Models

Once the VRCE full 2D plan is established, several 3D building models are created to form the VR city. However, since the proposed location (Hashtgerd New Town) is still under development, most 3D models used here are imaginary buildings placed all over the 2D plan to give the impression of a city-like feeling as well as some actual proposed buildings models.

Using Bentley's MicroStation, designing and inserting the 3D models is achieved through several methods and approaches to illustrate

different alternatives and explore proposed software capabilities. The first method which represents a large number of models used to form the VRCE is accomplished as MicroStation cells. This means each model is designed separately and saved as a unique cell in order to be inserted into the 2D plan in a specific location as required. The second approach is the directly built models that are designed and placed directly on top of the 2D plan which required less time and effort compared to the previous approach. The third approach which is relatively faster compared to the two previous methods, is achieved by copying some of the existing models (cells and directly built) and place them over the 2D plan as required.

However, all 3D models used to create the VRCE have been designed as simple 3D boxes with no details (doors, windows or materials) to minimize overall file size in order to be exported and illustrated by different visualization tools and methods (figures 41&42).



Fig 41: 3D models as placed to form the VRCE

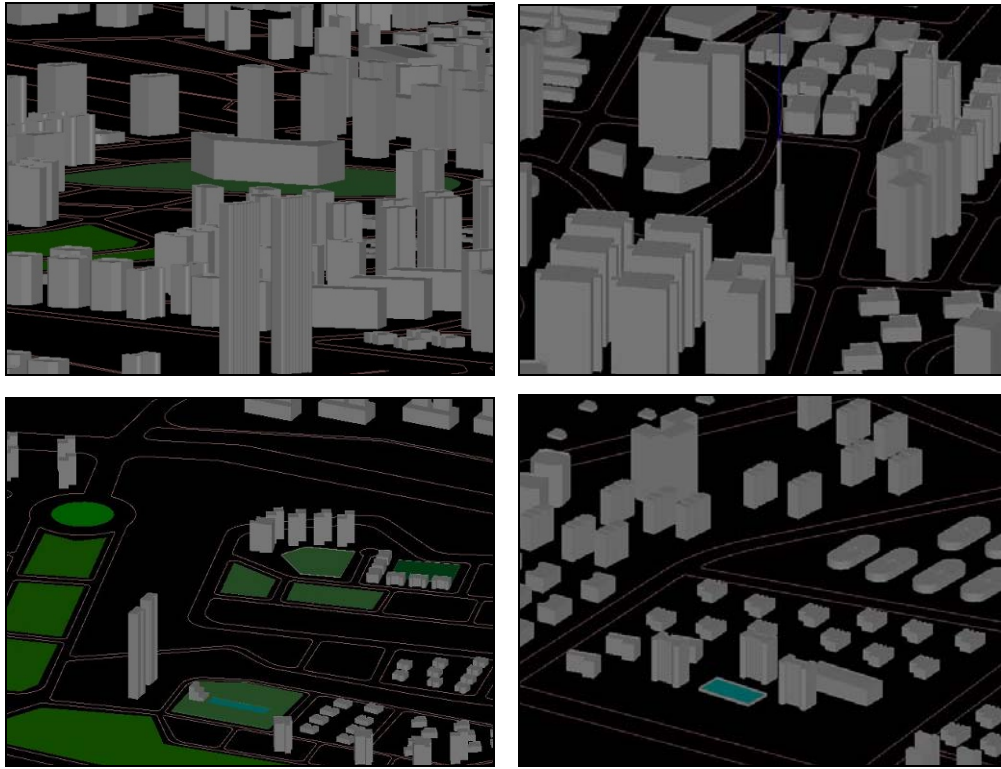

Fig 42: Simple 3D models developed differently to form VREC

After creating and placing all 3D models as required, the VRCE is ready to be explored and examined by different visualization tools and options. Three visualization tools have been determined for that purpose which will be explained further next and they are:-

1. The CAVE
2. On Screen visualization
3. Google Earth Tools

4.5 Visualization Tools and Methods

4.5.1 The CAVE

Viewing a large area such as the VRCE would usually require a suitable environment with reasonable screen sizes which most offered by the CAVE (Cave Automatic Virtual Environment). The CAVE is also referred to by AGC [70] as electronic CAVES or (computer-aided virtual environments), which was developed by the University of Illinois in Chicago and introduced in 1992 at the SIGGRAPH (Special Interest Group for Computer GRAPHics) conference. It is designed to overcome some of the earlier VR systems limitation such as the HMD's and the BOOMS (TM) and to be used as a useful tool for scientific visualization. The objective is to provide high resolution, a large field of view, and a stable display that did not restrict the number of viewers and would allow for multiple people to easily share the VR experience [9]. It consists of several computers and a room constructed of large screens on which the graphics are projected onto two to three walls and/or the floor where multiple viewers can look at a simulated image using a 3-D high-resolution audio and video environment. In order to see the image in a 3D format, LCD stereo shutter glasses and infrared emitter are used. The shutter glasses are used to ensure that each eye sees only the image drawn for it. In fact, the 3D model that appears on the walls is in accordance with the view point of the user with the tethered electromagnetic glasses on. However, only one set of glasses has the tethered on them, but the other viewers can still see the 3D models with the use of the shutter glasses without tethered [3& 85]. They only need to stay close to the user with the tethered glasses to

have the same feeling. In addition, this system also offers electromagnetic sensors on the wand which is the equivalent of a computer mouse to interact with the scene.

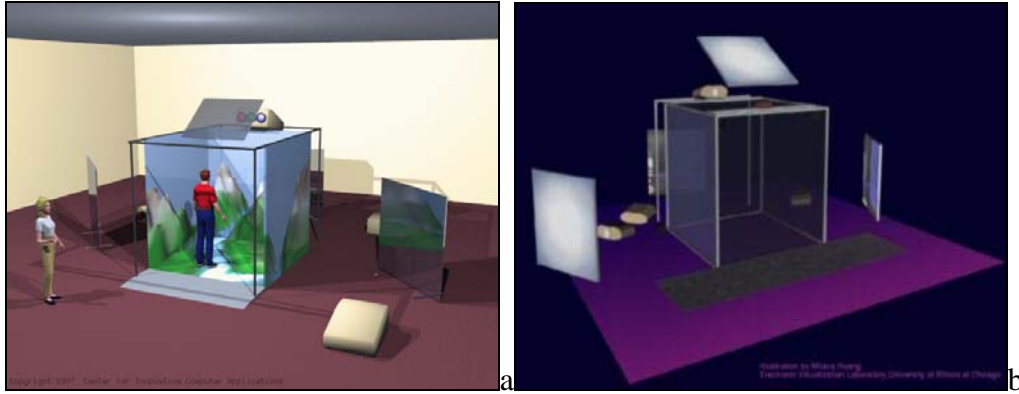

Fig 43: The CAVE (Cave Automatic Virtual Environment)

Sources:

a: http://inkido.indiana.edu/a100/handouts/cave_out.html,

b: <http://www.ev1.uic.edu/pape/CAVE/idesk/paper/>

4.5.1.1 Loading the VRCE to the CAVE

Although the CAVE that is available at TU Berlin has the same specification and equipments mentioned; it is being called Portal (copy right issue). However, it is not a complete room for it has only three walls (screens) and no screen on top (ceiling) as illustrated by figure (44). Also, the Portal software (jReality) is under development and increasingly steady with more functionality; however, no audio was required for this exercise [55].

The VRCE file was saved as VRML (Virtual Reality Modeling Language) world and then uploaded to the Portal system. With the provided shutters (sun glass like) the user can experience true 3D feelings. These shutters are equipped with a sensor that tries imitating human eyes; the scene moves according to the viewer's head

movement. Also, the system provides “wand” (a mouse like instrument) that allows for interaction abilities. The viewer can interact, move the scene, zoom in and out and move the model as required with help of the wand.

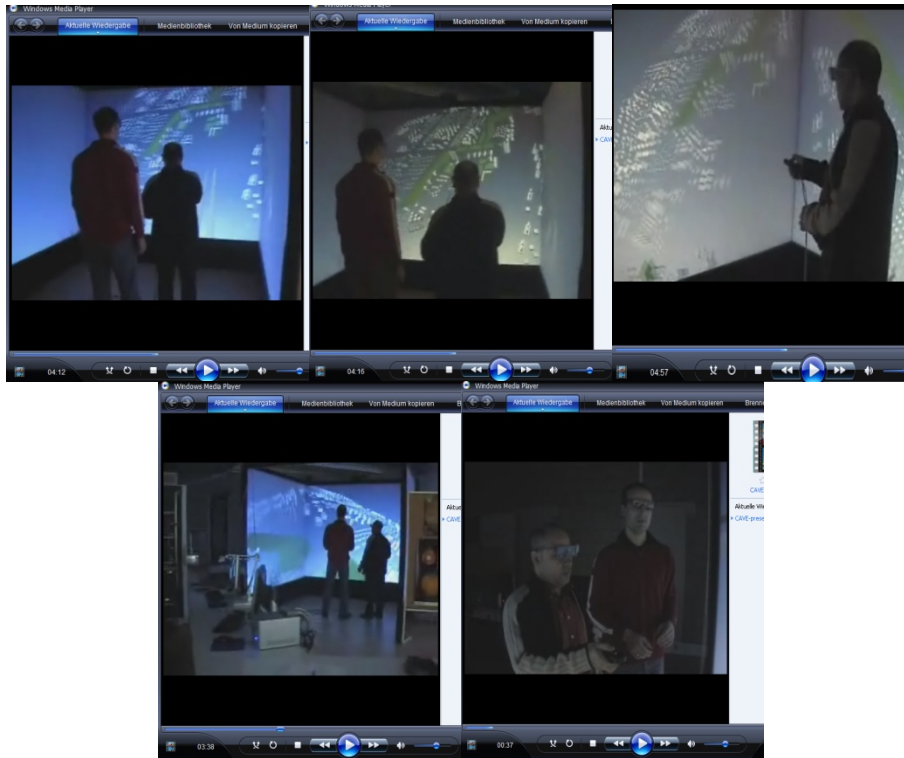

Fig 44: Screen shots of visit to the TU portal

4.5.1.2 Problems and issues observed during visualization

Some of the issues and problems experienced during this process are as listed follows:

- 2D data omitted by VRML: since VRML represents 3D data, all 2D data included with the VRCE such as lines which represented streets and properties did not import to the Portal. This has affected the overall scene of the VRCE in which only buildings models were shown without 2D data indicating roads

or properties edges. To overcome this limitation, all 2D elements that represent roads and properties edges were changed to 3D objects by given them thicknesses and heights. On the second attempt at the Portal after changing the 2D elements to 3D; the overall view of the VRCE looked better with roads and properties edges present.

- *Navigation and interaction*: navigation and flying through the VRCE was very slow and instable which is due to the large size of the VRC file and the portal's software which was still under development at the time.
- *Privilege over the use of shutters*: not all shutters (glass) used by viewers have sensors which is understandable. Only one user has this privilege which gives him/her the control to direct the model to his own eye directions.
- *Mobility and cost of technology*: the large size and high cost of the CAVE prove to be the biggest challenge researchers are facing. The CAVE is considerably expensive tool to own and its huge size requires a big room and allow for no mobility. It requires very expensive equipments, tools, occupies a large space and cannot be used, for example, on a job site easily.

4.5.2 PC Screen Visualization (MicroStation)

On screen visualization is the most common and extensively used method when dealing with 3D digital models. Since 3D models are generally designed and created by computers, it is most logical and quickest way to get first impression and briefing of the design is in the same environment (computers).

Therefore, the VRCE benefits from visualizing options and techniques offered by “MicroStation” such as walk-throughs and fly-throughs which are achieved on any computer screen. The on screen visualization is achieved in “MicroStation” by different methods and approaches. However, for the VRCE the walk-through is achieved by specifying a certain path around and through the VRCE 3D models as desired. Then, a fixed camera is set to follow the specified path to take a series of shots of the models along that path in the desire directions and angles. A total of 384 images were taking along the designated path and were saved as *.jpg images (figure 45). These images were then loaded to MicroStation’s video maker to compose a viewing video which could be then saved in a different format offered by the program (i.e.*.avi, *.wpg, *.epx, etc). However, for the VRCE the produced video was saved as Windows AVI (*.avi) which is provided as screen shots hereafter (figure 46).

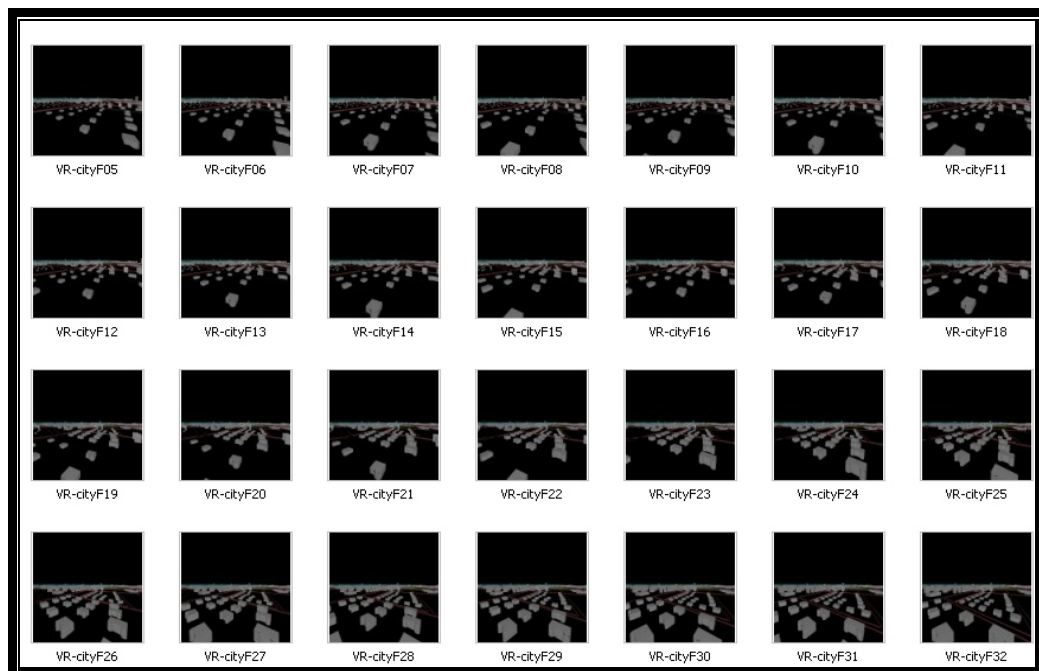

Fig 45: A sample of the images created along the walkthrough path

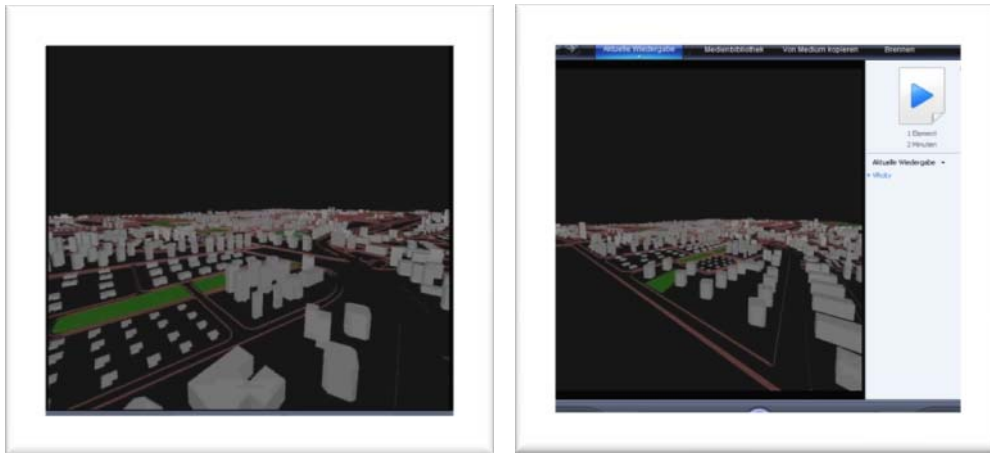

Fig 46: Showed snap shots of VRCE video

4.5.2.1 Advantages and disadvantages of onscreen visualization

Advantages:-

1. Mobility and availability: combining BIM software with a laptop or personal computer offers a mobile visualization tool that could be used conveniently almost whenever needed, such as on the job site or in conferences, which is not possible in many other visualization tools.
2. Relatively cheaper: in comparisons to other visualization tools and equipments.
3. No need for extra interference equipment: such as VR glasses, gloves or head mounted display.

Disadvantages:-

1. No surroundings (visual or sounds) is provided through the visualization process.
2. The small screen is not adequate for a large group of audiences.

3. It does not allow for immerse interaction for users as offered by other visualization techniques as in the CAVE for example.
4. Hard and software requirements. Realistic photo rendering usually required high-performance computers with high memory which is usually costly and not always at hand.

4.5.3 Google Earth Tools

Google Earth is an application from Google Inc. that provides 3D interface to view imagery from any location on Earth. Recently, MicroStation was connected to Google Earth to enable viewers to navigate 3D models in the context of rich geographic imagery. This includes tools that enable users to publish complete 2D and 3D CAD models along with geospatial data directly to the Google Earth format. Additionally, this link between Google Earth and MicroStation allow for the coordination of MicroStation Geo-Graphics data to be automatically export to the correct locations in Google Earth. Moreover, the rich environment of Google Earth which is serving as a graphical navigation device for all project content and graphical navigation will be more intuitive than a file structure. So, MicroStation user can export complete 3D models with geospatially located 2D data directly to the Google Earth tool.

“Bentley” claims, “MicroStation” is the first single-point solution to publish geospatially located 2D and 3D models directly to the Google Earth environment. By releasing a plug-in, MicroStation was able to publish DGN and DWG files to the Google Earth environment. It presents data to Google Earth as KML (Keyhole Markup Language) documents and XML based data structure for creating and sharing geographic data. In addition, exporting MicroStation geometry to KML

maintains the “Reference File” and “Level” (layer) structure defined in the model as well as saved views which are also saved as KML. This enables users to selectively control the display of levels or reference files within Google Earth environment. Moreover, Croser [8] indicated that connection with Google Earth will include all the richness of the “MicroStation” model content as follow:-

- ❖ All raster reference files are exported to the Google Earth service’s KML file.
- ❖ All model levels are carried to KML file so Google Earth users can easily switch part of model or desired levels on and off.
- ❖ All model saved views are also transferred to the KML file which allow users to view pre-configured perspectives in the model

4.5.3.1 Loading the VREC to Google Earth

The VRCE is exported to Google Earth as a free visualization tool to navigate and view the city in its context of rich geographic imager. The VREC was transferred to Google Earth as a KML which allows all 2D, 3D data and levels included with the file to be present in Google Earth interface.

The exportation process is illustrated by figure (47) and involves the following steps:-

1. First, creating a “placemark” in Google Earth at the required location and saving it as a “KML” file.
2. Second, using the “Define Placemark Monument” in MicroStation to define a monument point that matches the

location of the placemark that was already defined in Google Earth.

3. Thirdly, using the “Export Google Earth (KML) File” tool to export the file to a Google Earth “KML” file
4. Once the MicroStation file exported, Google Earth is opened automatically and it navigates to the location of the placemark and file.

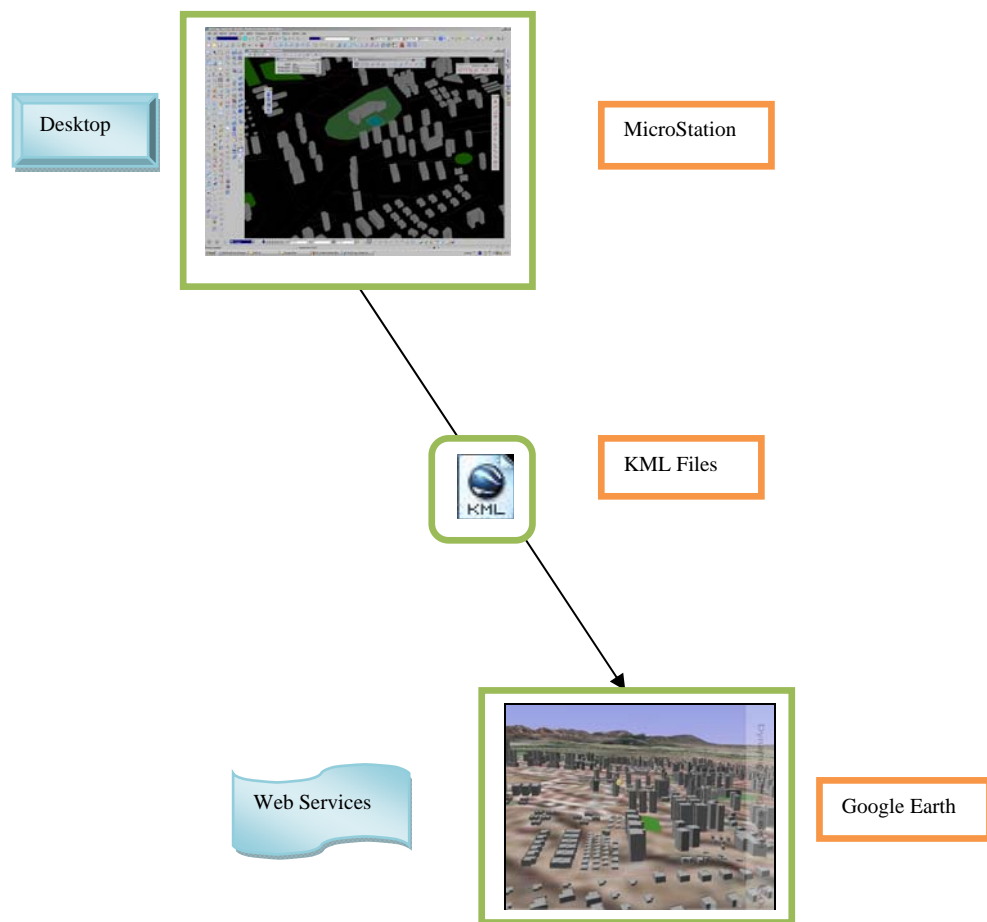

Fig 47: Illustrates the process of exporting the VRCE to Google Earth

However, the 2D plan of Hashtgerd was transferred along with 3D Models to show the geometry and terrain of the site which is not (as of this writing) shown by Google Earth. Usually, where terrains and geometry (i.e. roads, properties and surroundings) of a certain location are shown by Google Earth, there is no need to export 2D data with the models, because the models could be easily and effectively placed in their location. However, this is not the case here; the Hashtgerd Newtown location is underdevelopment and Google Earth does not show any terrains or geometry of that location as shown in figure (48). Therefore, the 2D plan of Hashtgerd is dropped on that location to compromise for that missing information as shown below in figure (49).



Fig 48: Hashtgerd location as presented by Google Earth

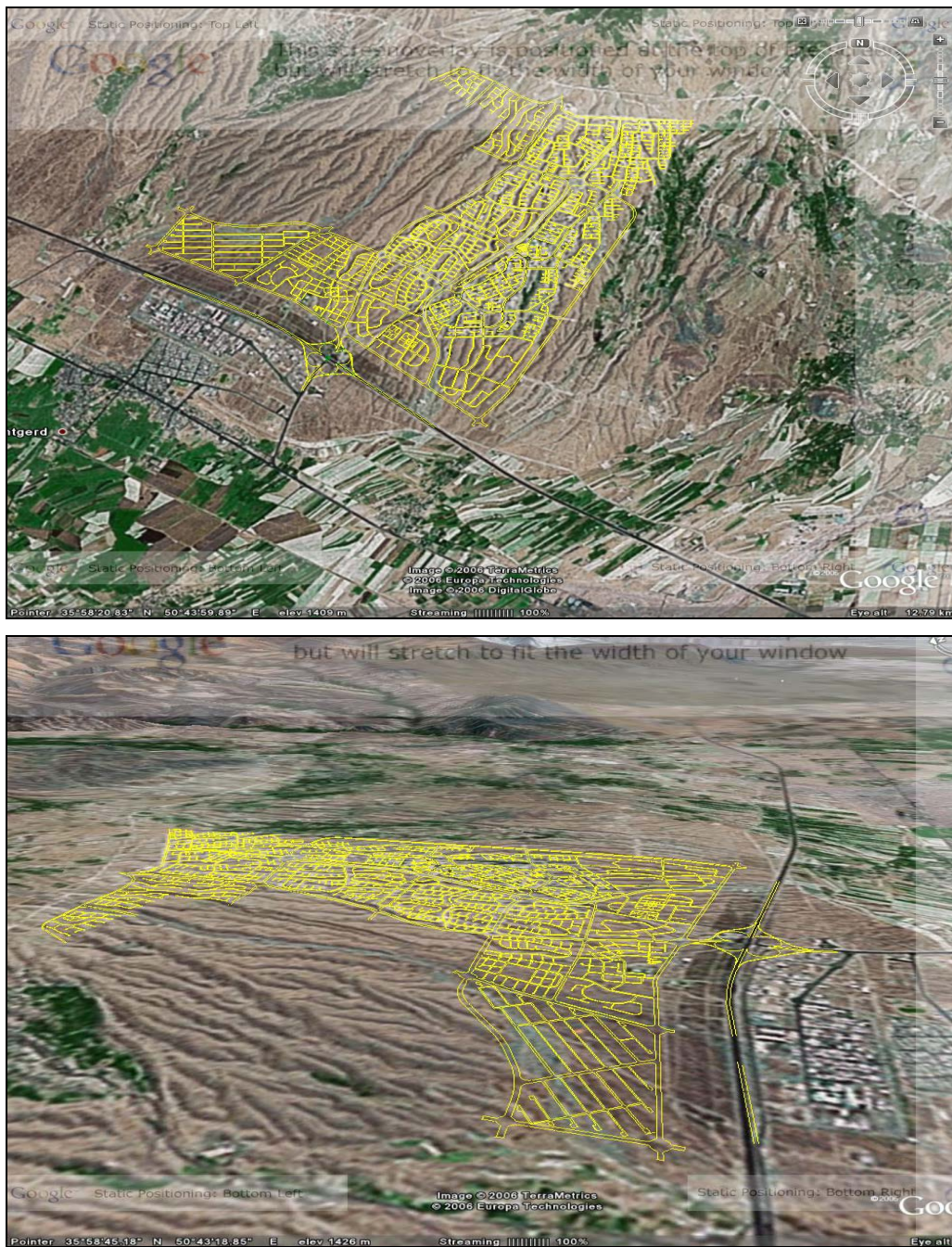

Fig 49: 2D plan of Hashtgerd as placed on Google Earth

Once the 2D plan of the city is placed in its exact location in Google Earth environment, the 3D models of the VRCE are exported to form the VR city. The final VRCE could then be viewed in Google Earth as shown by figure (50), allowing for navigations, walking through in real-time and exploring the whole city. In fact, users appreciate the richness, surrounding details and the experience offered by Google Earth which adds more meanings to 3D visualization. Also, shown along are some examples of more detailed models which are obtained from a proposed office building model that is being introduced in the next chapter.

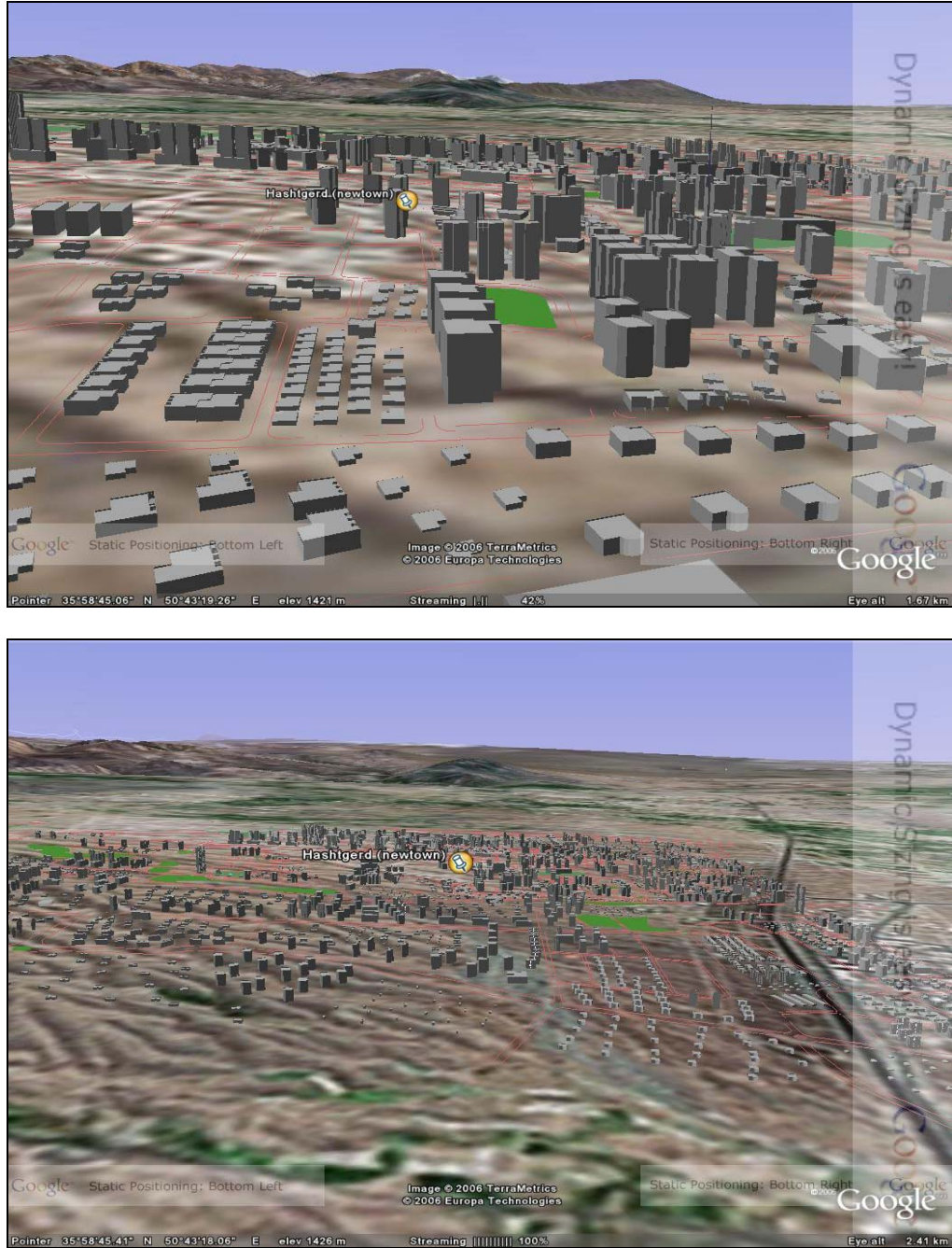

Fig 50: Visualizing the VRCE in Google Earth

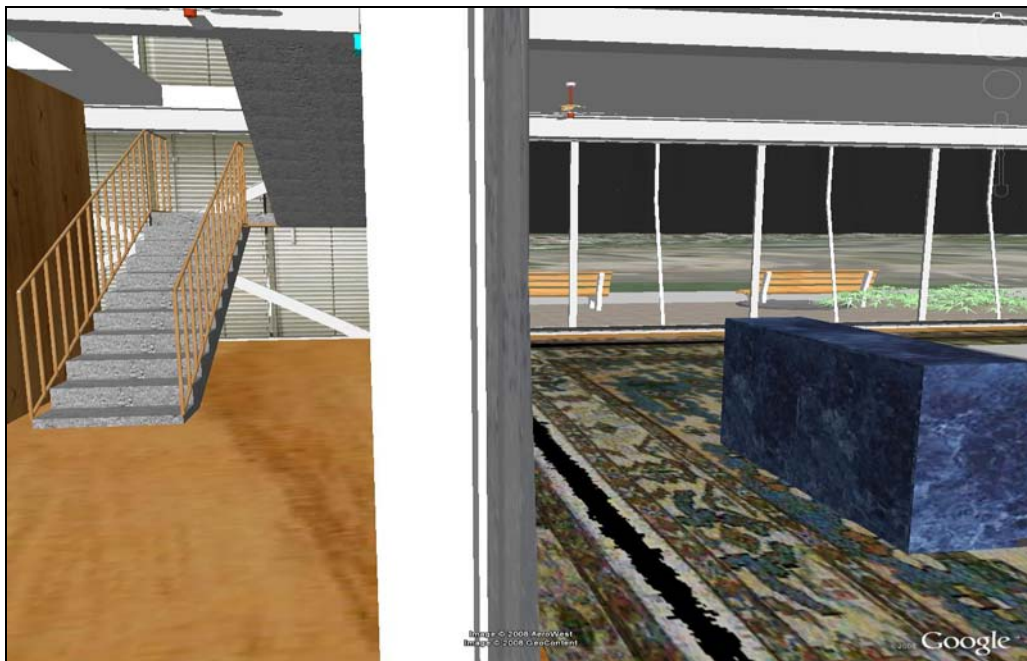

Fig 51: Visualizing detailed VRCE Models by Google Earth

4.5.3.2 Advantages and disadvantages of Google Earth visualization

Google Earth visualization method is generally rich in details and allows users to view their models inside the Google Earth environment. Its mapping service allow for broader AEC audience to gain a new perspective on infrastructure projects, and to leverage DGN and DWG data in an entirely different environment. It also, offers users an aerial view of geometry and geography and provides richness, accuracy and intuitive backdrop for AEC projects. Here the project can be viewed and navigated in the context of rich geographic, imagery with associated content such as surrounding buildings, transportation systems, boundaries, bodies of water, etc. Also, the exported file can contain links to more detailed data that users can review locally which can be provided in a variety of formats including, Excel spreadsheets, Word and PDF, just to name a few [8]. However, Google Earth enabled exploring the VRCE beyond ordinary visualization tools and methods. It gave the impression of real-like city and enabled viewers to walk around and explore the city in the richness of Google Earth environment. What is more, all data associated with the original file such as layers, saved view, etc. (figure 52) are also provided by Google Earth which allow users to switch layers on and off just like in a CAD program. Other important advantages of using Google Earth tool are:-

1. Google Earth is free.
2. Google Earth can show information (model) in visually fascinating way rather than in dry and academic way (reality like impression).
3. It allows for very flexible navigations in which users are allowed to achieve free range of motions and easy zooming.

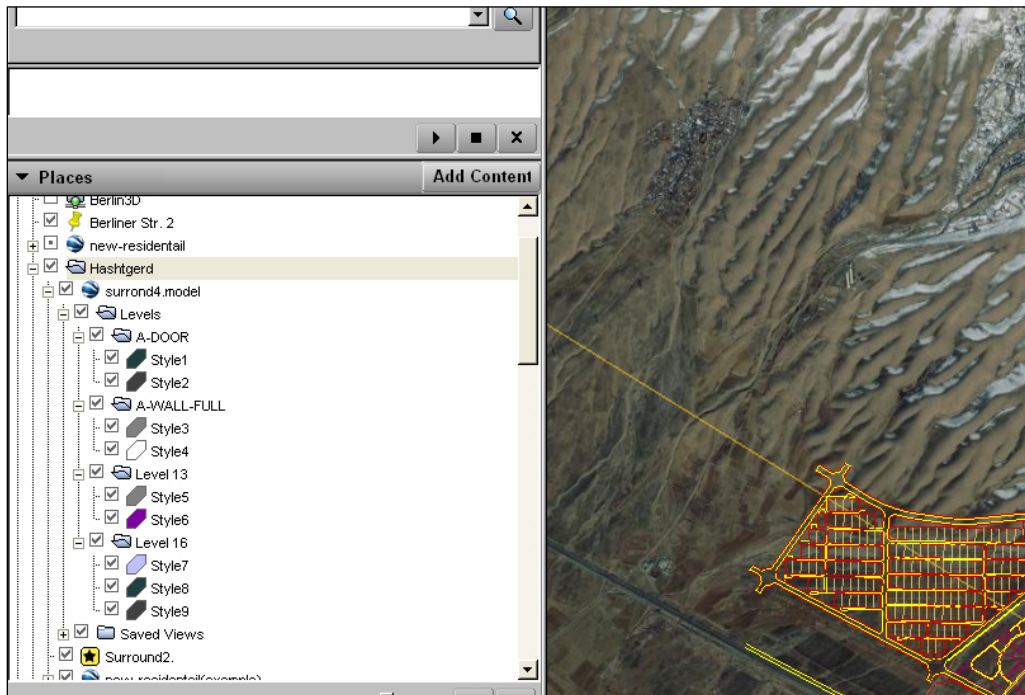

Fig 52: layers and associated data exported to Google earth

However, since this method is fairly new, there are still many obstacles and hinderers that must be dealt with in the future. Some problems and issues related to the process of visualizing VRCE in Google Earth are:-

1. Google Earth does not provide geographic imagery such as buildings, transportation systems, boundaries, bodies of water to all locations around the globe.
2. Models exported to Google Earth can only be smoothed rendered.
3. The geographic imagery of the existing buildings does not reflect the true height of these building which makes the exported model look awkward.
4. To play animation, users require third-party freeware.

4.6 Conclusions

Virtual reality technology is being used in the planning of cities and urban areas to assist planners and decision-makers better understand the dynamic functioning of the city, just as it has been used by other systems such as factories, airports and shopping malls [86].

While modelling a large-area city poses a great challenge to computer graphics, researchers and developers in this field are mainly focused on developing methods and solutions to cope with the high functional and visual complexity of large-scale cities. What is more is the generating of the 3D city itself including urban areas (buildings), transportation networks, surrounding environment, etc. which is coming rather cumbersome to designers. There are many approaches and systems that aim to model existing cities including the use of aerial imagery and remote sensing techniques to be able to generate the layout of a large-scale city based on 2D-input data. However, the effort of developing this VRCE was made very simple which involves designing simple 3D models of imaginary buildings including some actual proposed buildings. The aim was to demonstrate the significant benefits that could be realized by planners and decision-makers during planning process. It has also illustrated that virtual cities are an appropriate beneficial technology enabling engineers and decision-makers to view and navigate future residential or commercial development prior to construction. In addition, there are considerable benefits using VR cities when planning including resolve many problems or conflictions early in the design process which leads to better design and improve

overall time scheduling and meet project budget. However, the primary aim of this VRCE was also to investigate different VR tools and techniques that are available for use by participants of the AEC industry. Three different visualization approaches have been chosen (due to availability and affordability) to explore and illustrate different tools and alternatives available. While each tool has represented its own benefits and limitations, it is the use of these tools and their functionality to blame for a major portion of the encountered problems and limitations as explained throughout this chapter. However, next chapter will deal with a new emerging technology that originated from VR which is Building Information Technology (BIM).

5 Building Information Modeling (BIM)

5.1 Background

For thousands of years mankind have been interested in building construction projects. However, construction projects are typically too large for any one individual to tackle alone. Therefore, from early on, human began to think about ways to develop communications tools and skills to achieve projects. In addition, building projects are often very large and complex to plan, design and maintain which required many specialist persons with a great variety of skills and interests to cooperate in a common task. Ideally, since the ultimate goal of a construction project will normally reflect the need and wishes of the owner (an individual, a group of persons such as company or organization), the construction project team members need to related to the project and assist the owner to achieve the desire goals and business plan. Also, construction team members need to harmonize and agree to the owner's goals which require collaboration between all team members to achieve the eventual success of the building team [2].

In the beginning, there were drafting boards, T-square, rules and pencils. However, in the early 1980s, architectural firms started adopting computer-aided design (CAD) software. The aim is to support drafting automation very effectively and with little effort. Within a few years a large amount of construction documents and shop drawings were plotted from computers instead of being manually drafted on board. By the end of the decade, firms that didn't make the switch found it hard and costly to catch up. During the 1990s, 3D CAD

drawings evolved from the 2D CAD drawings to create 3D-views of the design and more advanced tools enabled engineers to design directly in 3-dimensions using virtual models. Soon became evident, that CAD advantages are well established and proven, with efficiencies in drawing reuse, organization, revisions, quality and consistency, etc. Although CAD originally emerged to automate the task of drafting, one starts to think of it as more than just an electronic pencil and paper. In fact, in order to achieve a certain level of consistency, this technology requires a great level of effort.

Next, object-oriented CAD systems (OOCAD) evolved which replaced the 2D symbols with building elements (objects) that capable of representing the behavior of common building elements. OOCAD aims to simulate building components in a CAD-based environment, focusing on the 3D geometry of the building as well as producing 2D document form the 3D geometry and extracting object data from the building components to provide quantity information and object properties [49&83].

Recently, the effort into making CAD products to be a complete repository for the storage, visualization, coordination, manipulation and extraction of relevant building information lead to Building Information Model (BIM) which is a single 3D model most commonly located within the CAD environment. In fact, BIM is the latest generation of OOCAD systems in which all building smart objects are stored in a single “project database” or “virtual building” that captures everything about that building. This is the newly emerged solution to ensure collaboration and communication between different project’s stakeholders at different phases of the design through the life-cycle of a facility. In addition, the use of BIM as a designing tool may help in realizing the team’s project goals and improve collaborations, communication and information consistency among all team members.

It would allow project participant to work on a single model where the entire data for a building could be stored, managed, coordinated, visualized, dissected and extracted. Most importantly, the model is not a collection of lines, but rather a collection of electronic objects that have relationship with other element in the model and know how they look and where they belong in that model [10]. However, BIM technology is not a direct replacement of CAD systems rather it is a natural progression from it. These issues including the concept of BIM technology benefit gains and barriers as well as related experiences and examples will be the subject of this chapter.

5.2 Objective

Using building information technology as a tool in AEC industry to generate building abstractions such as plans, sections, elevation, details, and schedules is the subject of this chapter. Mainly, this chapter will discuss the basic concept of Building Information Model (BIM), barriers, advantages and disadvantages, issues, related work. In addition, to exploring some successes projects and provide some valuable case studies. Finally, a BIM system for a proposed office building in Iran will be developed.

5.3 What is BIM?

The term BIM was first introduced by Autodesk in 2002, which is an emerging new technology with the potential to allow engineers and designers significantly improve the speed, cost, and quality of facility planning, design, construction, operation, and maintenance of their

design [20]. BIM is also defined by the National Institute of Building Sciences as:

A digital representation of physical and functional characteristics of a facility. As such it serves as a shared knowledge resource for information about a facility forming a reliable basis for decisions during its lifecycle from inception on ward [21].

However, BIM has many great potentials and benefits and it has being defined differently by different people in various sources. It is a new promising approach to the design, analysis and documentation of facilities. The main aspect of BIM circles around information management of a design process of a facility throughout its entire lifecycle from early design stages through construction administration and even into facilities management. Information includes all the design inputs such as: number of windows, the cost of materials, the size of heating and cooling equipment, etc. This information which is captured in a digital model can then be presented as coordinated documents, be shared across multi disciplines, and serve as a centralized design management tool [11].

Autodesk REVIT [22] defines BIM as *an innovative new approach to building design, construction, and management that was introduced by Autodesk in 2002*. It allows the constant and instant availability of a design scope, cost and schedule in high quality and fully coordinated format. Although, BIM is considered as an approach rather than a technology, it's supported to varying levels by different technologies. Also, Huw Roberts, Bentley Systems' global marketing director, stated: *BIM is not just software but a methodology of practice*. In other words, BIM means all project data is stored in one location which eliminates inconsistency and data overlap that may lead to expensive construction errors. This insures that every participant is working with

the same exact information as everyone else in the project and changes are made to objects only once. Handling project documentation in this way reduces communication problems that slow down projects and increase costs as well as, early findings of errors and inconsistency that typically discovered only in the field when engineers working with different set of drawings bump into each other [23].

Faulkner [12] identifies BIM as a completely integrated 3D model that allows users to define, detect and avoid clashes in a virtual world in which interferences are eliminated before construction ever begins. BIM is also considered as an approach to building design, construction, and management supporting the continuous and immediate availability of high quality, reliable, and coordinated information. He acknowledged that “a building information model is the ultimate compilation of construction and design information, housed in a database and graphically represented”. BIM functions in the way that interferences and clashes are discovered early, before impacting the final cost of a building. Utilizing specific software, clashes and interferences are found on computer rather on the job site. In fact, BIM technology dose not only impact those in the design and construction fields, it also stands to benefit owners as well, especially, sophisticated facility owners who already realizing the benefits of BIM.

In another interpretation by Smith and Edgar [13&17], BIM is a digital representation of the physical and functional characteristics of a facility. It offers a shared knowledge resource for information about a facility forming a database for decisions making during its life-cycle from inception onward. The concept of this technique is to build a building virtually, before building it physically in order to solve problems and interferences early in the design process. The model should be completed considering everything related to the building before construction whereby all conflicts or clashes between building

systems have been worked out prior to physically constructing it. In addition, it allows for participants to join in the development of the virtual building, for example the fabricators will provide the connection details building elements, as well as each participant will do their same job, simply more rapidly in a more collaborative environment. However, some people mistakenly define BIM principle as only 3D modeling and visualization tool. This definition is limited, since the concept of BIM is to be able to access all significant graphic and non-graphic information about a facility as an integrated resource.

Laasonen and Karlakari [14] among others refer to BIM as a file or database containing information about the concepts of construction, such as spaces and building elements which include wall panels, columns, doors, etc. Also, See [15] suggested that BIM should be thought as the building industry's application of Product Information Modeling (PIM) concept where the product is a building. It can also be thought of as a database of the building project.

However, Erger [16] argues that the definition of BIM remains a bit unclear because it is an evolving concept, although it allows more than just producing conceptual 3D models. The main aspect of BIM is the "I" in the middle "information" which is the foundation of BIM. BIM aims to develop a single project database that contains all project data, both graphical and non-graphical including all architecture, structural, electrical and mechanical systems information. By having all associated data in a single, continuously updated database makes it easier to manage and integrate all aspects of the project during the design stage. In fact, BIM adds additional dimensions onto existing 3D CAD techniques by attaching information to elements in the virtual building. Indeed, using BIM technique has extended beyond collision detection to focus on more functions such as real-time cost estimating. When linked to cost data program, project's budget can be tracked as

the design evolves. It is also possible to link BIM database to outside information resources, such as manufacturer specifications. He also added that BIM has been qualified as the design tool of the 21st century as well as the biggest thing since sliced CAD. Experts declared that this technology enables users to create well detailed 3D models that prevent guesswork out of the design intent and construction. Also, facility owners prefer BIM since it provides better visualization of the completed project and offer more documentation for continued building operation and maintenance. It also offers easy management and shared representation of physical and functional data that define buildings through their life cycles. For that, BIM is increasingly seen throughout the public and private real estate and construction sectors as a way to control cost and performance problems associated with inaccurate and incomplete communications [19].

DeStefano [18] adds, BIM may look like a CAD drawing but in reality it is something else. With BIM, the computer realize what is being drawing and what each line represent for example, unlike CAD systems where lines does not mean much, in BIM building elements can have attributes in which a line representing a beam correspond to a beam of a certain size and material and it may also include analysis data of that beam. What is more, BIM is a 3D parametric model of the building which means a revision of an element in the model will only need to occur once and the all views and details in the model are automatically updated. This eliminates the possibility of errors associated with inconsistency and uncoordinated drawings.

5.4 Benefits of employing BIM

It is beyond the scope of this research to cover all benefits and drawbacks associated with this technology; however the most encountered aspects will be addressed. Yet, shifting to BIM process promises many unthinkable advantages, thus BIM ultimate benefits are still emerging in the market and will radically change the way building are designed and constructed. In fact, the construction industry and its activities are shifting and architects are stepping up to the challenge. The shift is from traditional 2D abstractions to on-demand simulations of building performance, usage, and cost. This is no more fantasy but a practical reality. Now a day, all project participants are sharing a single database in which architecture, structure, mechanical, infrastructure, and construction are tied together and able to coordinate in ways never before possible. Also, the digital model can now be sent directly to fabrication machines to eliminate the need for traditional shop drawings as well as energy analysis can be done at the outset of design, and estimating construction costs are becoming more predictable and reliable. Also working in a model-base framework ensures that any change in any view will transmit to all other views of the model. This framework environment guarantees as elements are shifted in plan, they changed in elevation and section as well as removing a door from the model will simultaneously gets removed from all views, and the door schedule is updated. This enhances document delivery system enables extraordinary control over the quality and coordination of the document set [11].

However, architecture and construction have been developed for a long time now. Thus, the great number of participants involved in the planning and construction of a project makes communication and

coordination a complex process to deal with. Traditional construction methods are fragmented and lack the sense of reliability, especially when dealing with large projects. For instant, looking through a project documentations to find information about a particular aspect would be disasters due to lack of consistency of documents. Most times construction project documents failed to agree and match one another because a tradesman might have one set of drawings, while the architect may be using another set, at a different revision level. This guarantee will not happen in the building information model since all documents and views are produced form a single source when needed. The BIM is an intelligent three-dimensional model that is the core of the system. All parties involved in the project have access to the same data, at the same level of updating. Better still, the knowledge and familiarity about the facility grows as the project progresses in consistency and the virtual building expand to become better representation of the building itself over time. Moreover, actual construction documents can be produced from the model when required on screen or as hard-copy form. Also, architects and engineers can involved and elaborate on concurrent design process, certain that the model always reflects the latest decisions and everyone sees the same information. This also applies to contractors and tradespeople who can be certain that latest accurate documents are always available earlier than with traditional methods for take-offs for early estimates [23].

Additionally, working with a single 3D model during a project offers several significant advantages, many of which have already been proven in practice. However, most obvious is early identification and avoidance of problems through interference checking and visual verification. A single 3D model from which each discipline can extract information needed make for more efficient process, eliminate

duplication of work, less copies of identical information and less chance for miscommunication of intent [10]. Also, since the best means of understanding the construction environment is through visualization, BIM provides engineers with a 3D environment that echoes real live construction which means clearer communication of building design compared to traditionally used 2D drawings. Indeed, a fully formed BIM linked to supporting building data offers the capability for downstream use of building information for users beyond the initial AEC participants.

Also, the merge of this new BIM technology allows architects and designers to experiment with alternative design solutions and scenarios to optimize the expected cost. Equally important, is to derive ideas and new ways of maintaining the facility while reducing its lifecycle costs. Thus, BIM supports the potential of a design team to execute longer term return on investment analyses more accurately and far more quickly by providing architects and designers with information required upfront to make informed short and long term cost decisions. It also enables designers to swap materials of certain elements of their design (cladding or window) and the model will illustrate how these changes affect the overall cost of the project. More effectively, architects utilizing BIM technology can perform value engineering for clients either by reducing material costs or by illustrating that material choice will have a positive impact on total cost of ownership due to operating costs. In addition, architects and designers can keep track of economic variables such as interest and inflation rates, energy costs, and the potential for rising materials costs in the future. With BIM designers can execute these economic and design trade-offs upfront, eliminating repetitive design changes as drawings get passed to project participant. This reduces expensive changes during the construction phase of the facility [25].

DeStefano [18] added, BIM allows all participants of the design team to contribute and add information to a common model. Thereby, each participant adding layers of information to the same model in which is managed by one of the team members. Consequently, working on the same model will improve clash detections and identifies any collisions early in the process. Also, case studies illustrated that steel fabricators have been able to concentrate on reviewing the shop drawings and viewing more difficult areas in more depth rather than wasting time on re-inputting tedious data such as member sizes [10].

However, the early detection of construction collisions and interferences, enhanced with the use of computer generated simulation, the automatic generation of bill of materials and the designing of complicated models on computer have obvious benefits in the design, construction and facilities management of buildings as follows:

5.4.1 Benefits during the design phase

The 3D model developed by the BIM software is designed directly rather than being generated from multiple 2D views which can then be used to visualize the project at any stage of the designing process ensuring consistency in all views [49]. From previous experiences, it has been demonstrated and proven that maintaining and distributing data among a network of stakeholders in the construction industry results in data duplications and confusions. This is due to participants involved in the process such as architects, structural engineers and others independently maintaining their own information in the most convenient format for their separate activities. This trigger a disaster when it comes to design changes which in most cases, a management system can identifies them but they must be re-applied manually

because there is no automated option possible due to separate system being used by participants. BIM overcomes this issue by offering an approach in which all project participants contribute and work on a common model.

What is more, the widespread of “design and build” is encouraging the adoption of BIM and making it more attractive to companies and contractors to incur cost now in order to save cost later. Yet, BIM technology promises real cost and time savings due to reduced costs of communication and coordination as the project passes through each phase of the construction lifecycle [24].

Demchak among others [11] are also optimistic about the adoption of BIM into the construction industry, which offers designers and builders better tools to create, control, and display information. In additions, they listed the followings advantages users can expect to gain using BIM during the design phase of a project:

- Visualization enhances understanding the building and its space and allow for showing different design options.
- Integrated design documents reduce errors and improve documents consistency.
- Interference checking identifies conflicts between architectural, structural, and mechanical elements in 3D and eliminate costly errors on site.
- Automated up-to-date schedules of building components.
- Quantity take-offs of materials offers better predictability and planning.
- Easy to explore sustainable strategies and alternatives.

Clearly BIM provides architects and designers with the ability to realize design changes quickly, generate convincing 3D renderings and accurate construction documents, in addition to building lifecycle ability. Along the way, BIM can generate order forms, schedules, bill of quantities and more ... providing contractors with accurate quantities to accelerate their pricing scheme [26]. It gives also structural firms and structural engineers an integrated modeling environment for analysis and documentation, so that the structural design and documentation are always coordinated, consistent, and complete. Simultaneously, the ability to deliver existing architectural digital design data and share the structural BIM among architects and structural engineers further coordinates the building design and documentation in which benefit all parties involved in the design, construction, and operation of a building [12]. In addition, BIM is capable of embedding information relating to materials, lighting, energy, access, evacuation, ventilation, etc. which offer the opportunity to use this model for analysis and simulation, providing better information for architectural and design optimization decisions [29].

Obviously, having all project data in a single, updatable database would make data and accuracy easier to manage and integrate all aspects of the project during the design phase. What is more, project owners view BIM as a promise to offer a high quality project as well as time and cost savings. The ability to visualize the facility as a 3D model helps owners to gain a better understanding, early in the design process of the look of their final project. Also, any design issues or interference can be addressed early; and any revisions made during the design process can be updated within the database as necessary and changes are automatically integrated throughout the process [16]. Henry Tyler, CIO of Fairfax, V said in an article by Yoders [27]: BIM is a powerful tool because of its 3D designs capabilities to allow for

almost every decision regarding building's construction to be made early in the design stage of the project. In addition, using digital models during the design phase enable the design team to resolve systems-integration problems during design, long before the project goes into construction in which potential cost savings is realized [28].

5.4.2 Benefits during the construction phase

Although difficult to thoroughly measure and compare the productivity of different construction projects, the evidence suggests strongly that benefit of using BIM technology on the productivity of personnel during the construction phase is increased [29]. Using BIM should provide contractors and construction process participants during the construction phase more complete as well as more effective representation of design intent. This means, there is a greater chance that the finished project will look like the completed 3D model [16].

Williams [30] emphasized that BIM can provide material and equipment take-offs which means more accurate construction bidding, reduced change orders due to design errors and field coordination, and ultimately a building that better meets the owner project requirements. In addition, BIM provides the greatest opportunity for improving construction documents generation since CAD. Utilizing BIM as a modeling versus drafting tool forces designers to think more about how the building will be constructed in addition, automated coordination tools within BIM can detected clash and interference between building elements.

If properly managed and applied, BIM have the potential to be a powerful tool for the structural engineers and it enables contractors to build an exact replica of the electronic model of their facility.

DeStefano [18] believes that there is also the opportunity to import a BIM directly into a fabricator's shop drawing applications in which this data can be also used to drive automated fabricating machinery and element paper shop drawings. Fabricators will reduce waste because optimization of tasks such as cutting of sheet metal and pipe can benefit from all scrap pieces. Smith [13] added, construction sites are now safer because more building items will be pre-assembled off site and delivered to the construction site minimizing on-site trades activity. This means less waste on-site and products will be delivered when need and not stockpiled on site.

Moreover, it has been reported by the AIA (American Institute of Architects) conference in 2004 that a staggering \$100B is the cost of fixing and administrating construction "errors". Driven by cases where something done on-site differ from the intended specifications as planned. This extra cost occurs not only through the unnecessary rework on-site but also through extra time spent consolidating, checking, questioning and interpreting the multiple pieces of information generated from the specifications. Improving communications between participant and the way the design is translated into the physical construction phase could reduce or eliminated this extra cost. BIM has the motive and capabilities to deliver these savings [24]. It also enables construction mangers to determine how trouble-free the facility can be constructed according to specific design data. In addition, by linking the facility model to preliminary schedules they can evaluate the overall constructability of the design using simulation of alternative construction sequences.

5.4.3 Benefits during the management phase

Given that BIM is a relatively new initiative in the construction industry, there has, as yet, been little opportunity for owners and managers to quantify benefits in the operations and maintenance phase. Nevertheless, BIM technique offers key pieces of data about the facility that can be used to analyze building performance. For example, the designer could generate data from the model for use in calculating a wide range of performance, such as heat/loss gain, day lighting effects, air flow, emergency routes, structural performance and financial feasibility which means creating a closer linkage between analysis and design process [31]. Huel [32] claims that benefit of BIM go far beyond design and construction where information forms the BIM model has many potential uses in the life cycle of a facility. In fact, the true value of BIM becomes apparent once used in operating and maintaining the facility. More importantly, the model is a living entity which includes all important data related to the life cycle of the facility. Hence, a BIM utilizes digital technology to establish a computable representation of all the physical and functional elements of a facility and its related life cycle information and is intended to be a repository of information for facility management for maintaining the life cycle of a facility [19]. Harris [34] also believes that BIM powers go beyond improvement of the local construction industry to be a critical juncture for the industry domestically and internationally. Concerning today's critical industry issues such as energy conservation, environmental stewardship, and sustainability, BIM techniques allows for a common tool to dramatically improve designers and decision-makers response to these crucial issues. He argues that BIM will be most successful when information created during design and construction is regularly shared with operators and sustainers of facilities. This will allow for

data obtained by facility managers to be used throughout facilities long lifecycles and eliminate the re-gathering of information.

Brucker [88] emphasizes that BIM is not just a three-dimensional computer aided design model; it's a process of generating and managing facility data throughout the life cycle, from planning and design, operations and maintenance, through removal and smart recycling. The aim is to capture data suitable to each participant at each step of the life-cycle, making their jobs easier, more efficient, and producing better quality buildings. In addition, Smith [13] implies that once the BIM of a facility is completed, it will be delivered to the operator and sustainer of the facility and any modifications or improvements will be recorded in the model. Thereby, the model is the reliable source and will be utilized throughout the life of the facility to plan and tackle any modifications and changes. By serving as a repository for the complete life-cycle of a facility, BIM has the potential to be the best possible basis for facility management. Additionally, facility owners and managers are to gain the greatest benefits from using BIM including: better design scheme, more efficient construction, better control over processes, and the best possible documentation for facility management [23]. They could also benefit more by having well detailed models and schematics available for ongoing operation, maintenance and future renovation of their facility [16].

Moreover, BIM promotes cooperation by different stakeholders at different phases of the life-cycle of a facility. This cooperation includes inserting, extracting, updating or modifying information in the BIM to support and reflect the roles of that stakeholder. Still, an important objective of BIM is to improve business functioning so that collection, use and maintenance of facility information is a part of doing business by the authoritative source and not a separate activity [17].

Certainly, updatable models of existing buildings are an investment in information, in which maintenance of buildings effectively achieved. However, to ensure investment retains its value an effective and well-organized method for maintaining the information is required. Thus, the overall aim is that better information increases the effectiveness of use and maintenance of buildings. This merely depends on the status of the information which should be up to date and sufficient as well as information concerning the physical appearance of the buildings must also be available [14].

Moreover, Matta among others [33] stated that in the future BIM will allow designers and constructors to work collaboratively throughout the project delivery process, focusing on creativity and problem solving, while computers do the tedious tasks of counting and checking. In addition, facilities owners and managers stand to benefit the most, through the use of the facility model and its embedded knowledge throughout the 30 to 50 year facility lifecycle.

5.4.4 Benefits during Construction handover

Once a project is completed, the facility manager obtains many “bankers’ boxes” full of information about their facility at construction handover. This information is provided in paper format indicating all necessary data regarding the facility such as equipment warranties, replacement parts lists, building system operating instructions, maintenance job plants, and fixed asset lists. Whoever uses the information provided must pay to have this information entered into the relevant data systems and sometimes facility maintenance contractors are paid to survey the existing building to capture as-built conditions. This means the facility’s owner pays for the same thing

twice; once for the construction contractor to finish the documents at the end of the project and again for the maintenance contractor survey. East [35] interviewed public agencies as they confirmed at least one public building owner has paid three times for construction information handover. Firstly, project data is included in the cost of the completing of the design and construction of the project; secondly, the owner paid to have the construction documents re-collected at the end of the construction phase and provided in paper boxes along with the keys to the new facility manager; thirdly, since the paper boxes data cannot be loaded directly to maintenance management software, the owner has to pay for the operations contractor to survey the building again to identify existing equipment locations, serial numbers, etc.

In additions, there are several problems associated with the current construction handover procedure as follow:-

1. At the end of the project, construction contractors are ordered to recreate and gather information that has been developed by others which will induce errors.
2. Receiving the information at the end of the construction contract results in less than satisfactory deliverables, many of which are available earlier in the project, but not captured.
3. Inadequate exchange format preventing others from effectively using the data provided. Also, documents provided as paper format is often loss, cannot be easily updated and take up a large amount of space.
4. The information provided regarding replaced equipment is often insufficient to ensure compliance with design intent.

However, the new trend in construction information handover is BIM in combination with other tools. One attempt is using COBIE

(Construction Operations Building Information Exchange) which will be explained further later in the section “BIM issues and standardizations”. The COBIE is designed to work with BIM to exchange IFC-based facility management data that simplifies the work required to capture and record project handover data [91].

Another attempt using BIM to capturing data during design and construction of a project, and then handing it over to facility operators is provided by Brucker [88]. This attempt uses the Ifc Model Based Operation and Maintenance of Buildings (IFC-mBomb) which aims to bridge the gap between the design/construction of a building and handover to those who will be responsible for operation and maintenance. The intent is to develop a method that will allow a seamless flow of information to pass from design and construction to operation and maintenance - and then decommissioning and demolition if need be. In fact, this system allows a wealth of data on a building to be assembled, exchanged, stored, re-used and updated during the life of a building. It ensures that when a building project is handed over to the client, a seamless flow of information, stored fully and accurately in a model server, will contribute to the efficient management of the building.

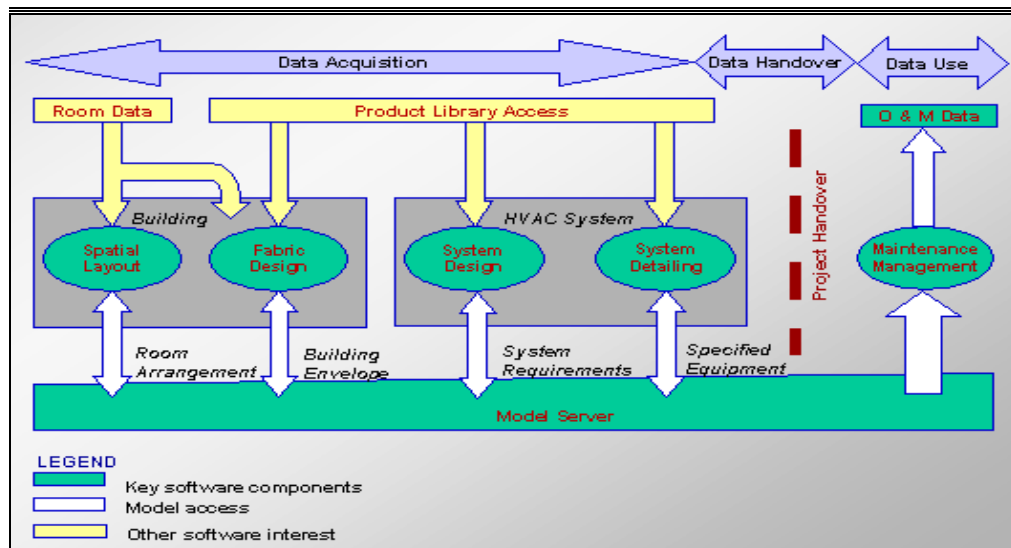

Fig 53: The “IFC-mBomb” project model diagram

Courtesy of: http://cig.bre.co.uk/iai_uk/iai_projects/ifc-mbomb/

5.4.5 More BIM benefits

Additional BIM benefits have been provided by Industry Directions [24] which could be realized by the AEC industry as follow:-

1. **Improved client communications:** better visualization tool offers by BIM technology and the ability to illustrate the different phases and options of the facility, speed client approvals of a design.
2. **Improve efficiency of the architects involved:** BIM allows architects to spend their time thinking about design, rather than maintaining a drawing database.
3. **Reduced time on drawing preparation and revision:** since the model maintains relationships between design information and final construction documentation, any changes can be updated

automatic and any needs for revision can also be notified by the system.

4. **Increased collaboration within the design team:** collaboration among project participants is a critical factor to risk reduction. It is based on the concept that all design team members' work on the same project with the same goals, in support of the owner's interests. Thus, the main idea of BIM is the opportunity for architects and engineers disciplines to work on the same model, allowing for early recognition of problems, and less surprises on-site.
5. **Reduced time to produce material takeoffs:** unlike current practices which use 2D drawing to achieve takeoffs, BIM can generate takeoffs automatically, delivering a quicker turnaround, more accurate estimates, and streamlining procurement.
6. **Reduced costs through increased standardization and modular-off-site construction:** catalogues linked to the project specifications can lead architects and engineers to use standard options. Discrete units, such as washrooms, may be commissioned off-site ensuring that they will fit first time.
7. **Improved efficiency of construction:** simulation of the construction can improve the construction planning process. This ensures feasibility of the planned sequence and achieves the best use of all resources. Using photogrammetric techniques to assess as-built status against plan facilitates problem solving.

Moreover, Hartmann and Fischer [36] in the 2007 AISC-ACCL eConstruction Roundtable Event Report, address the current situation of the AEC industry regarding the use and implementation of BIM in

which a number of projects utilizing BIM has been achieved. Many of these projects are able to realize these benefits:

- Higher productivity in the field gain of 20-30%.
- Less requests for Information (RFI) and Change Orders (CO) by a factor of ten or more.
- Higher engagement and buy-in of all important stakeholders.
- More design options from more perspectives with the same budget and time schedule than traditional methods.

Also listed by Wyatt [67] the following BIM benefits:-

1. Changes updated automatically: individuals within a single office and multi disciplines firms are able to automatically track changes. For example, an engineer imports BIM from the architects and changes the size of a certain structural member for strength criteria, when the BIM is sent back to the architect, the changes are automatically updated in the architect's BIM.
2. Saving time during design phase: only one model is need for a project, instead of several models in each design discipline.
3. Simplicity of tracking revisions and changes to the structure.
4. The availability of full information about the facility during its life time (Facility Lifecycle Management).

Additional benefits are realized through a recent study by the Stanford University Center for Integrated Facilities which is based on 32 major projects using BIM [88] including:-

- Unbudgeted change orders elimination up to 40%
- Within 3% cost estimating accuracy
- Up to 80% reduction in time to generate cost estimate.
- Clash detection techniques allow saving up to 10% of the contract value

- Overall project time reduction up to 7%

5.5 Barriers to the adoption of BIM in the AEC industry

Despite the obvious and well proven benefits as well as playing a key role in some firms' ability to operate more efficiently, the adoption and use BIM is still not widely spread within the AEC industry [10]. Indeed, there are several significant barriers that hamper the wide spread of BIM use, adoption, and implementation within the AEC industry as follows:

- **lack of understanding of what exactly constitutes BIM:** some people mistaken a 3D rendering with BIM and may be led to believe that interferences between systems has already being addressed where, in fact, they are only looking at a representation of building shell, nothing more.
- **Knowledgeable personnel are missing:** according to discussions and findings from the 4th eConstruction Roundtable organized by AISC and ACLL [36], many participants identify the lack of knowledgeable practitioners who are ready to move the industry into full usefulness of BIM as a major obstacle. Consequently, there is a need to establish training and educating programs to enforce the implementation of BIM across the AEC industry. In addition, the main obstacle that must be overcome is the integration of BIM across different phases and across the different participants of a construction project. Howard and Bjork [64] in their surveys on IT usage in the AEC industry, identify that educating of site operatives and students on getting

more information about BIMs is essential for eventual success of this new technology.

- **Legal and insurance issues:** there is no standard dictating the contents of BIM which acts as another obstacle to impede the wide scale implementation of BIM. In fact, the legal side of BIM implementation is a major obstacle that must be addressed as BIM technology evolves.
- **Fear of financial loss:** since BIM provides architects and designers with more data than has ever been aggregated on traditional projects, extra data requires a greater time commitment from both engineers and architects who are considered about recovering cost of this extra work. Edgar [37] talked about barriers to change to BIM from experience blaming that many firms are not aware of either the specific results of others' projects or the estimated value that could be created within their firm. He adds, even if firms become aware, they must be willing to invest a part of the future added value in a transition period and be willing to share some of the derived value with their new collaborative partners. When awareness and understanding of these conditions are achieved, acceptance and transition to BIM are successes. However, the lack of predicting BIM saves on project cost could also be an obstacle. Yet, BIM theory is a way of constructing a building virtually, before really building it, which identifies any conflicts whether in space, schedule or operational before they have impact on project cost. However in order to achieve a virtual building and its benefits, team members are assembled and reassembled several times to resolve conflicts and clashes. As a result, more

up-front time is required from designers team and contractors, the benefits of which outweigh the costs [12].

Also, additional barriers that obstructed the full usefulness of BIM in the AEC industry are presented by Bernstein and Pittman [38] as follows:

5.5.1 Transactional Business Process Evolution

BIM is efficient in the flow of information and communication process, but does not solve the business challenges. In addition, while the adoption of BIM technology in the building industry eliminates numerous potential conflicts, it addresses none of the underlying lack of basic business process integration. Besides, paper-based protocols include clear lines of business process in which are now unclear stated by digital-based protocols. However, there are basic businesses terms must be addressed and defined across the enterprise including:

- ❖ **Obligations** which focuses on determining each participant tasks, what deliverables required to achieve those tasks, and information generated and exchange in order to meet these responsibilities, etc.
- ❖ **Risks** would be difficult to assign when the originator of specific piece of design information cannot be definitively determined. Or as an open information project, can it be equally shared among participant. In an executive brief published by industry directions [24] which questioned the legal aspects of working practices and extra information handover. For example, the assumptions and calculations performed by the information provider may not be delivered

with the drawings to the information recipients. Therefore, if the recipients need this information, they must ask for it or reconstructed. Yet, BIM contrasts with potential complexities when a more integrated model is used to handover the information. This brings out the questions “will the recipients have access to the calculations or specifications used by the information provider? and what level of responsibility applies to architects, engineers, designers, fabricators and on-site construction teams who are sharing a data model? Which document or agreement will define these responsibilities? Also, Karp and Quinn [10] discussed legal and liability issues associated with Electronic Data Interchange (EDI) in which some engineers were advised by their insurance carriers against giving electronic files to other parties. In many cases engineers who handout digital file may request the receiving party to sign a “waiver” agreement to indicate that this digital file is simply an aid to help them but may have inaccuracies.

- ❖ **Rewards** if BIM technology improves construction process efficiency and productivity, the motive for integrating data and risk must be driven by compensation. Nowadays, model-based technology is realized in projects that are highly collaborative, where participant have to commence more often throughout the life cycle of the project. In this case, risk is distributed across the entire design team as well as the owner who joins in frequently by using the model as a design decision-making tool.

5.5.2 Computability of Digital Design Information

Digital design data is available in various formats; however, many of them are not computable. Interestingly, the term digital data does not automatically imply computable. Consider this, Computer-aided Design (CAD) tools creates digital drawings of buildings however, these drawings are only graphical representation such as lines, arcs, circles and polygons. These representations have only enough information for the purpose of plotting. This also implies to 3D models which are used only for visualization; the computer in this case has no implicit knowledge of building elements such as doors, walls, windows, roofs, etc. Therefore before the shift to meaningful BIM adoption, the request for computable information must be realized and understood and the building industry must transfer from pictures to information model.

5.5.3 Meaningful Data Interoperability

Interoperability refers to the exchange of information among project participants throughout the lifecycle of a facility by direct communication between software applications [21].

By definition, interoperability is the ability to manage and communicate electronic product and project data between collaborating firms' and within individual companies' design, construction, maintenance, and business process systems. It evolves from the highly fragmented nature of the industry in addition to the large number of small companies that have not adopted advanced information technologies [39].

To assist in this process, sharing meaningful design data between different applications is crucial. This idea of sharing design data is often introduced as “interoperability”, which is not clearly identified. Some proposed that interoperability is the development of a master database (model-server) that contains all knowledge about the facility. Other applications will work upon the final model to extract and produce information meaningful to them. This is a common way in the transaction-oriented business information IT applications such as airline reservation systems, accounting systems and inventory control systems. In fact, this approach works fine when data is well-structured and defined however, it has not proven to be a practical strategy for computable design information because of the following two reasons:-

- **Technically**, since there are only a few computable building design models available, makes it difficult to create one solution that works for every application. More importantly, the great complexity of such model-based data is much higher than in a transaction-focused database system. Effort to define data models up front often fall short because the ways applications use this information are not taking into account during the process. Also, the multiplicity of applications often makes it complicated to define the required data; so attempting to define a universal building model prior to implementation within real applications will possibly create a model that is too complex to implement. Certainly, the process of developing such models requires a great deal of time and efforts making it costly and ultimately suboptimal.
- The second reason is the **discontinuities of obligation, risk and reward**, discussed earlier, anticipate that one large database with unrestricted access is incompatible with current state of the

building industry. Controls over information flowing between participants are required to address the business realities of the industry which will evolve over time. Truly, the technical issues in managing controls on design information are far more overwhelming than those occur in managing transactional databases.

Faulkner [12] and DeStefano [18] define interoperability (also known as Electronic Data Exchange or EDI) as the exchanging and sharing of information among several software programs, from original format to another. In the construction industry, this means the ability to exchange drawings and models between different programs. However, there are many design tools available on the market nowadays, and many other applications that used to provide analytical insight of this design data. This should not be a bad thing, since it is harmful and doubtful that using one BIM system would provide all the capabilities necessary to address and solve the diversity and breadth of design and analysis problems in the building industry. Since, these types of systems that try to do everything often fail to accomplish anything right, and it is proven that purpose-built and focused data models and applications usually meet consumer's requirements far better. Additionally, purpose-built and loosely coupled applications will likely to precede innovation more quickly than with large, interconnected, and interdependent applications. Furthermore, Kymmell [2] argued that one could write a separate book about interoperability since it is important, complex and continually changing. Most importantly, the BIM practitioner needs to become informed about interoperability of the specific tools used on any given project; not according to the specification sheets of the software, but actually making the process work on several files is a necessity.

To further, the object-oriented tools to build integrated model has now been available for some time, however, the need to integrate the different participants involve in the process and the ability to share common information, have been a limitation on the widespread use of BIM [40]. In fact, Karp and Quinn [10] acknowledge that interoperability and EDI standards are true impediment to a BIM adoption. Due to lack of establishment and wide acceptance of current EDI standards, BIM has not been fully implemented in most structural engineering in North America.

5.6 BIM Production

There are considerable ways in which a BIM model could be achieved and produced. However, it is best to have the model produced by someone closely involved with the design process. By keeping the project learning within the project team, knowledge and understanding gained through the developing of the model will benefit the project team the most. Typically, a schematic can be created by a single person however, for a more detailed model usually more persons are involved. In some cases, the model is produced by “model shop” in which a set of documents describing the project will be provided to assist unfamiliar person to interact with the model and be able to build a simulation. However, producing such a set of documents and drawing describing the project consumes time and effort that could have been saved by producing the model internally by the project team and far more benefits and advantages are derived. Clearly, a designer will gain much less advantages having the model delivered by an outside consultant but, this is primarily done by construction firms that lack the necessary resources to produce models in-house. In this case, it will

quickly be realized that a lot of communication skills are required to be able to interact and develop accurate simulation out of the model.

Along the way, many questions about the project will come to surface only when someone attempts to model it, because accurate visualization is needed before modeling occurs; and since modeling process runs parallel to the actual construction process, simulation is a representation of the actual project and the main reason to create a simulation is to find all those instances that had not been anticipated or fully understood.

However, due to the variety of models involved in forming a BIM, interoperability issue is critical. To ensure interoperability and compatibility, involved models need to be produced in a compatible format to be combined in single software. Yet, an attempt to overcome this issue is addressed by NavisWorks (JetStream) which is a collaborative 3D/4 D Design Review software [41]. JetStream is able to view almost any 3D file format and combine it readily with all the other formats it can read. However, it is advised by Kymmell [2] to take these three rules into consideration when using JetStream:

- The first is to test a file through all the potential combination and software tools to ensure usefulness of the model.
- The second is to designate a common origin of the project so that all combined model will register properly in 3D space.
- The third rule is to avoid guessing only when there is no other alternative. In this case, guessing must be flagged so that others will know it and not rely on its being accurate.

5.7 BIM Software Solutions and Tools

Kymmell [2] addressed the various products with functionality in the BIM world which, are supplied by several major software developers' primary BIM tools for the construction industry. However, it is crucial to understand that many companies are competing in this market and their claims will need to be carefully examined before purchasing decisions are made by the customer. It is also not advised to purchase a product primarily on hearsay or assumed reputation without doing the necessary research to make a more satisfactory purchase. In fact, BIM is fairly unfamiliar field which makes it difficult to learn about a product and research its specifications before the purchase. This approach could easily lead to unexpected problems especially in this relatively complex area of BIM. In fact, the short history and complexity of BIM has produced many unrealistic promises and expectations, on both users and developers of the software tools. Additionally, companies attempting to save money by upgrading an existing software license rather than investigating other potential BIM tools could be making a costly mistake in embracing BIM technology. Therefore, purchase decision should be made depending on:

- 1) purpose of the software (creating models, manage and view models, or document productions),
- 2) user of the software (learning and mastering the software, frequent updating the software by developers),
- 3) file formats derived from the software (native format, exporting and importing from the software),
- 4) case study example that are closer to what is required.

However, provided below are a list of some software applications which, represent only samples of tools available on the market today.

Yet, software are continually updated and new functionalities are continually being developed and therefore the description of the listed software may be soon changed.

5.7.1 Bentley

Bentley offers software tools for design, fabrication, and construction for a long time. The main product offered by Bentley today is called “MicroStation TriForma” which is being used later in this research to develop a proposed BIM system. Triforma is an extremely robust and stable 3D platform that provides all requirements to produce and assemble construction projects. Bentley has a good reputation of providing clients and users excellent support and the well thought out software solution leaves no room for criticism. They only draw back is some users find it hard to master the software [2].

However, in an effort to assist users, Bentley dedicates a webpage for discussion group (<http://discussion.bentley.com/>), which I found very helpful. Novice users and advance users are coming together to discuss issues relating to this tool or answering each others queries. The good thing about this discussion group is besides getting professional users answering your questions, in my opinion, is the opportunity to discuss your enquiry with Bentley personal and software developers who join in the discussion and answer some of the questions posted by users.

In fact, Bentley claims its applications to help engineers, architects, contractors, governments, institutions, utilities and owner-operators design, build and operate more productively, collaborate more globally and deliver infrastructure assets that perform more sustainably [42].

5.7.2 NavisWorks

Earlier mentioned as collaborative 3D/4D Design Review software, which Kymmell [2] thinks is the best place to begin the initial explorations into BIM. “NavisWorks” functions just like a video game, and therefore it can limit the severity and number of things that can go wrong in BIM analysis. However, “NavisWorks” is not modeler software, thus it helps new users to learn to view, navigate, and understand virtual environments. In fact, the principal of “NavisWorks” is to provide 3D model interoperability for the AEC industry. Because the industry uses many different applications that all produce 3D models in different file formats which most do not exchange data to another’s native file formats. Therefore, “NavisWorks” has offered a model viewer that able to read almost any 3D file format. Typically, not everyone will be using the same application for everything; in addition, interoperability is vital for the successful implementation of the BIM process. For that, the challenges that face a project team due to the variety of tools used are addressed by “NavisWorks” as follow:

- It can read different files format from different sources.
- It combines different file types into the same file together successfully.
- It can import and handle large files.
- It facilitates graphical communications across the entire project team.

Moreover, “NavisWorks” handles large files and navigates through the virtual environments so effortlessly because it translates the model into surface models and removes some of the information (and most of the intelligence) from the original model. The surface model is usually enough to maintain all the visual data and perform sequence and clash analysis. As of this writing, no other software application performs

these tasks as well as “NavisWorks”; however, other software vendors are working on similar functionality.

5.7.3 Google SketchUp

“SketchUp” originally was developed by @Last Software and has swept the design industry by storm. It is free, simple, so powerful and mostly irresistible. Currently, it is owned by “Google” and it seems to be a supportive marriage. Although it could be used as a BIM tool, “SketchUp” is not trying to be one, it is a surface modeller. Therefore, users must keep in mind the limitations of this tool which related to type of information that can be contained in the model itself. “SketchUp” is not an object modeller although it can be treated like one; the components look like objects, but actually are just collections of surfaces that can easily fall apart. “SketchUp” ability to quickly convey the essential information about a situation (related to size, location, and look) into a 3D model makes it a BIM tool. However, the limitations of “SketchUp” have to be kept in mind, for it is not meant to be an information-rich modeller [2].

5.7.4 Autodesk

Autodesk’s “Revit” is their main BIM product. Kymmell [2] claims, it is probably the most widely used of the modelling tools; thus it is the newest on the market among tools discussed as well as the least mature. Autodesk’s strength is marketing; therefore it offers “Revit” as the next upgrade for their “AutoCAD” customers, although there is almost no continuity from previous attempts to address 3D modelling. Nevertheless, “Revit” has proven to be a serious BIM tool, and with

large user base expected to help in its further development. In addition, it is designed to link to “MS Project” and exchange scheduling information bi-directionally as well as the ability to export its model quantities to cost-estimating software. Demchak among others [11], added that most BIM products in today’s market are based on old technology whereas, “Revit” was designed from the ground up as a BIM platform to specifically address problems related to the AEC industry such as, communication, coordination, and change management.

5.7.5 Vico

“Vico” Software helps building owners and general contractors reduce risk, manage cost and shorten project schedules. “Vico” Software’s 5D technology provides unprecedented integration of design, construction and management processes, thus improving project predictability, providing early identification of constructability problems; and synchronizing design, cost and schedule. The company claims to have over three hundred customers and more than two hundred projects completed. “Vico” is fairly a new company, but “ArchiCAD” is behind its Constructor. It evolves as an independent company in March 2007 following the purchase of “ArchiCAD” from its original “Graphisoft” [43].

The software consists of the modeling engine “ArchiCAD” (a professional solid modeler since mid-1980), and several management modules including: Estimator (a cost database), Project Control (a Line of Balance scheduling software), and 5D presenter (facilitates project presentations). Most importantly, all these modules have a bidirectional link to each other and the model [2].

5.7.6 Tekla

“Tekla” Structures is the first structural BIM system which deals with the entire structural process from conceptual design to detailing, fabrication and construction. The software main aim is dealing with structural steel, steel reinforcing in concrete and precast concrete modelling. Its tools allow users to design and create an intelligent building model of any size or complexity. In addition, all drawings and reports are integrated within the model to generate consistent output. “Tekla” uses parametric modelling which means components contained in the model can be customized and edited at any time to suit the requirements of the project. It is relatively easy to learn and there are three models that can be added to its structures which are steel detailing, precast detailing, and reinforced concrete detailing. It also provides library components to allow for modelling any building components from the steel connections and fasteners, to the railings, stairs, and trusses; if a component is not available then it can be created from simpler elemental parts and saved as library parts also [2&71].

5.7.7 Nemetschek

“Nemetschek” main BIM product is “Nemetschek Allplan BIM 2008 for Architecture”, which is an object -oriented 3D planning software package for BIM. It addresses all commonly used design types, from simple 2D design all the way to virtual building modeling with integrated quantity take-off and cost estimating. “Nemetschek” alleges that unlike any other CAD software, “Nemetschek Allplan BIM 2008” symbolizes interdisciplinary planning by architects, construction engineers, design professionals and facility managers. In addition to traditional exchange formats, “Nemetschek Allplan” supports PDF and

IFC, which ensures a smooth data exchange process among planning partners [44].

5.8 Types of BIM

According to literature, findings, and previous researches, BIM could be classified into two main categories. First category includes BIM systems that depend on users participate in developing the BIM system models (i.e. architects, engineers, managers, etc.). The second category consists of BIM systems that evolve according to tools used in developing the system's models. However, the two systems are explained in more details as follows:

5.8.1 First category: BIM according to Participants

Four BIM systems evolved according to users' involvement, requirements and aims. These systems are listed by 4BIM [45] and illustrated hereafter:

5.8.1.1 Single BIM (x1)

A BIM model created by an architect is referred to as a single BIM model. In this case, the architect achieves automation of floor plans, sections, elevations, 3D views, visualization, and schedules from this model which is not possible traditionally. In addition, this single BIM model could be shared with other design team members although the benefits are limited to the architect and other participants would normally have no interest in taking advantage of the rich data. In fact, many architects and designers are using one or more BIM solution

however, because of the learning curve associated with any BIM software, architects are usually beginning solely with the architectural components before requiring it of the entire design team [63].

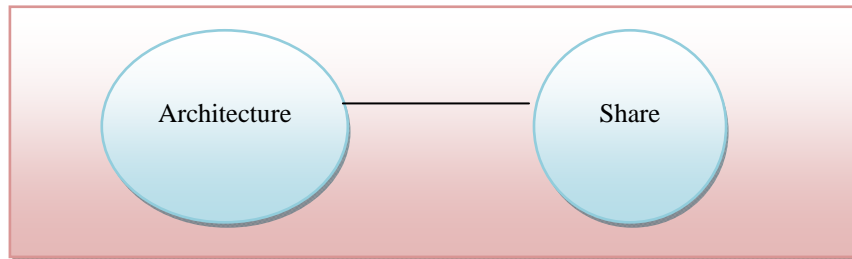

Fig 54: Single BIM (x1)

5.8.1.2 BIM (x2)

Benefits of BIM systems elevate when more than one of the design team work and share the same model. In this case, the architects and the structural engineers can gain benefit of the shared model to produce accurate engineering documents. For example, the building frame steel can be showing in the architects sections and concrete columns could be used by the engineering as well.

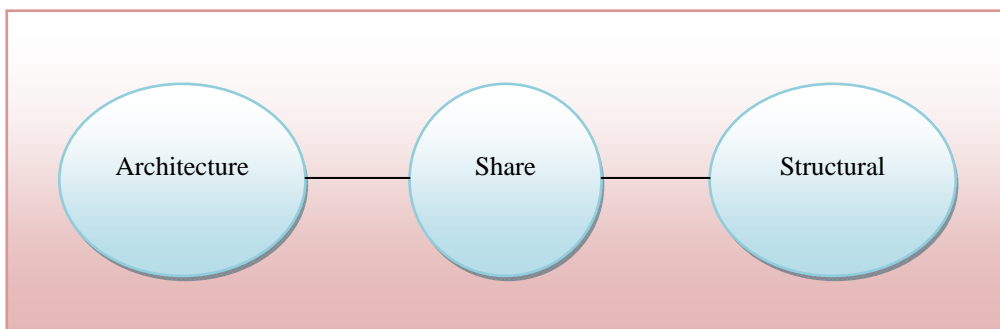

Fig 55: BIM (x2)

5.8.1.3 BIM (x3)

In this case, the service BIM is added to the architectural and structural to allow for the detail design phase of the project. Starting modeling of the services during the detail design phase of the facility will improve resolving of complex issues and insure that services spaces are optimized.

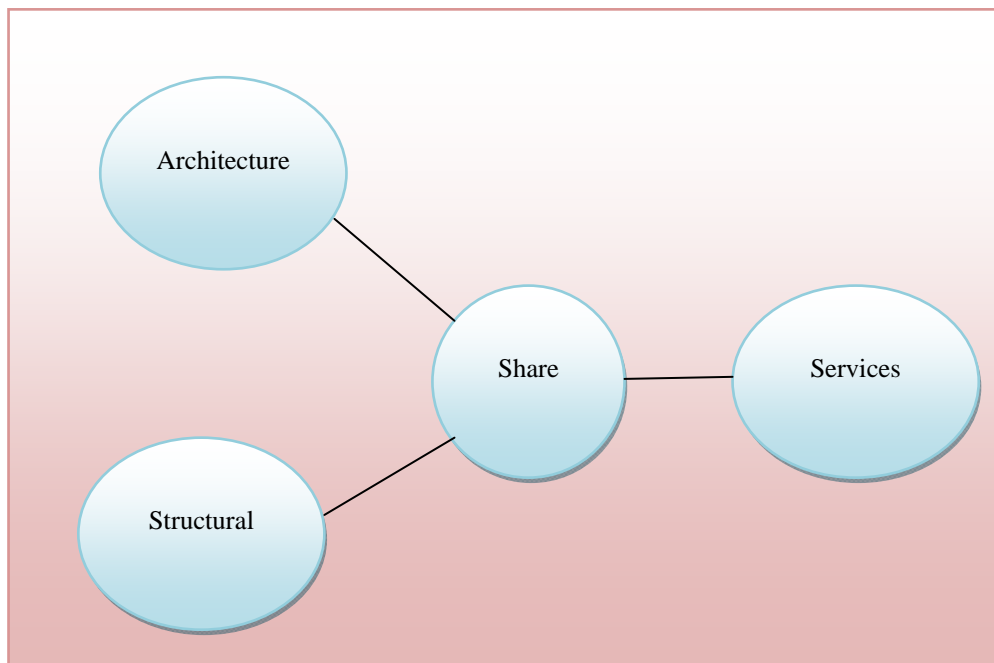

Fig 56: BIM (x3)

5.8.1.4 Multiple BIM

This is the most effective approach in which the design team, contractor, supply chain and the operator participate in sharing their BIM data. However, it is unlikely that all project participants are BIM capable and therefore, BIM standards need to be applied in this case. However, engaging all project participants in a BIM system is challenging but rewarding if all members agreed to do so. The data from the multiple BIM's can be used for cost estimation and document production as well as it can be used by the supply chain personal.

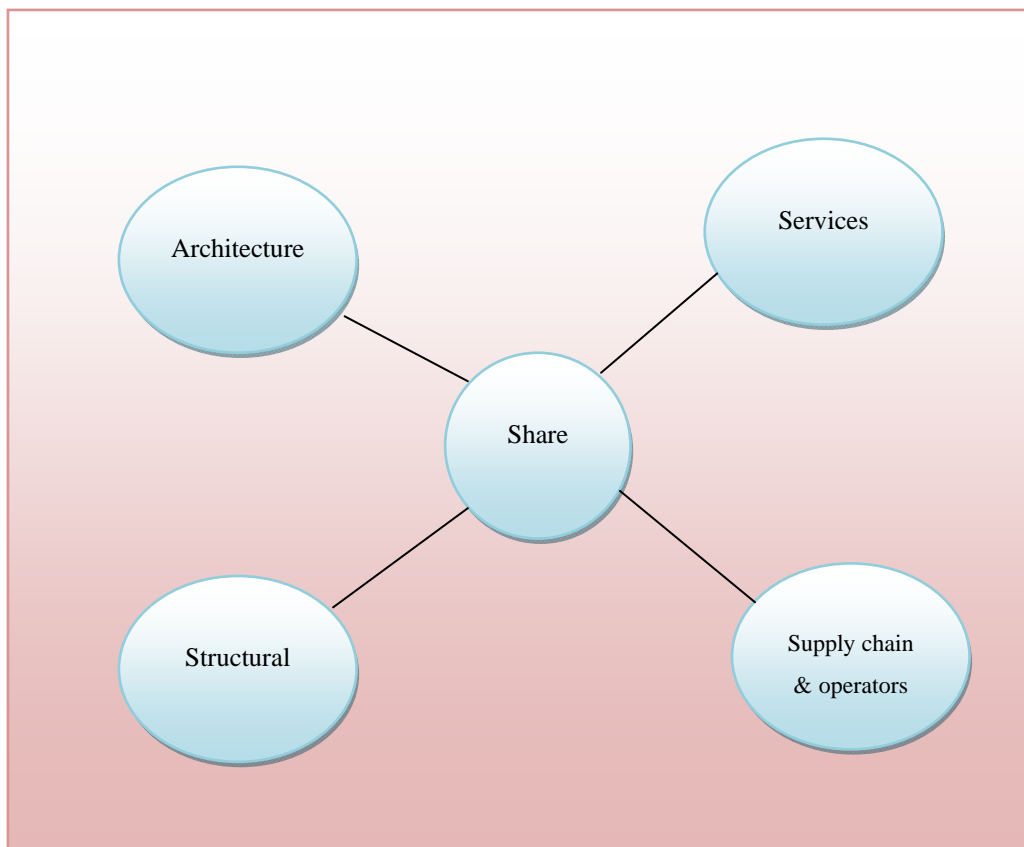

Fig 57: Multiple BIM

5.8.2 Second category: BIM according to Tools

The second category promotes two BIM systems that evolved according to techniques and CAD tools used to develop the systems. The two systems are further explained as follows:

5.8.2.1 Object-Oriented CAD systems (OOCAD)

The OOCAD BIM compliant technology uses object-CAD software that has been re-purposed for BIM such as Bentley Architectural, Architectural Desktop, Allplan, etc. Initially, CAD system aimed to automate the task of drafting mainly to replicate the traditional ways of representing building information. Therefore, the focus of CAD application was to represent 2D geometry via graphical elements, such as lines, arcs, symbols, etc. In this case, walls, for example, were represented as parallel lines and to establish some meaning behind these graphical elements, the concept of layering was introduced to group related elements together. For example, the lines that represent walls are grouped on a given layer (wall layer). This techniques, allow discrete 2D drawing files to be generated and plotted from CAD. However, more complex information, such as the relationships between elements could not be represented at this stage. In addition, the emergence of 3D CAD also ignored this relationship and focused almost entirely on creating geometry in support of visualization, and more advance concentrated on creating realistic rendering and lighting effects. Smilow [63] indicates that AutoCAD has greatly accelerated drawing production process and significantly improved accuracy over hand methods. However, these drawings are not “intelligent” documents since no information is stored about the building systems or

components. For example, a beam as produced by a 2D AutoCAD document would be represented as a single line. Although the beam size and related information could be shown as text adjacent to the drawing lines, there are no information about the beam is known or compiled internally within the computer memory. On the other hand, an intelligent document would also symbolize the beam as a single line with size information adjacent to the drawing line. However, the intelligent document stores the structural information associated with that beam such as size, length, weight, and other relevant information including all 3D properties.

Typically, Object-based data models define schemas that symbolize the structure and organization of project data in the form of a class hierarchy of objects. Utilizing of an object model offers consistence project information, and served to integrate different project aspects and facilitate sharing of data among project participants [46].

Recently, emerged OOCAD replaced the 2D symbols with building elements which are capable of representing the behavior of common building elements. Not only these building elements can be displayed in multiple views but also having non-graphic attributes assigned to them which add “intelligence” to these objects. This intelligence is achieved by including parametric 3D geometry which means walls are objects which can be stretched, joined, have height, be of a specific cross-section type, and “own” associated properties, such as a fire rating or insulation value. Also, windows and doors are represented as objects and have relationship with the walls in which they are placed and behaving accordingly. Indeed, realizing these relationships and intelligent behaviors are just not possible in the previous CAD paradigm [47].

Howell and Batcheler [47] also believe that BIM is the latest generation of OOCAD systems in which all building objects can be included in one single project database that captures everything known about the building. This makes BIM (in theory) the provider of a single logical and consistent source for all information associated with the building. Most importantly, OOCAD systems store some (nongraphical) data about a building in a logical structure with the 3D building graphics which assist users to produce information about quantities and attributes, just as they extract 2D drawings from the 3D graphics. Yet, object CAD systems remain anchored to graphics in which additional tools and effort are required to keep the graphical and nongraphical data in sync – to deliver the awaited benefits of BIM. Some of these tools used to identify inconsistencies and errors in data produced from object CAD models before the data is used for other purposes such as Solibri Model Checker. However, the larger the project, the greater the effort required to ensure co-ordinations and avoid inconsistencies [48].

5.8.2.2 Parametric building modelers

Parametric BIM objects consist of geometric definitions and associated data and rules in which geometry allows for no inconsistencies. This means, if an object is shown as 3D, the shape cannot be represented internally redundantly for example, as multiple 2D views. A plan and elevation of the same object must always be consistent and the dimensions are accurately guaranteed. Thus, parametric rules means objects are automatically modify when inserted into a building model or when changes are made to associated objects. Also, objects rules will report any changes that violate object feasibility regarding size, manufacturability, etc. However, the concept of parametric modeling emerged as an extension of Constructive Solid Geometry (CSG) and

Boundary Representations (B-rep) technologies based on university research and intense industrial development especially by Parametric Technologies Corporation® in the 1980's. The fundamental idea behind parametric building is that shape instances and other properties can be defined and controlled according to a hierarchy of parameters at the assembly and sub-assembly levels, as well as at an individual object level. However, parametric design is not designing an instance of a building such as a wall or door, rather it is defining a model family or element class which is a set of relations and rules that control the parameters by which elements instance can be generated. Typically, in traditional 3D CAD every aspect on an element's geometry must be modified manually, whereas in a parametric modeler the shape and assembly geometry are automatically adjusts to changes in context and to high-level user controls [49]. In fact, a parametric object is a smart object that can change its characteristics (size, materials, and graphic look) but is consistently the same object. It enables designers to effect a change of each parameter without affecting the others unless desired [11].

In addition, parametric modeling engines use parameters (numbers or characteristics) in order to determine the behavior of a graphical entity and define the relationships between model components. For example, "the diameter of a certain hole is 1 inch" or "the centre of this hole is midway between these edges". This indicates that the design criteria or intent could be captured during the modeling process and allows easier editing of the model and preserved the original design intent. Moreover, parametric modeling allows for network of relationships among and between all of the building elements and that illustrates its strength. The ability to record, present, and manage relationships between pieces of the building no matter where they occur in the building thrive this technology. A parametric building modeler

effectively manages the object data at the component level, but also enables information about relationships between all of the components, views, and annotations in the model. For example, a door to a stairwell can be locked in a specific place to ensure certain clearance from the riser; or a door can be locked at a specific distance from a wall to ensure furniture clearance or pull-side clearance for accessibility. Also, parametric modeling ensures that the entire model contains information, not only the objects creating it. In other words, a parametric building model combines a design model (geometry and data) with a behavioral model (change management) in which the entire building model and design documents are in an integrated database, where everything is parametric and interconnected. Most often parametric building modeling is compared to a spreadsheet where a change made anywhere in a spreadsheet is updated everywhere automatically. Indeed, no one is expected to have to manually update a spreadsheet. The same is true for a parametric building modeler where no one has to manually revise a schedule or design document produced by a parametric building modeler [48]. The power of parametric modeling is the ability to create relationships within objects and between objects. For example, walls can be attached to roofs, so when the roof is modified, all associated walls are automatically adapted to the new roof shape [11]. However, the most commonly encountered parametric building modelers BIM solutions are Autodesk Revit platform for BIM and Bentley Generative components etc.

5.9 BIM issues and standardizations

The first issue arises when it comes to BIM implementation is interoperability and compatibility among tools used to produce 3D models for BIM systems. While the benefit of BIM and 3D modeling

are well established and more firms are using BIM, each member of the project's team tends to have their own tool which cannot be integrated with the others, resulting in duplication of information and poor communication. Therefore, a common set of standards must be established and implemented by all software vendors in the industry to allow for better communications and to improve data exchange ability. Additionally, the AEC industry requires an established standardized process to successfully exchange and update model information.

A study executed by the National Institute of Standards and Technology (NIST) of the U.S. Department of Commerce, found that estimated \$15.8 billion a year costs the capital facilities industry due to interoperability problems in the industry [39]. However, some of the most important standards that are being researched and developed which aim to improve interoperability in the AEC industry are listed as follows:

5.9.1 NBIMS (National Building Information Model Standard)

In December 2005 about 50 individuals, representing different industry associations, developers and vendors, assembled under the National Institute of Building Sciences (NIBMS) to find a way to overcome the unacceptable losses due to inefficiency in the capital facilities industry. Those people and organizations have been working solo for many years to deal with various aspects of the problem and now they are gathered together to discuss the possibilities and benefits to be achieved by coordinating approaches to improve quality, reliability and efficiency throughout the facility lifecycle. Following that meeting, the formation and first products of the National Building Information Modeling Standard Committee (NBIMS) have been achieved [50].

In addition, since building information models are increasingly seen throughout the public and private real estate and construction sectors as a way to control costs and performance problems associated with inaccurate and incomplete communications, the NBIMS Committee objective is to facilitate life-cycle building process integration by providing a common model that contains and describe the facility information, common views of information and common standards for sharing data between businesses and their data processing applications. This common information model is expected to significantly reduce costs, insurance liability, construction schedules, and operating expense while improving performance and safety of facility. In this manner the Facility Information Council (FIC) of the National Institute of Building Sciences (NIBS) has formed a committee to structure a National Building Information Model Standard (NBIMS). The mission of the NBIMS committee is to improve the facilities over their full life-cycle by promoting a common standard and integrated life-cycle information model for the AEC industry and facilities managers industry. This information model will enable free flow of graphic and non-graphic information among project participants. The NBIMS targets current and future BIM users in the field of Architecture, engineering, construction, real estate, facility management and other related fields. In fact, the new NBIMS committee counts for 26 organizations and businesses and over 80 individual working group members. Now days, government agency and private organizations demanding integrated service delivery approaches, use of 'virtual building models' to reduce errors and omission, and the use and delivery of digital datasets for facility operations, maintenance and renewal to enhance emergency planning, management and response. He anticipates using a common and open building information model to facilitate these new demands and reduce delays, errors and liabilities

associated with the construction process, while improving performance, economy, safety and sustainability of facilities use [19].

5.9.2 IFC (Industry Foundation Classes)

The Industry Foundation Classes (IFC) data model is a neutral and open specification that is not controlled by a singular or group of vendors. It is an object oriented file format with a data model developed by the International Alliance for Interoperability (IAI) to facilitate interoperability in the building industry, and is a commonly used format for Building Information modelling (BIM). IFC allows information to be shared and maintained throughout a construction project's life cycle: design, analysis, specification, fabrication, construction, and occupancy [52].

Also identified by Brucker and others [21] as: *IFCs are data elements that represent the parts of buildings, or elements of the process, and contain the relevant information about those parts. IFCs are used by computer applications to assemble a computer-readable model of the facility that contains all the information of the parts and their relationships to be shared among project participants. The project model constitutes an object-oriented database of the information shared among project participants and continues to grow as the project goes through design, construction, and operation.*

IFC is recognized largely by professionals as a data model developed by the IAI (International Alliance for Interoperability) to simplify interoperability in the building industry. In fact, major CAD vendors were involved in the development of the IFC and its supporting tools,

which was developed to handle 3D file data. However, it is a data representation standard and file format used to define CAD graphic data as 3D real-world objects which enable engineers and designers to exchange data between CAD tools, cost estimation systems and other construction-related applications. It also offers a set of definitions for all object element types encountered in the building industry and a text-based structure for storing those definitions in a data file. However, in order to implement this IFC system, CAD vendors must create programming within their own software structure. Thereby, “Save As IFC” and “Read IFC” commands are provided, which map the IFC object definitions into their CAD applications to represent these objects [12].

Moreover, the IFC which was introduced at the 1995 AEC Systems conference in Atlanta, as the “common language for interoperability in the building industry” [15], is also acknowledged by Faulkner [12] as an open international standard allowing AEC software vendors and users to integrate and share data as well as combining all building components into one BIM. However, BIM systems which are capable of creating rich internal representations of building components requiring IFC to add a common language to transfer that information between multi BIM applications while preserving the meaning of information being transferred. This adds more value to the model and omits remodeling of the same building in each different application [51]. In fact, the IFC has been available for several years and as of May 2003 it has been extended to include new functions for structural engineers use. This is achieved in IFC 2x2 which incorporates standards for communicating information related to both steel and concrete structures [10].

It is believed that IFC standard will impact the wide usefulness of BIM by sharing these models across organizations, departments, IT systems and databases without becoming dependent on other products or vendors specific file formats. For example, the Danish government has made the use of IFC format(s) compulsory for publicly aided building projects, because of its aim to ease interoperability between software platforms and enable architectural CAD users to transfer design data between different software applications [53].

5.9.3 CIS/2 and IFC

The preceding section has briefly mentioned IFC 2x2 which incorporates standards for communicating information related to both steel and concrete structures. However, the IFC still lacks a sufficiently complete representation of structural engineering to be effectively used by structural engineers. Therefore, CIS/2 (CIMSteel Integration Standard Version 2) has emerged as another open standard that deals with one aspect of structural engineering which is steel construction. By definition, CIS/2 is a digital standard for electronic communication which originated from the Eureka CIMsteel (computer Integrated Manufacturing for Constructional Steelwork) Project, a 10-year \$50 million research and development project in structural steel that involved 70 organizations from nine European countries and further developed by the American Institute of Steel Construction (AISC) to facilitate interoperability within the steel industry [79]. This data exchange standard reduces the typical lead-time associated with structural steel, thus allowing users to create a model in one program's native file format and transfer all the components and necessary information to another program. In this case, and instead of starting from scratch in an analysis package, users can simply import an

existing model from different available design packages, ensuring time saving and eliminating duplicated data. CIS/2 is also a translator working as a bridge that allows software to communicate. For example, it enables steel bidders to avoid recreating the building digital model by using the model provided which shortens the bidding process significantly and ensures uniformity in the bids. It also eliminates the confusion of bidders presenting different steel tonnages in which the digital model clearly defines the piece count and tonnage of steel used. The only variation in material quantities that can occur is the allocation of steel connections which clearly identifies the tonnage associated with connection material. Any change required for other bid alternatives and updates are easily achieved via change to the digital model [63].

However since the CIS/2 standard was developed for the steel industry, inevitably though the questions come up: how does this standard fit into industry and what place does CIS/2 have in the future of the industry? The answer to that is BIM. There have been enormous efforts to achieve harmonization between CIS/2 and IFCs which will be an important component of BIM world. The aim is to have CIS/2 as the repository for structural steel data while IFC standard will be the repository for shared information in the BIM. Thereby, designers, owners and decision-makers mostly concerned with clash detections, avoidance and coordination issues will have access to high level, shared data housed in the IFC standard whereas, steel detailing, analysis, design and fabrication data will be housed in the CIS/2 model; allowing for a large amount of data, but only where needed [12]. In fact, the IFC and CIS/2 share the same roots and they are both closely related to STEP (STandard for the Exchange of Product model data), which was initiated in 1984 by ISO (International Standards Organization) to define standards for the representation and exchange

of product information in general. Also, both use several resource definitions (basic entity definitions such as geometry, cost, material properties, loads, etc. that are used to define the properties of higher-level entities) based on STEP and both applying the same STEP modeling language (EXPRESS) for developing and defining the model. Therefore, once BIM takes off and better interoperability is sought between the AEC industry as a whole, the IFC and the CIS/2 need to work closely together to improve the overall process of construction [79]. Both organizations - the IAI (for IFC) and the AISC (for CIS/2) have realized this and developed a translator to harmonize between the two standards. The CIS/2-IFC translator is currently being developed to handle three use cases:

1. IFC design to CIS/2 analysis.
2. IFC design to CIS/2 steel detailing applications.
3. CIS/2 to IFC for design coordination.

5.9.4 NSC (The United States National CAD Standard)

Reported by the buildingSmartalliance™ [89] and the National Institute of Building Science [90], NSC simplifies the exchange of design and construction data from project development throughout the life of a facility. It coordinates the efforts of the entire industry by classifying electronic building design data consistently allowing higher degree of communication among owners and design and construction project teams. The NCS primary aim is to reduce costs and produce greater efficiency in the design and construction process.

NSC “Version 4.0” is intended for owners, architects, engineers, contractors, facility managers, code officials, manufacturers, and

suppliers which added the following improvements to older NSC version 3.1:

- Expanded and reorganized CAD Layer Guidelines makes locating layers name easier in addition to including new telecommunications and electrical discipline layer names.
- Updated Uniform Drawing System includes new and revised symbols for geotech, security, masonry, plaster and updates and clarifies common drawing practices.
- Plotting rules are completely re-written which means line widths are no longer needed to be mapped to color numbers as well as new tables – gray scale, color, and line width tables.
- Additionally, the new version 4.0 includes documents in PDF, Excel, and .dwg file formats, making it easier to search and integrate the standard into CAD, BIM, costing, and other software.

5.9.5 COBIE (Construction Operations Building Information Exchange)

COBIE has been briefly mentioned as a tool used in the process of construction documents handover. It is based on an open-source platform (the IFCs) and designed to capture project information as it is created, rather than rely on post-construction surveys or audits as is current practice. Mainly to simplify the work required to capture and record project handover data. This approach operates by entering the data as it is created during design, construction, and commissioning as illustrated by figure (58). Information entered into this approach are provided by project's team; thereby the space, system and equipment layout are provided by the designer while product data such as make,

model, and serial numbers of installed equipment are provided by the contractor.

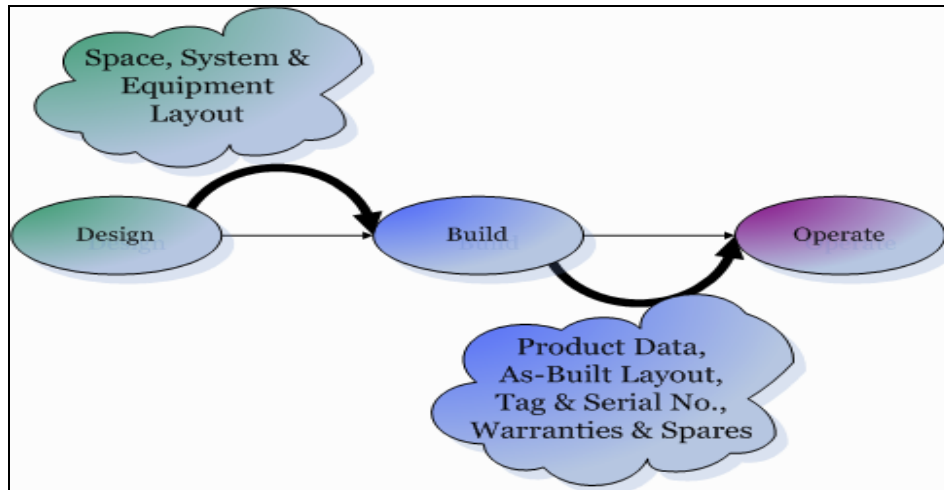

Fig 58: COBIE process overview

Source: <http://www.dtic.mil/cgi-bin/GetTRDoc?AD=ADA491932&Location=U2&doc=GetTRDoc.pdf>

5.9.6 SDNF (Steel Detailing Neutral Format)

SDNF is used in steel detailing, and has become almost a standard for data exchange between structural CAD systems. Unlike CIS/2 which was developed as a comprehensive exchange mechanism for multiple applications over the lifecycle of steel design, analysis, detailing, fabrication and erection, SDNF supports the exchange of a steel structure design between two applications. It is a standard format for the exchange of steel structure elements (steel sections, plates etc.).

5.10 Related Work (Real life situations and examples)

5.10.1 U.S. Army Corps of Engineers (USACE) is going BIM

The U.S. Army Corps of Engineers (USACE) is implementing BIM technology to its military and civil works processes. It has arranged for the transformation process of Military Construction (MILCON) using BIM as a new approach to its design process insuring that by the year 2008; BIM will be required for all military construction projects. They believe that utilizing BIM technology will assist design and construction activities to meet the critical deadlines of the MILCON transformation process. However, the benefits of this new technology are not limited to design and construction; but there is also the potential that information contained in the BIM model could be used in the life cycle of the building. In addition, data used during the design of the BIM model can assist in the operating and maintaining the facility surrounding the infrastructure.

However, when linked with systems that support life cycle management, BIM allowed the USACE to better support its customers. For instant, they used data from the BIM model to assist in installation management and operations [32].

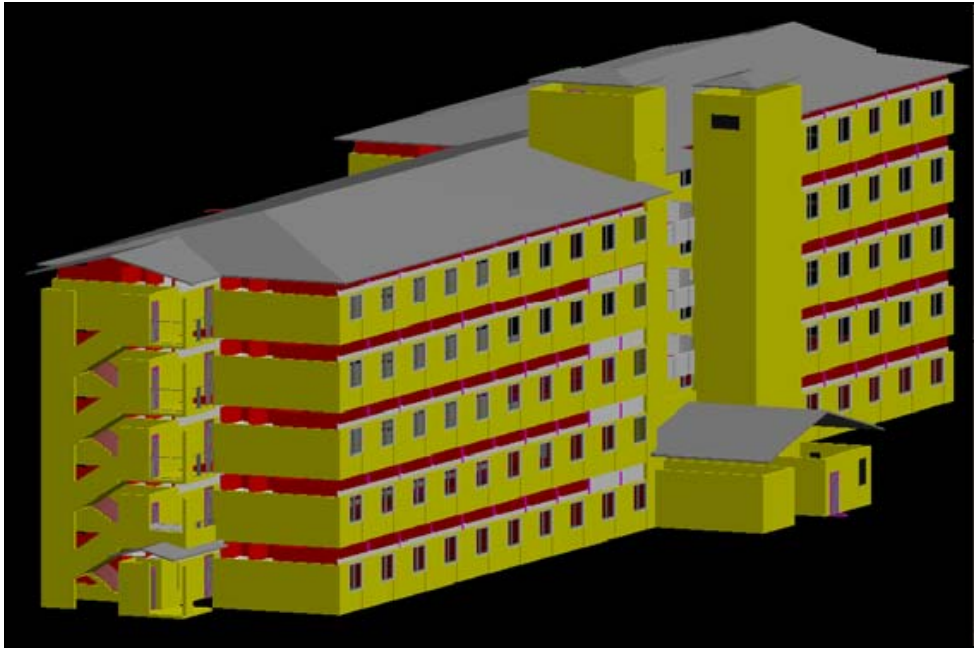

Fig 59: Military Barracks BIM Model (USACE Honolulu District)

Source: https://caddim.usace.army.mil/MyFiles/EdwardHuellBIM_FINAL.pdf



Fig 60: Fort Lewis Barracks, Seattle District

Source: http://www7.nationalacademies.org/ffc/mk_miles_usace.pdf

Implementation issues encountered

Currently, the Centers of Standardization (COS) produces models with information belonging to the rooms within a facility in order to generate schedules for the construction drawings. On the other hand, Administrators of Installation Management Systems (IMS) typically field survey a building after construction to determine the layout of the building and collect other vital information. However, this information has already been collected by the COS during the development of the model but lack of communication between participant lead to redundancy in effort and therefore, wasting time and extra cost encountered. Thus, information composed during the development of the BIM model could used to support the IMS requirements.

Therefore, it is recommended that customers, owners and operators should be involved in the BIM process to ensure collection of valuable information to determine its impact on the BIM model. The interaction of all entities early in the development stage, enable information to be utilized in manners that are beneficial for the life cycle process.

5.10.2 New innovative office building in the heart of Vilnius, Lithuania

The SBA Group new innovative office building in the heart of Vilnius, Lithuania is one of the major construction projects which utilize BIM solution [54]. This project was scheduled for completion in the first half of 2006 and is estimated to cost \$20 million. Denmark-based PLH arkitekter, which was chosen to produce the detailed design, has decided to design the new office building using Bentley's information modeling (BIM) including Architecture. One reason for PLH's selection of BIM solution was the flexibility that offered to the designers and the architects to sketch the unique forms envisioned for

this building. Especially, helping architects in designing the main bearing structure, which consists of eight intertwined steel helixes that stand together as a unified tower around a central atrium. Using BIM solutions proved to be a flexible and quick approach for sketching this structure allowing for producing a series of models for evaluation in very short time frame.



Fig 61: SBA Group new innovative office building (Vilnius, Lithuania)

Source:

www.bentley.com/itIT/Products/Bentley+Architecture/Project+Gallery/Image+gallery+PLH+SBA1.htm

What is more, PLH won the designing competition amongst Europe's top architectural firms by producing a number of different concepts from many different views for evaluations and the best concept was selected to be their entry in the office building competition. The 3D model was designed so that several architects could work on it at the same time by dividing this model files into building parts and all individual models were referenced into the main model to the entire building.

In addition, PLH agreed to use DWG as the data exchange format since they use Bentley's BIM solutions to generate production drawings and the building engineer (Ramboll building and construction) uses DWG-based software. This eliminates the need for PLH to double-produce the steel portion of the model by referencing the Ramboll's DWG-based steel model directly into the PLH BIM main model. However, due to the limitation of DWG-based systems, only the geometry of the model and not the inherent intelligence behind the objects could be exchange.

Overall, the major benefits of using BIM solution were the constant geometry check of the model parts and their relationship. It was possible at any time during the process to inspect design solutions and evaluate these solutions for aesthetic and functional value. Also, visualization in the form of still images and animations could be produced on day-to-day bases. PLH acknowledge the benefit of using BIM solution without a doubt. In fact, the production drawing started early in January of 2004 and was completed by April 1, 2004. It was clear after only a few weeks' work that the designing process went far beyond what could be accomplished by traditional 2D methods. While this project could have been drawn in 2D, these factors must be taking into consideration if the project had been drawn in 2D:

- 1) the man-hours would have been at least doubled,
- 2) the time required would have been extremely high,
- 3) errors because it would have been so difficult to maintain consistency between the different views.
- 4) the same level of detail could not have achieved using 2D method.
- 5) the series of constant geometric control checks that come inherently from the 3D model would have been impossible to achieve by 2D techniques.
- 6) the drawings generated from the 3D model presented a high level of sophistication, detail, and accuracy that is seldom seen in traditional 2D drawings.

Additionally, PLH realized that using BIM solution as the basis for the entire design process saved them time and improved accuracy. They have completed this project in about half the time that would have been required using conventional 2D methods, because they were able to detect errors early and use the model to automatically generate drawings and sections. Detecting errors early in the design stage made the drawing package more accurate, which will save money as the building is constructed.

5.10.3 Denver Art Museum Expansion

This project is an addition to the existing “Denver Art Museum” which is more than doubles the existing building. The steel skeleton structure covers 230,000 square feet of titanium shingles, and form a work of art in its own way. In addition, the 2,740-ton steel superstructure is an interwoven cluster of leaning braced frames and trusses. Thus, more

than 3,100 pieces of steel are included by 20 sloping planes that form the structure. The structure extends out 194-foot, 167 feet over and 100 feet above the avenue below. It is a true test to the power of BIM and integrated teamwork in which the design and construction of the building was made practical.

Using BIM techniques throughout this project allow for understanding the spatial relationships and detect conflicts ahead of actual construction. This approach enables “virtual construction” prior to the first workers arriving to the site and before fabricating the complex components of the structure. Moreover, during the design process, the architects created a coordination model that allowed 3D coordination of all participants. After defining the planes of each wall, a 3D wireframe model was developed and exported to structural analysis packages.

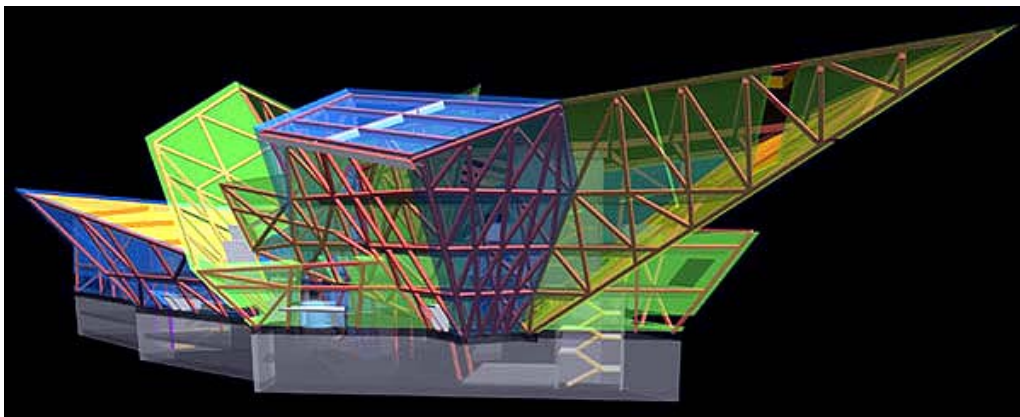

Fig 62: Computer generated image showing the steel frame (red)

Source: <http://www.designbuild-network.com/projects/dam/dam3.html>

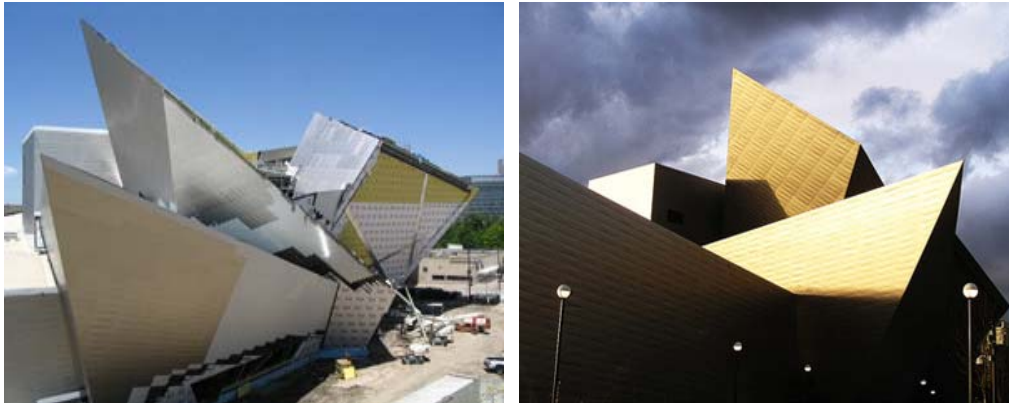

Fig 63: Addition to the existing Denver Art Museum

5.10.4 Park Hospital in Novi, Michigan

This project is a 500-square-foot, six story hospital that visibly established a relationship between the pastoral site, the scientific precision of modern medicine, and the human element of care giving. The size and complexity of the building shape, the integration of the new building with an existing building and the requirement of the location formed a great technical challenge for the design team. These challenges and obstacles were minimized using BIM techniques which yield many benefits during the design phase of the hospital. For example, adjustments and changes dealt with as the project progressed without impact on the designated schedule.



Fig 64: Park Hospital in Novi, Michigan

Source: [http:// www.nxtbook.com/nxtbooks/bemagazine/vol3issue4/](http://www.nxtbook.com/nxtbooks/bemagazine/vol3issue4/)

Additionally, the implementing of BIM throughout this project, the NBBJ (architecture and design firm) was able to use a single, common model that help the design team to clarify and understand relationship between all the building components and how they would interact with one another, as well as building interacting with the surrounding site.

BIM proves a valuable tool in which 10% of total cost and three months time were saved during the design phase of this project. Jonathan Wilch, principal at NBBJ [61], added that using BIM solution in this project has significantly reduced the hours spent on design, while improving the quality and the representations of the project. In addition, the design team were able to better understand the complexity of the design, and to broaden their work group to include engineers and outside consultants to resolve issues and produce an integrated and coordinated set of documents. Yet, this approach allows the design team to use cell component modelling which increases the efficiency when updating the design, especially for repetitive components. Moreover, the design team were able to analyze different value-engineering alternative to determine their impact on the project cost

and schedule. They were also able to carry out significant analysis of exterior material allocation, allowing for effective design decisions regarding material quantities and use of sustainable material. The model was also used to determine solar loads, allowing cooperative work with engineers to locate the building to better respond to the position of the sun for lighting. In fact, using BIM technique allows the design team of a large project to tackle the project in a more efficient way. The team members who each assigned to a particular task or element were working together on the same design, producing data directly from the digital model and output to a laser-cutting device and 3D printers. Throughout this project, designers were able to quickly produce updated, hard-copy documents as needed from the digital model. They were also able to exchange 3D models with their engineering consultants and construction partners more often and earlier in the process, which improve integration of the architectural and engineering information to avoid interferences and enable the constructors to visualize the project prior to construction.

5.11 Case Studies

Two case studies are provided by Azhar among others [66] to illustrate various tangible and intangible benefits yield using BIM for actual projects which are obtained from the Holder Construction Company, Atlanta, Georgia.

5.11.1 Hilton Aquarium, Atlanta, Georgia:

A hotel and parking structure project that scope is about \$46M in which BIM is employed to coordinate the design, detect clashes and arrange the work sequences. The BIM used in this project consist of the architectural, structural and MEP system as shown in figure (65). The BIM was developed during the design development phase using detail level information provided by subcontractor based on drawings from the designers.

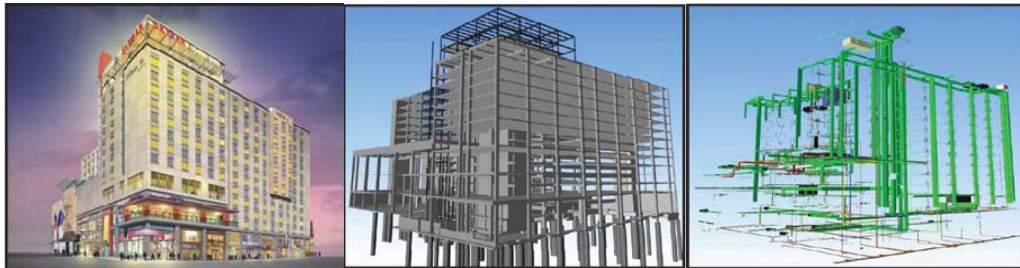

Fig 65: BIM consists of architectural, structural and MEP system

Source: [http://www.neduet.edu .pk/ICCIDC-I/Conference%20Proceedings/Papers/045.pdf](http://www.neduet.edu.pk/ICCIDC-I/Conference%20Proceedings/Papers/045.pdf)

The following benefits are achieved from this approach:-

- About 590 conflicts between structural and MEP components were identified and resolved prior to field installations. A saving of about \$200,000 in extras and avoiding months of delays were achieved.
- Improve design coordination.
- Eliminate of additional costs.
- Allow owner scope revisions without issuing change orders.
- Design changes were accommodated.

5.11.2 One Island East Project, Hong Kong:

This case study is to document the implementation of BIM to manage the functional and financial relationships between design, construction and facility management on a large, complex project by an owner-developer. The goal was to manage information more efficiently and save time and cost over the project life cycle. The seventy floors reinforced concrete and aluminum curtain wall skyscraper scope is about \$300M and completed in May 2008.

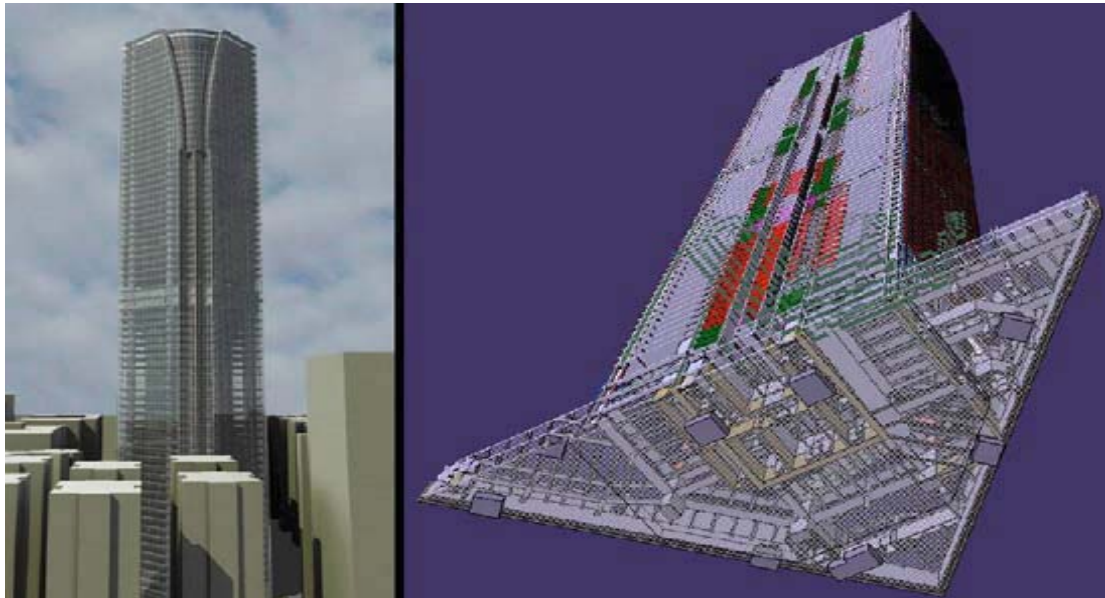

Fig 66: BIM of One Island East (OIE) Project

Source: <http://www.neduet.edu.pk/ICCIDC-I/Conference%20Proceedings/Papers/045.pdf>

However, using BIM throughout this project allow for managing all project coordination issues. In fact, over 2000 clashes and errors were identified prior to bidding and construction, which yield cost savings that would not be realized using a traditional 2D process.

5.12 Conclusion

This chapter has thoroughly explored Building Information Model (BIM) as a newly emerged technology which is being used by some the AEC industry in many projects. However, although many great potentials and benefits could be realized by BIM, the question is how and at what cost? In addition, there are several issues and obstacles that need to be addressed and tackled in order to ease and smooth the transactions from ordinary deliverable construction documents designs to a common BIM model. However, some of the major issues which obstruct BIM adaptations and endorsement industry wide are discussed as follows:

5.12.1 Who Owns BIM?

The shift from the historical deliverable construction documents to a BIM model has fuelled awareness in the design community over “who owns the final BIM?” If architects are not involved in the whole construction process, they fear their vision for a project can be compromised. Overall, there is a fear among designers and architects to be left behind in the BIM movement. Although generally aware of the BIM development, designers and architects are not actively driving the BIM movement [36]. According to Yoders [27], Scott Mackenzie said: architects are concerned if general contractors own the BIM, they will be left out. They fear that contractors will be selling the model to the client and just using architects as consultants merely to do the design task. In addition, designers fear about the potential misuse and theft of their digital intellectual property.

Yet, the issue of BIM ownership becomes even more complex when the final model is a collection of data from many models in which

many parties have contributed to it. Consequently, as the use of BIM grow more and more, certain standards will have to evolve to who is responsible for what and to what extent. An effort in this direction is lead by the National Institute of Building Sciences (NIBS) which is currently involve in developing standards to who is responsible for inputting what information into a model[70].

5.12.2 Work in a Multidisciplinary Coordination

All participant of a construction project should be taught multidisciplinary coordination of the project along with BIM software training, rather than simply teaching them how to design a 3-D environment. However, transition to BIM should be driven by architects, engineers, and other design professionals who would be working on a common model as a team [27]. In fact, this common model can be accessed for coordination or electronically interchange by all participants in CAD environment. Off course, because not all participants within a project have been educated in the same way, it is inevitable that will be conflicts between them. Therefore, teaching multidisciplinary coordination along with BIM to project's team is necessary to achieve collaborative process and joint decision-making.

5.12.3 Legal and Liabilities Issues

Although BIM primary aim is to allow for collaborative framework for design and construction, this new method of designing and constructing buildings is challenging the existing legal system and insurance structure that protects project participants. This is in fact blurring the line of responsibility among participants as integrated

practice continues to develop. This also raises the question concerning protecting each participant involve in the building process, as well as the intellectual property and confidentiality of information related [59]. AGC [70] argues that the existing legal environment is not able to cope with all risk management implications associated with the emergence of BIM as a tool that has dramatically changed design and construction process. The question is “what are the liabilities associated with participating and collaborating in the model? Although these issues are acknowledged, resolving them remains an open question. In fact, some fears that concern over liability, risk allocation, shifting and sharing associated with BIM may discourage many from experimenting with it.

Additionally, it has been reported at Applied Software’s Executive Roundtable on “Confronting the Challenges and Opportunities in Integrated Practice, collaborative Design and BIM”, that BIM is changing the standard method of design/bid/build process to a “shared project model”. Tony Smith, senior partner for Construction & Infrastructure Projects at Kilpatrick Stockton, LLP indicates that BIM is recognized as a new project delivery method and not an influence on traditional construction approaches, and among comes new risks, new rewards and new relationships. He also argues that seeking to fit this new BIM concept within the existing legal structure is similar to the old saying about trying to fit a square peg into a round hole. Legal experts agree that in order to reach BIM maximum goals and to support collaboration between parties while providing legal protection, industry standard contracts, insurance policies and surety bonds must be change to suite this new technology. Last year, two new standards form documents to facilitate the transmittance of digital data have been published by the American Institute of Architects (AIA) to allow for transmitting data in a digital working environment and maintaining control over its future use. The digital Data Licensing Agreement

(C106™-2007) and the Digital Data Protocol Exhibit (E201™-2007) to allow for sharing digital data between project participants in accordance with agreed-upon protocols form transmission, format, and use of the data [60]. The new AIA standards could smooth the transition to collaborative between parties by laying out conditions for digital data exchange among project participants; include all members from the owner to the mechanical subcontractor [59].

Indeed, while BIM offers improvement in the construction quality and efficiency, current business and contract models hamper the adoption of such collaborative teamwork. Experts believe business models and contract relationships must be rewritten to reward “best of” project decision-making and to distribute responsibility among all parties equitably, while providing adequate protection for the intellectual property and confidential information embedded in a BIM. Also, Richard Burroughs, president of Applied Software [59] add, BIM offer a better, more efficient and cheaper method to design and construct buildings but careful consideration must be given to the legal issues for it to extend beyond the early adopter phase into widespread us.

In addition, missing of legal and insurance protection to support a collaborative project delivery framework was reported by Hartmann and Fischer [36] in the “2007 AISC-ACCL eConstruction Roundtable Event Report” which hinder the vertical integration between participants involved in a construction project. Also reported is the lack of understanding of new technology by lawyers who blame the court decision to be focusing on the warranty of the rights of the individual stakeholders of a project and not focusing on a collaborative assessment. Indeed, lawyers need to keep up with current technological developments to understand the legal requirements of a BIM framework. In fact, insurers and lawyers are struggling with the new form of collaborative project delivery introduced by BIM technology;

they admitted to be behind the industry movement and need to keep up and clearly announced the need for help of other AEC participants to catch up. In addition, insurers are still hesitating to change their policies until better understanding and clear vision of the consequences of BIM implementation on AEC projects is achieved. Thus, they must be provided with case studies and other historical data for a better legal and financial understanding. Generally, the industry seems to be moving towards BIM without well defined legal or insurance policies at hand. However, firms who decided to wait until then might be left behind the fast technological developments.

Certainly, BIM and other similar technologies will eventually change the way project teams are typically interacting and so will the contractual language that defines them. However, this issue of uncertainties that associated with BIM should not hamper the embracing of this technology. With time, the typical tri-party approach to design and construction will be replaced by “Integrated Practice” and collaboration [70].

Moreover, Faulkner [12] concluded that digital does not always mean computable. For instance, a financial data can be created using word processors which include columns and rows of the numeric data. However, most of the numeric calculation and modifications must be done manually although the data is digital. On the other hand, the same financial data can be created in a spreadsheet version that contains numerical values, relationships and sophisticated calculations abilities although it looks identical to the word processor version. The data created in the spreadsheet is computable whereas the word processor representation is not, even though both look identical and digital. This is the case in the building industry for the most parts, which has adopted the word processor approach to documenting building designs for the past 20 years. Ordinary CAD tools are used widely to create

electronic drawings of buildings and this applies also to some 3D models which are little more than 3D drawings. Although the output of these systems are similar to the output of a BIM solution (just like the resemblances in our previous example between the financial data table in the word processor and the spreadsheet) it is not computable information.

However, the use of a single 'total' BIM on large projects, including all architectural, structural and services object information is still not available and may never be totally possible, due to the mass of information and subsequent data compression that will be required [81]. Currently most of these thoughts and wishes are exist only on paper. Through AEC professionals, participates and findings in literatures, many BIM systems that are achieved in the industry includes only two or three models, generally architecture and structural models and in some cases the MEP model. This is reflected in the coming chapter which aims to propose a BIM system to generate building abstractions such as plans, sections, elevation, details, and schedules.

6 A proposed BIM System

Considering Iran is one of the most earthquake endangered places in the world. Just, the Bam earthquake in 2003 destroyed the city in matters of minutes and killed more than 30,000 people [62]. This raises the necessity to construct earthquake resistance building to minimized damages and save lives. Therefore, a modern office building project is being design at the Berlin University of Technology (TUB) which aims to enhance earthquake resistance and energy consumption with respect to the climatic comfort of Iran. This is due to an early mentioned agreement between The Building and Housing Research Centre (BHRC) in Iran and TUB to enlarge and broaden their cooperation and establish collaboration on further academic and research related development activities.

Furthermore, the preceding chapter has discussed BIM technology in details including its uses and implementation within the AEC industry covering most common aspects and related issues. However, this chapter will present a practical example of a proposed BIM system using available data through the previously mentioned agreement. The system is to benefit from the availability of designing information of a proposed office building in Iran (2D plans) to propose a BIM system to generate building abstractions such as plans, sections, elevation, details, and schedules. Mainly, this chapter will use the available 2D plans to design 3D models of the office building to be used in developing the proposed BIM system. The final results and findings will be discussed throughout this chapter in more details.

6.1 System Architecture

Typically any BIM system (at least within the building industry) consists of several models (inputs) produced by different specialized individuals with different levels of details and different software tools [2]. Several 3D models could be included within a BIM system however; the followings are examples of the most commonly produced models as BIM system's inputs:

- Architectural Model (walls, floors, roof, circulation, special objects, etc.).
- Structural model (structural systems).
- MEP models (mechanical, electrical, plumbing).
- FP model (fire protection).
- Specialty models (equipment, finishes, temporary construction such as: scaffolding, form work, trenching, etc.).
- Site model (context-land, buildings, landscape, etc.).
- HVAC model (heating, ventilating, and air conditioning).

These models are possible components of the system input where as the output of the system will include extracted drawings, three-dimensional virtual models of buildings, evacuation plans, schedules, budget estimates, fabrication drawings, etc.

However, while BIM systems could include anything related to the building industry including facility life cycle and energy issues, this proposed BIM system consists of two 3D models of the architectural

and structural systems of the proposed office building (see system component section). Thus, these models were created during the design development phase using details obtained from the designers, utilizing Bentley's MicroStation software. Two segments of Bentley's MicroStation software (architectural and structural) are used to create the proposed system components. The first is used to produce the architectural model which consists of all 3D elements associated with it such as walls, floors, roofs, doors and windows, furniture, etc. However, the structural model is produced using Bentley's structural software which includes all structural elements and membranes. This is also going to affect the way data and reports are extracted and produced from the proposed system. This is mean, all architectural related data, drawings and quantity repots will be produced using MicroStation Architecture software; whereas fabrication, workshop drawings and steel lists and specifications are achieved using MicroStation Structural software. As a direct result, two separate databases for each application are produced along the way for each building system. Bentley's architecture database included all information need to produce drawings, sections, and bill of quantities for architectural model elements; and Bentley's structural database held data regarding steel membrane that form the building frame (columns, girders, bracing, etc.). This means, in order to get the right information and produce accurate media, the BIM model must be opened in the specific application. For example, to extract a shop drawing from the system, MicroStation Structural is utilized to open the 3D model using the associated database to perform the task.

Moreover, the functionality and usability of the proposed system will be the focus and discussion of this chapter. The discussion will explore the system in more details including: system components (system architecture), data extraction, as well as categorizing results of the

system by disciplines. In addition, findings and final results of the system will be explored and elaborated on as well as categorizing the end results according to types and disciplines will be illustrated.

6.2 System components

6.2.1 System Input

Two 3D models of the proposed office building are produced as inputs to form the proposed BIM system as follow:

6.2.1.1 Structural model

The structural model (Fig. 67) is created using Bentley's MicroStation TriForma Structural which contains all structural elements and members used in the building (footings, columns, girders, etc.) and will be used to produce information regarding structural detailing and documents. Thereby, it will be used to produce a variety of different types of structural construction drawings such as foundation plans, framing plans and detail drawings (elevation, sections, and details and many others).

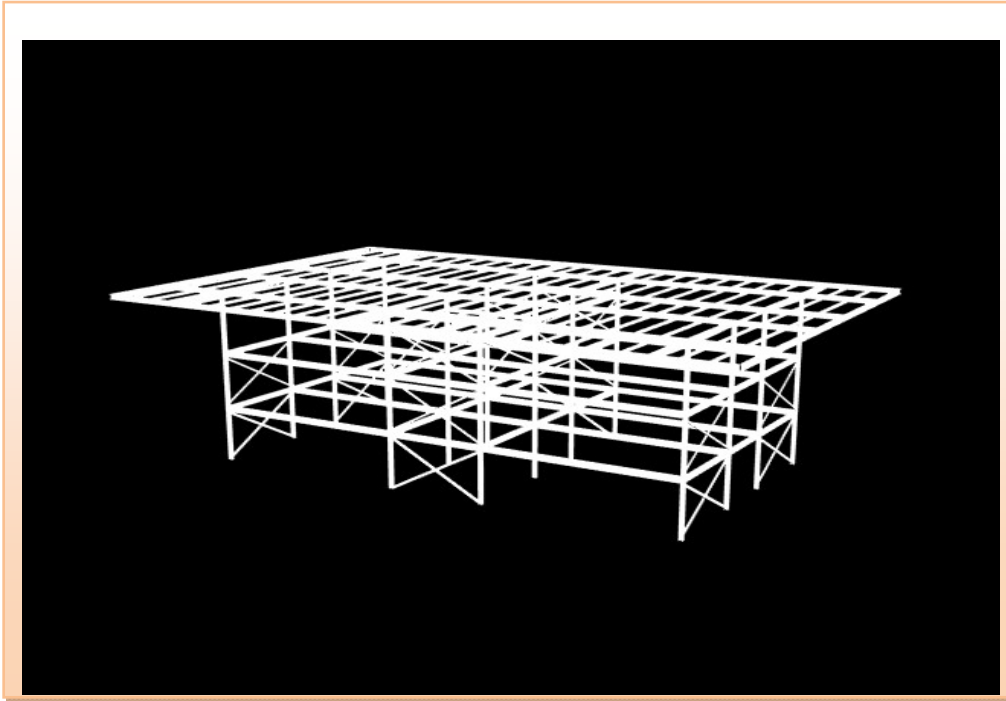

Fig 67: 3D structural model

6.2.1.2 Architectural model

The architectural model (Fig. 68) which is being used in forming the BIM system is created using Bentley's MicroStation TriForma Architecture solution. It includes all architectural elements forming the office building such as walls, frames, glass, floor, concrete, etc. This model will be used to produce any information related to architectural as needed. This includes drawings, schedules, and report extraction that occurs throughout the life cycle of the facility, and beyond.

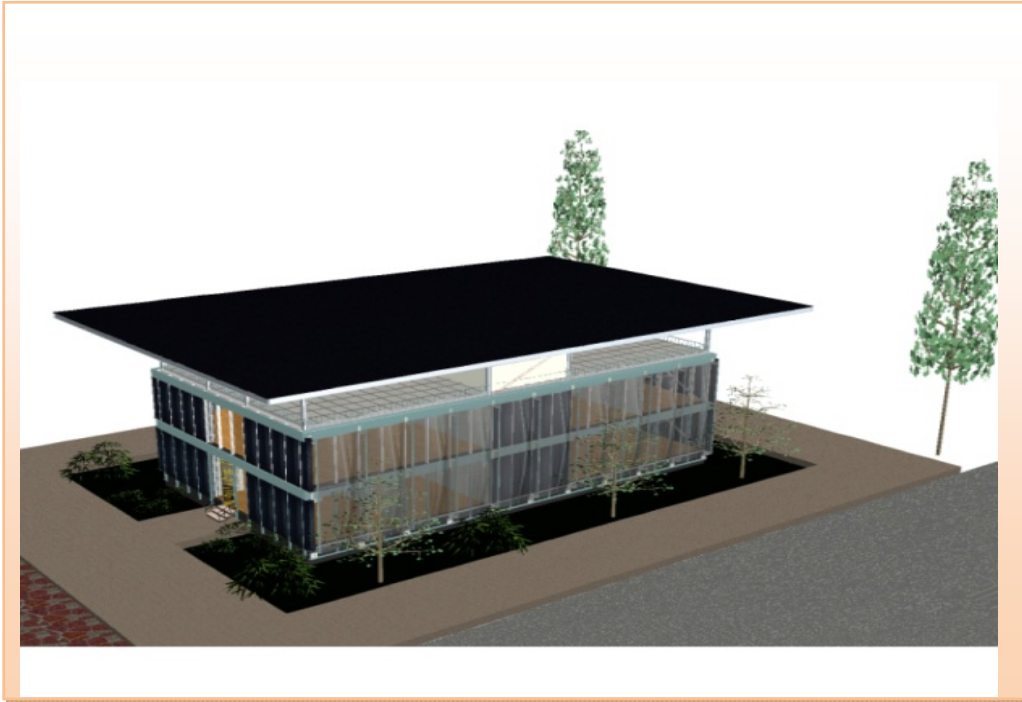

Fig 68: 3D architectural model

6.2.2 System Output

Once the two 3D models are combined to form the BIM system, different outputs (i.e. views and documents) are expected to be extracted from the system as illustrated by the proposed BIM System Chart in figure (69) which are:

6.2.2.1 Visualization

Different tools and means will be used to extract visualization data from the proposed BIM system such as rendered views, 3D visualization, animation, simulations and videos. This could be achieved using different tools such as on computer screens visualization, Google Earth tools or by Inserting the models into a “*.pdf” file which are explained in more details in the following sections.

6.2.2.2 Documentations

All kind of construction documents and detail specification associated with elements contained in the models are extractable from the BIM system, such as quantity analysis (architectural & structural reports), cost estimating, drawings and models, and reinforcement details and specification.

6.2.2.3 Drawings and Models

The proposed BIM system will be used to produce different architectural and engineers drawings as well as 3D models which will be illustrated further by the system.

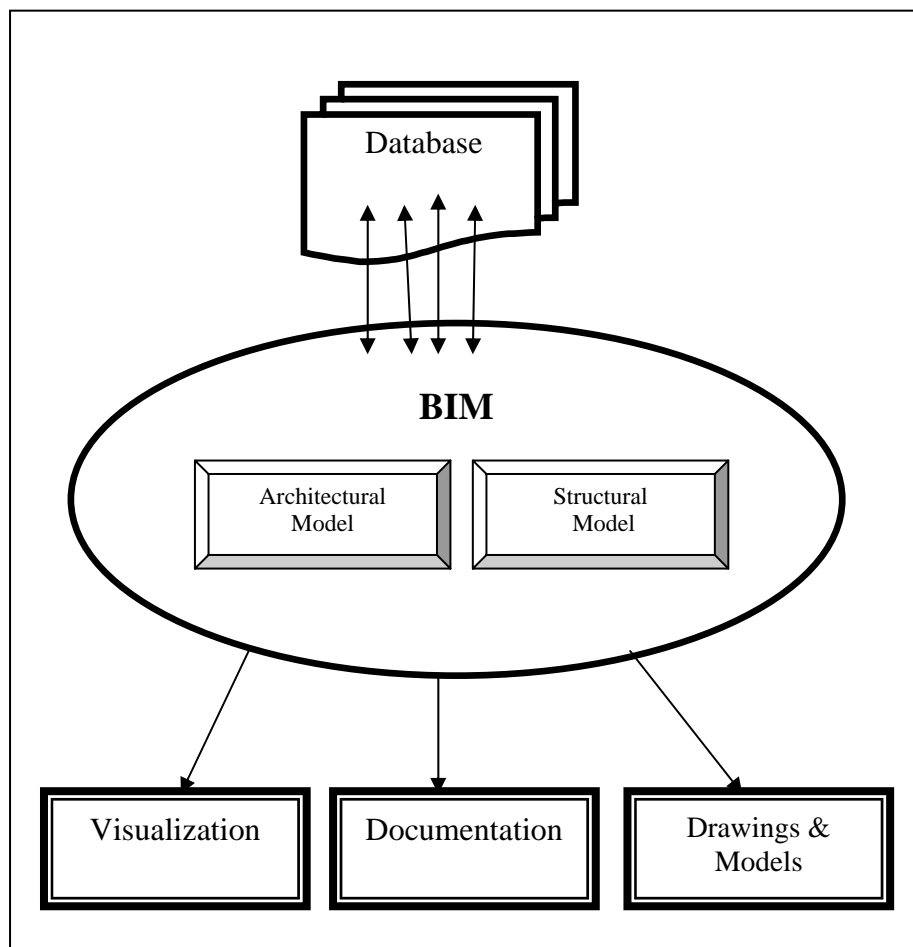

Fig 69: Proposed BIM system Chart

6.2.3 The proposed BIM System in Action

Once the office building design data is digitally captured in the 3D models and system is developed, several tools and methods are conducted to present the data as coordinated documents which will be shared across disciplines and serve as a centralized design management tool. However, extracting and producing views and documents from the proposed system are further illustrated as follows:

6.2.3.1 Extracting visualization from the BIM

Visualization has been an effective way to communicate between project participants in the building industry and has proven beyond doubt to be a vital aspect of 3D modeling if it's not the core aspect. It empowers designers and decision-makers to view their design and help them understand how the proposed building will function before actual construction started. This also allows detection of interferences and hindrance early in the design process and therefore, costly changes during construction are avoided. However, Kymmell [2] claimed that incorrect visualization of the project information is the largest problem when it comes to planning and construction. He argued, in order to correctly present the building project, it must be fully visualized, understood and communicated to avoid arising problems during construction.

Therefore, visualization evolved as essentially 3D tool to assist designers and decision-makers to better understand and study the facility in a real-like environment, saving time and avoiding inconsistency. Now a day's the industry is dominated by VR technology in which realistic photo-realism are generated and not only a still view.

However, the proposed BIM system is utilized to produce views, rendered pictures, documents and videos of the office building using chosen methods and tools as follows:

- 1.1. On Screen Visualization.
- 2.1. Google Earth Environment.
- 3.1. Inserting 3D model into a “*.pdf” file

6.2.3.1.1 On-Screen Visualization

Producing rendered views and photos of the office building is achieved using Bentley’s MicroStation architectural program. The proposed BIM system produces some photorealistic images and rendering of office building including adding desired textures and materials to improve visualization and provide earlier 3D visualization of the building, as shown in figure (70).

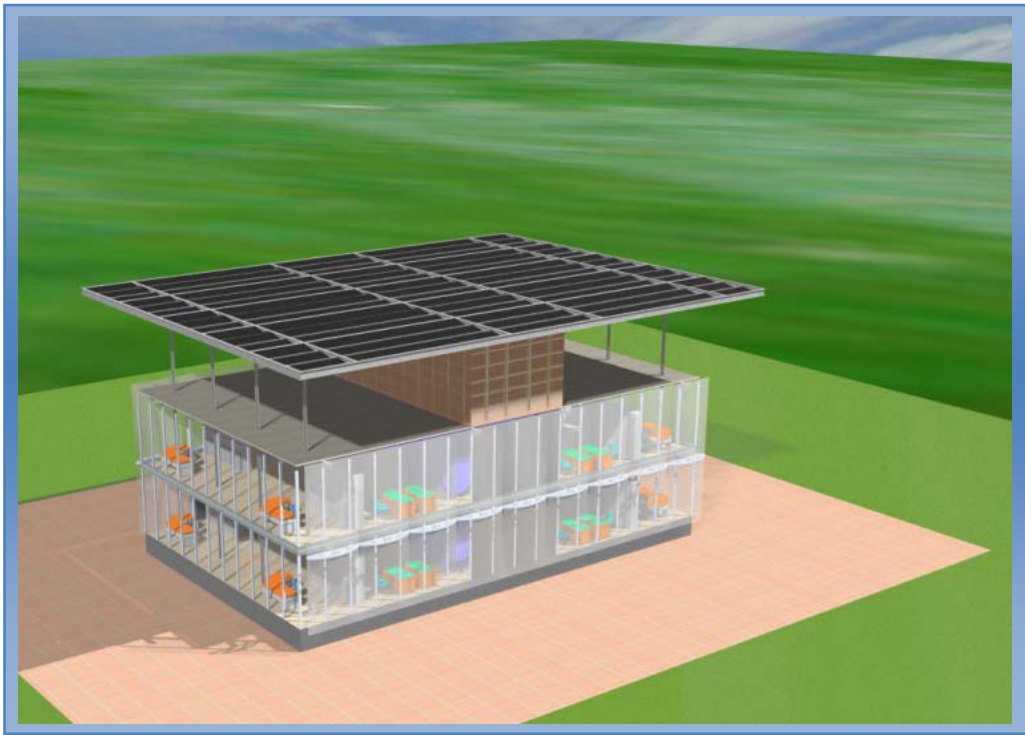



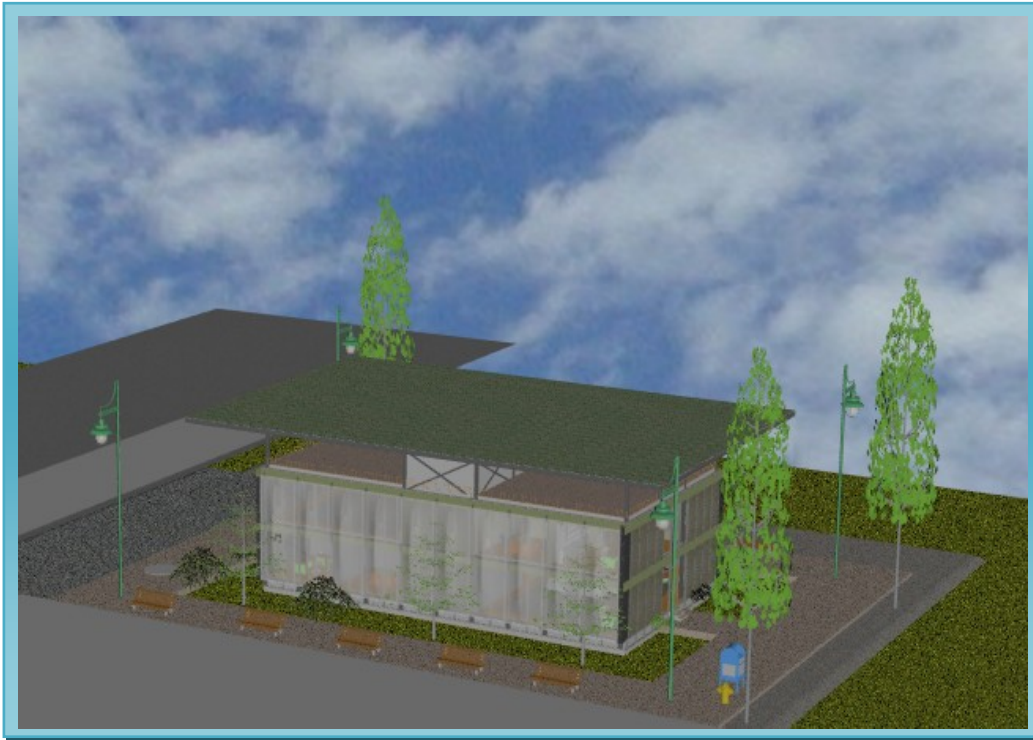

Fig 70: A sample of rendered photos produced by the BIM system

In addition, this system allows for walkthrough techniques allowing audience to view the project in a real-life like situation. This is achieved in Bentley's MicroStation Architectural, by specifying a defined path around the model whereby a fixed camera takes a series of shots automatically along this path and saves them as *.jpg files. These files (pictures) can be then loaded to MicroStation video maker to create a video to be viewed in MicroStation or can be saved in different format. For the purpose of this research, two types of visualization videos are produced, one illustrates the building as a wiremesh as shown in figure (71) and the second shows the building in ray trace rendered mode (figure 72). The program allow for the created videos to be saved in different format, however the produced videos are saved as Windows AVI (*.avi) files.

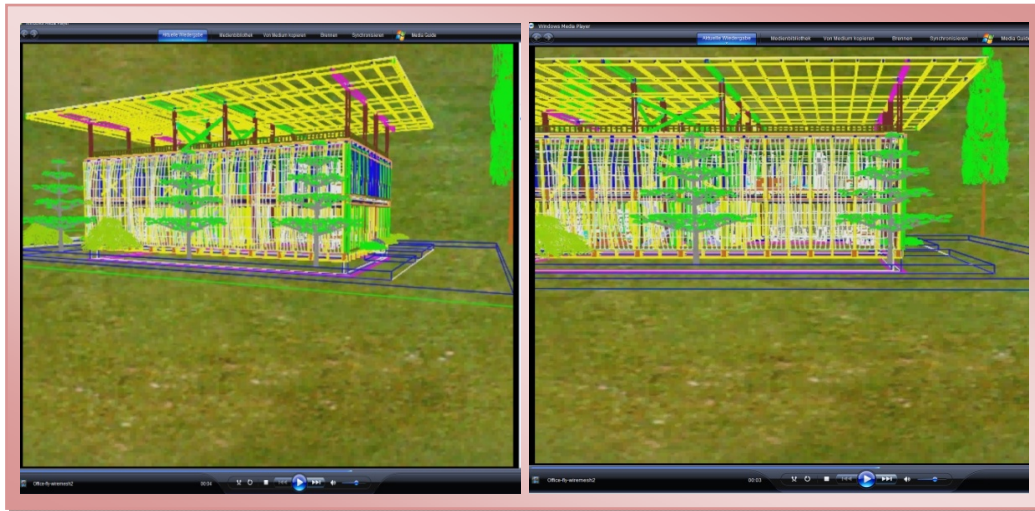

Fig 71: Screen shots of the “wiremesh-model” video

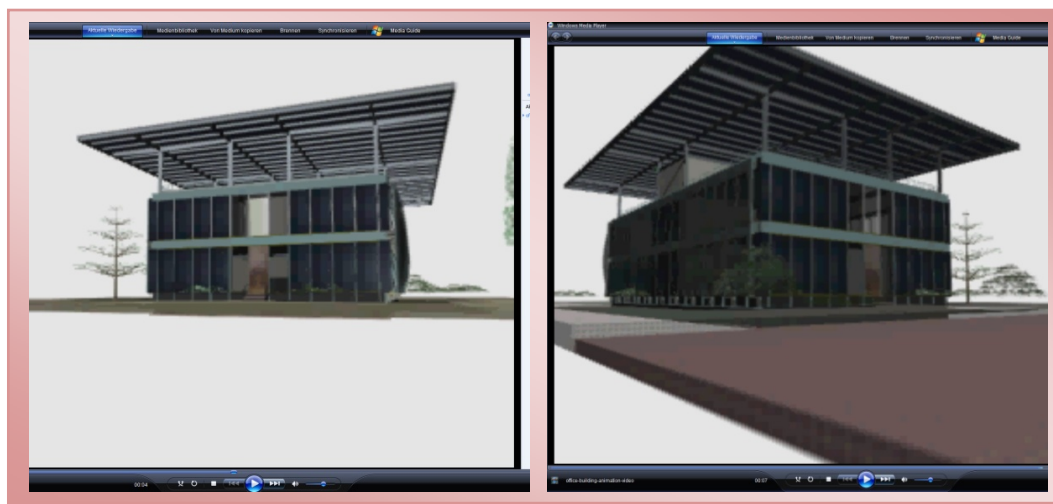

Fig 72: Screen shots of the “ray trace” video of the office building

6.2.3.1.2 Google Earth Tools

The second tool used to visualize the office building is Google Earth which was recently linked to MicroStation. Since the linking between MicroStation and Google earth, a new Google Earth setting tool was introduced by MicroStation to allow for exporting models to Google Earth environment. As mentioned earlier, the exported model will have all associated data exported with it, so it can be modified and viewed just as in its original program. However, Google Earth has been already used earlier in chapter 4 as a visualization tool for the VRCE. Additionally, the office building model has been also used there as an example of a detailed 3D model viewed by Google Earth. The process of exporting the model to Google earth and the results are further explained next.

6.2.3.1.2.1 Visualizing the BIM in Google Earth Environment

The process of exporting MicroStation's models to Google Earth (as illustrated in the help document of the program) typically includes:

1. In Google Earth, creating a placemark at the required location and save it as a "kml" file.
2. In the model, defining a monument point that matches the location of that placemark.
3. In the design model, exporting the model to a Google Earth "kml" or "kmz" file using the Google Earth setting tool "Export Google Earth (KML)".

Another alternative to exporting 3D models to Google Earth is to firstly export the model to COLLABorative Design Activity "Collada (.dae)" file and then add this model to a specific location in Google Earth.

However, unlike exporting the model directly from MicroStation, adding the model to Google Earth as a “Collada” file will not include any layers or saved views and only navigation is allowed in this case. In addition, models exported or added to Google Earth can only be rendered as smooth no more.

However, the following (figure 73) are some captured views of the office building model which was exported by the proposed system to Google Earth environment. While, there are considerable benefits viewing the model inside the Google Earth environment, there are also some drawbacks associated with this tool which are discussed earlier in chapter 4. However in general, the system allow for navigating the model as in its original program in addition to zooming in and out as required. It was also possible to switch layers of specific elements to reveal other hiding elements. So, one could explore the model with most visualization options enabled within the rich texture of Google Earth Environment.

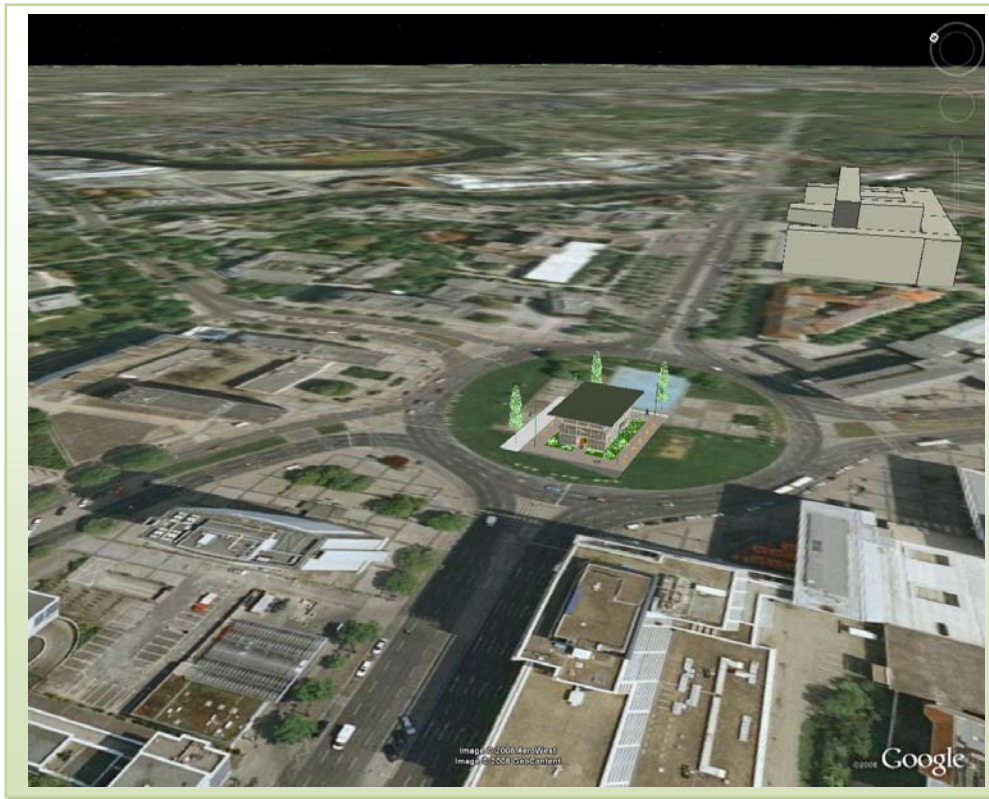

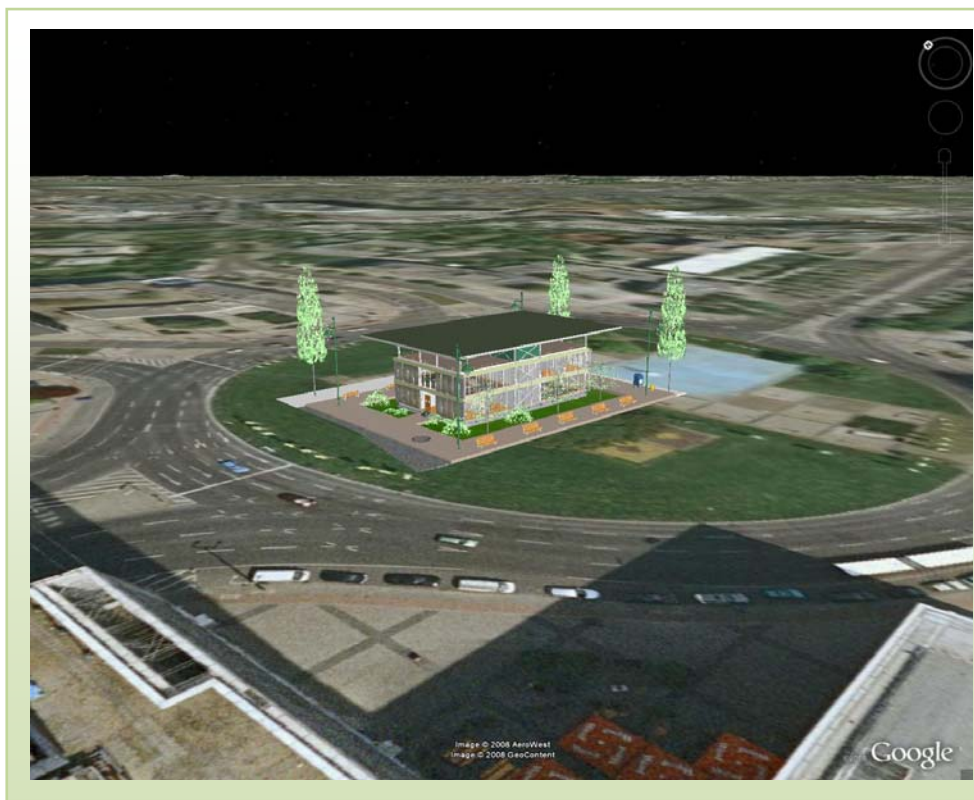

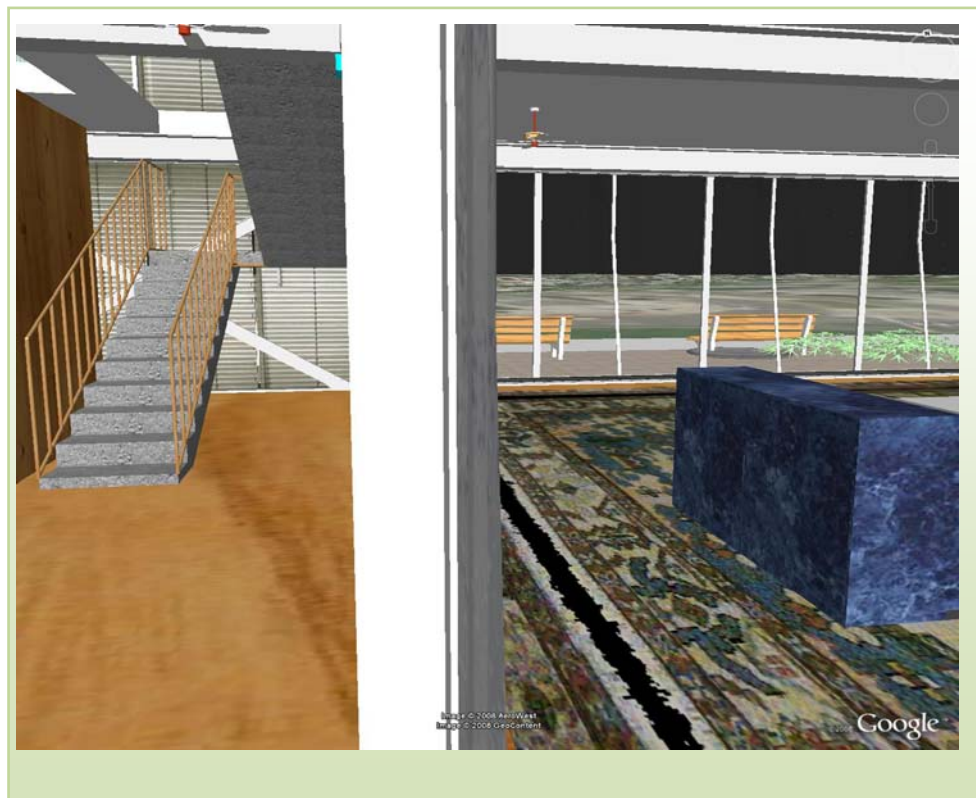

Fig 73: Views of the office model in Google Earth environment

6.2.3.1.3 3D Model in PDF Files (PDF Images)

Thirdly, Adobe® Reader® is counted for the third tools used as visualizing method of the BIM model. Starting from Adobe® Reader® 7.0 and higher supports the insertion of 3D content within PDF documents is allowed. This new technology enables publishing of 3D visualization, designs, models and data, utilizing the free Adobe® PDF Reader.

However, to embed 3D content within PDF documents, MicroStation Uses “Universal 3D” (U3D) format which was introduced by the 3D Industry Forum (<http://www.3dif.org>) as means for transferring three-dimensional data from CAD systems to mainstream applications, to export geometry directly to U3D or to seamlessly create PDF documents with embedded U3D objects. Bentley was one of the few companies that supported U3D and therefore, all Bentley applications can automatically be converted into PDF files [56].

This enable CAD users to create PDF documents of their design including 3D content that contain any visualization data and settings that exist within the design file, such as lights, materials, texture map, and animation or flythrough in addition to saved views [57].

However, in MicroStation, the procedure of creating PDF documents with 3D content is similar to printing a standard 2D document. When printing, the user enables the Plot to 3D settings in the print dialog box and chooses “Bentley driver”.

6.2.3.1.3.1 Inserting BIM into a PDF document

The BIM model will be exported as a PDF file including all visualization data that associated with it. Once opened in Adobe® Reader®, the user can navigate and interact with the BIM similar to original program. For example, all levels, references, animation, and saved views are conveyed with the model and they will react in the same way as in original program. This enable users to switch desire levels or lights on or off and select the preferred saved view as required. They can also, rotate, zoom, select and explore to reveal hidden information, all in the context of a PDF file. In addition, Adobe® Reader's users can add their own views to the model and saved them as they like. This technique makes practical distributing and interactive of 3D models to everyone with the free Adobe® Reader possible which take up less space on computer's hard drive.

However, the proposed BIM system has inserted the office building model into a "pdf" which acted similarly to its original program including saved animation. It was possible to switch layers and lights on or off, rotate and zoom around the model and explore information just as a CAD program in addition to the saved animation which functioned automatically within Adobe®. Some screen shots of the inserted model are provided by figure (74).

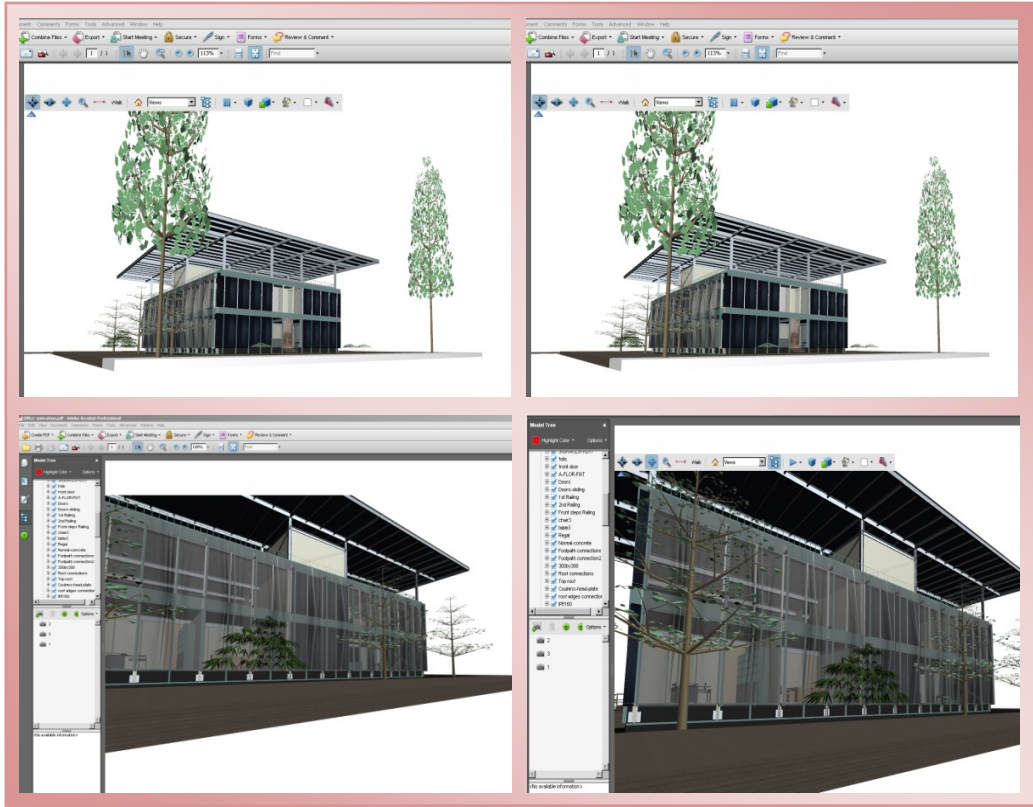

Fig 74: The BIM is inserted in Acrobat as “pdf” file

6.2.3.1.3.2 Advantages and disadvantages of 3D plot in PDF

Adobe PDF animations is the ideal format for sharing walkthroughs and flyovers, making proposals for review, or exchanging and communicating construction sequencing [58]. The ability to export the complete 3D model as a PDF file has many advantages, such as:-

1. Adobe® Reader® is free and easy to use.
2. Convey complex 3D designs to all project participants or clients no matter what tools they use.
3. Export photorealistic renderings or shaded 3D models directly from MicroStation.

4. Visualization data and setting such as lights, materials, texture map, and animation are carried on to the PDF file.
5. Saved views, references and levels are also included within the PDF file and function similar to original software.
6. Some MicroStation users realized benefits of 3D PDF in the following:-
 - Using 3D PDF to demonstrate design intent in their proposals.
 - Communicate project progress in their newsletters using 3D in PDF.
 - Using 3D in PDF to visualize multiple stages in the construction process.
 - Including 3D in PDF as an effective teaching aid in their training manuals.

However as in the case of many techniques and tools, inserting 3D models into Adobe® Reader® to visualize BIM has some draw backs such as:-

1. Plotting a 3D model in PDF with animation required a great deal of computer memory otherwise; this could be a time consuming process.
2. Only activated levels in the original model at the time of plotting will be conveyed with the model.
3. Visualization is limited to the outside of the model (flythrough), whereas in other techniques such as Google Earth one can go deep inside the model and perform a walkthrough.
4. Adobe® Reader® PDF animations do not offer any rich geographic imagery or surrounding that imitates reality like in Google Earth.

6.2.3.2 Extracting Documents from the BIM

BIM provides the greatest opportunity for improvement in construction documents since CAD. It automates material take-off to aid design verification and material procurement [30]. It is also considered as the building industry's application of product information modeling concept, where the product is a building. However, its Implementations used to be very "geometry centric", but now a day's BIM is expanded to include properties for use in analysis applications like energy use simulation, quantity take-off, cost estimating, construction planning and many types of engineering analysis [15].

In addition, digital models enable designer to examine different scenarios and answer 'what if questions'; for example, what if we replace the tiles with wood? Or what happens to the cost if we increased the height of the ceiling? Nowadays, designers are answering these questions in a matter of minutes or hours where it used to take days and weeks to answer them. Although, three-dimensional computer generated models have been used since the 1970's and designers have long used 3D representation as part of their analysis and communication processes, in most conventional software systems, these 3D models are created and maintained separately from 2D representation and thus requiring manual coordination between the 3D representation and the 2D contract documents or construction drawings. In this case, it is the designer's responsibility to make sure that changes are incorporated to maintain consistency. However in digital models, the 2D and 3D representation come from the same source (database), so consistency is ensured. Digital models also simplify the generation of 2D reports by slicing the model; designers can easily generate floor plans, sections, elevations etc. Effectively, these intelligent models may be assembled by the design team object

by object, system by system, in a digital environment. This will not only offer designers 3D visualization at any time during the design process, but also enable them to extract, almost instantly, much richer information and documentation than they could get from 2D drawings. Additionally, integrated digital models give designers instant access to relatively complex design information such as area calculations which is a task performed several times during the course of sorting out a building program. Subsequently, a digital model should allow the design team to derive and update area calculation results effortlessly whenever the design changed or modified. Likewise, cost information should be quickly generated by attaching to any object the cost unit. This can count or measure the objects and insert them in a schedule, providing quick access to cost information whenever a change is made [28].

However, the proposed BIM system has produced documents and quantities reports as follows:-

6.2.3.2.1 Quantity take-off (Quantity Estimates)

Quantity take-off is the process of measuring the amount of something in the project model (concrete, glass, wood, doors, windows, etc.) and usually combining it with other information to produce a list of quantities in a spreadsheet or database format. In fact, the quantities of the various materials in the model can be extracted by the physical information inherent in the model components [2]. Significant benefits could be realized when producing quantity take-off based on information contained within a single model, in addition to producing the quantity report of a building automatically which can be very time-consuming process when done from a traditional set of drawings and specification.

However, the proposed BIM system produces quantity reports using Bentley's MicroStation TriForma (architectural and structural). The process of producing these reports by MicroStation requires each item in the 3D model to have three elements (Part, component and formula) in order to generate accurate quantity take-off of the proposed building. In MicroStation, prior to modeling, during modeling or after modeling the building, parts and components are created for each item that will be placed in the model. The components are attached to each part (item) and a formula is entered that will determine how the part (item) will be measured for each component. For example, the formula for concrete will measure the volume whereas; the formula for a wall will measure the square area of that wall. All model elements are intelligent and given a name when created (part) in which is attached to project information. Further information regarding building materials, unit costs and specifications are attached to that part through a component. Parts and components are also applied in the process of extracting presentation drawings and reports, which control the final presentation by determining for example, the line color and thickness, hatching of sections, and other drawing symbols, etc.

This enables designers and users to generate reports about their design in a matter of minutes. Also, the parametric model allows for reporting any element contained in the BIM. Reports are generated as often as necessary, counting elements by numbers, square or cubic meters, etc. The report also includes unit prices, sub totals for each item, and a grand total for cost.

However, the quantity reports produced from the proposed BIM system are divided into two segments: 1) architectural quantity report, and 2) structural quantity report. This due to system architecture discussed earlier which includes architectural database and structural database, thereby separate quantities reports are generated as follow:

1. Architectural Quantity Reports

Producing an architectural quantity report directly from the BIM system involves setting the quantified levels (location of the elements) and the report as specified by MicroStation Architecture. Then, the quantity report extracted from the BIM system is sent automatically to an “Excel” file where modifications and improvements are further achieved. Depending on the extraction layout, the architectural report produced by the proposed BIM system includes two sections:

Detailed report

The “architectural detail report” extracted from the BIM system produces a complete list of all elements included in the model which are attached to part, components and valid formula. The list of elements provided in this “detailed report” are specified and arranged by the user in MicroStation (figure 75); thereby the user selects the elements that needed to be included in the quantity, defines their ranking order and specifies data to be associated with each element (i.e. length, weight, price, etc.). Also, the user chooses whether or not to have a grand total for similar elements (such as glass, wood, concrete, plastic, etc.) contained in the quantity report.

The resulting quantity report is sent to an “Excel” file where the user can further modified the presentation or round-off numbers and totals. In addition, the final report could be converted to a “*.pdf” file which is an option offered by “Excel”.

Item ID	Description	Material	Quantity
644	foil frame	209817 B2020 Aluminium Foils frame straight	1 pc
645	foil frame	209825 B2020 Aluminium Foils frame straight	1 pc
646	foil frame	209833 B2020 Aluminium Foils frame straight	1 pc
647	foil frame	209841 B2020 Aluminium Foils frame straight	1 pc
648	foil frame	209849 B2020 Aluminium Foils frame straight	1 pc
649	foil frame	209857 B2020 Aluminium Foils frame straight	1 pc
650	foil frame	209865 B2020 Aluminium Foils frame straight	1 pc
651	foil frame	209873 B2020 Aluminium Foils frame straight	1 pc
652			22 pc
653			
654	foil frame	209895 B2020 Aluminium Foils frame curved	1 pc
655	foil frame	210311 B2020 Aluminium Foils frame curved	1 pc
656	foil frame	210324 B2020 Aluminium Foils frame curved	1 pc
657	foil frame	210335 B2020 Aluminium Foils frame curved	1 pc
658	foil frame	210346 B2020 Aluminium Foils frame curved	1 pc
659	foil frame	210357 B2020 Aluminium Foils frame curved	1 pc
660	foil frame	210368 B2020 Aluminium Foils frame curved	1 pc
661	foil frame	210379 B2020 Aluminium Foils frame curved	1 pc
662	foil frame	210390 B2020 Aluminium Foils frame curved	1 pc
663	foil frame	210401 B2020 Aluminium Foils frame curved	1 pc
664	foil frame	210412 B2020 Aluminium Foils frame curved	1 pc
665	foil frame	210425 B2020 Aluminium Foils frame curved	1 pc
666	foil frame	210436 B2020 Aluminium Foils frame curved	1 pc
667	foil frame	210447 B2020 Aluminium Foils frame curved	1 pc
668	foil frame	210458 B2020 Aluminium Foils frame curved	1 pc
669	foil frame	210469 B2020 Aluminium Foils frame curved	1 pc
670	foil frame	210480 B2020 Aluminium Foils frame curved	1 pc
671	foil frame	210491 B2020 Aluminium Foils frame curved	1 pc
672	foil frame	210502 B2020 Aluminium Foils frame curved	1 pc
673	foil frame	210513 B2020 Aluminium Foils frame curved	1 pc
674			20 pc
675			
676	foils	212180 B2020 Foils EFEP Foils	17,613 m2
677	foils	212352 B2020 Foils EFEP Foils	17,613 m2
678	foils	212367 B2020 Foils EFEP Foils	17,613 m2
679	foils	212382 B2020 Foils EFEP Foils	17,613 m2
680	foils	212397 B2020 Foils EFEP Foils	17,613 m2
681	foils	212412 B2020 Foils EFEP Foils	17,613 m2
682	foils	212427 B2020 Foils EFEP Foils	17,613 m2
683	foils	212442 B2020 Foils EFEP Foils	17,613 m2
684	foils	212457 B2020 Foils EFEP Foils	17,613 m2
685	foils	212472 B2020 Foils EFEP Foils	17,613 m2
686	foils	212487 B2020 Foils EFEP Foils	17,613 m2
687	foils	212502 B2020 Foils EFEP Foils	17,613 m2

Fig 75: Portion of the “architectural detailed report”

Summarized report

The summarized quantity report extracted from the BIM system is specified by the user in MicroStation when setting the field to produce the report. It is part of the “architectural quantity report”, which is provided by “excel” options (figure 76). This report represents the grand total quantity of elements contained in the “architectural detail report”.

	A	B	C	D	E	F	G
1	Fam.	Component	Description	Quantity	Unit	Unit Price	Total
2	Areas	Area		679,889	m2	1	680
3	Units [office building]	Length	steel foot path between fassads	100	m	0	0
4	Units [office building]	Type 01	foot path holders assembly	66	pc	0	0
5	Units [office building]	Type 02	full glazing single doors	10	pc	0	0
6	Units [office building]	Type 03	Glazing double sliding doors	8	pc	0	0
7	Units [office building]	Type 05	toilet Partition-Stainless Steel	140,484	m2	0	0
8	Units [office building]	Type 06	Isolation	147,065	m3	0	0
9	Units [office building]	Type 07	Pre-caste concrete	123,638	m3	0	0
10	Units [office building]	Type 08	Normal concrete	34,27	m3	0	0
11	Units [office building]	Type 10	Reinforced concrete	141,923	m3	0	0
12	Units [office building]	Type 11	Wood exterior doors	2	pc	0	0
13	Units [office building]	Type 12	interior walls partitions	312,876	m2	0	0
14	Units [office building]	Type 13	EFEP foils	334,647	m2	0	0
15	Units [office building]	Type 14	Exterior Aluminum	649,144	m2	0	0
16	Units [office building]	Type 15	Screed	671,385	m2	0	0
17	Units [office building]	Type 16	tiles	336,217	m2	0	0
18	Units [office building]	Type 17	Foils frame straight	22	pc	0	0
19	Units [office building]	Type 18	Foils frame corved	20	pc	0	0
20	Units [office building]	Type 19	Aluminum frame	127	pc	0	0
21	Units [office building]	Type 20	Horiz alum. frame	6	pc	0	0
22	Units [office building]	Type 21	Exterior galss	649,616	m2	0	0
23	Units [office building]	Type 22	3m Wall posts	133	pc	0	0
24	Volume	Volume	total voulme (L*W*H)	32,33	m3	0	0
					Grand Total		680

Fig 76: Architectural Summarized quantity report

Grouped quantity report

This is produced directly from the proposed BIM system by given identical elements similar component names. For example, all concrete elements are given the same component name (Type 03) and all “vertical aluminum frame” used in this model have the component name (Type 01) in order to have a final total of these elements together. Once the report exported to “Excel”, all similar elements will be shown together with a grand total however, some modifications are required to establish the “grouped quantity report” as shown in figure (77), this including emphasizing group’s

2. Structural Quantity Reports

The proposed BIM system produces the structural report using “MicroStation TriForma Structural”, and it also consists of detailed, summarized and grouped reports.

While both architectural and structural quantity reports extracted from the proposed BIM system are sent directly to “Excel”, the structural report is achieved differently which is produced using already define elements. In this case, the desired structural elements (i.e. beams, columns, girders, etc.) are selected (highlighted) in their original program (TriForma Structural) and using “report commands” allowed by the program, the elements are exported and the results could be viewed in “Excel”. However, unlike “TriForma Architecture”, here the structural elements are chosen from a wide variety of elements that offered by program’s database, which means that these elements are already defined and known by the program. Thereby, “TriForma Structural” includes an “STR Spreadsheets” tool box which allows for creating a Microsoft Excel spreadsheet that is populated with data from the structural model. The STR Report Spreadsheet contains macros that seek through the 3D model and generate the material and quantity of the structural elements in an EXL spread sheet. Then the structural quantity report which is exported to an EXL file format can be modified and altered just as an ordinary spreadsheet. Interestingly, as illustrated by figure (78) which shows a portion of the structural report, there are two distinct columns of data are shown there (yellow and white). This means, the data in the white columns are editable while data in the yellow columns cannot be edited because it represents data that are measured directly from the model or calculated using the model data.

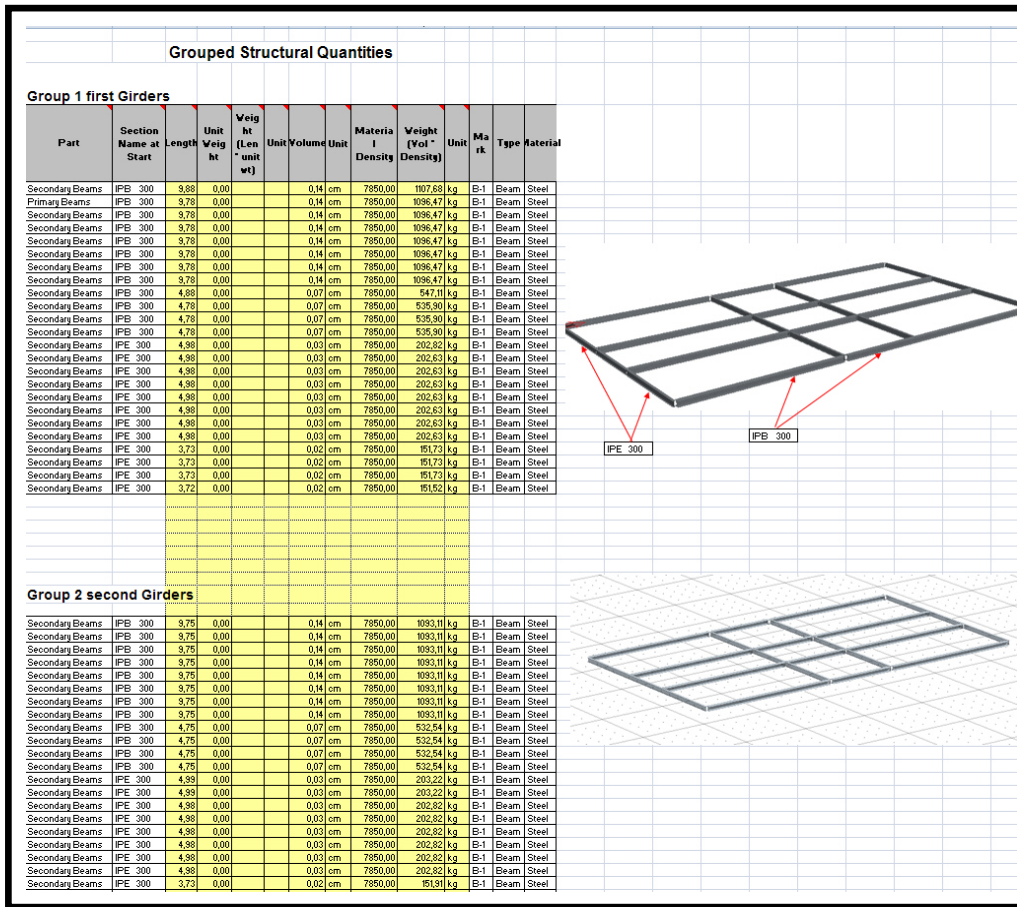

Fig 79: Developed “grouped structural quantity report”

6.2.3.2.2 Reinforcement Details and Specifications

Bentley [42] indicates that in addition to automatically extracted architectural and structural quantity reports, BIM empowers structural engineers and designers to:

- Develop structural systems for their building with unlimited freedom.

- Investigate and study more design options in order to make better design decisions.
- Predict construction costs and building performance prior to actual construction.

However, the proposed BIM system contains no details or specification within the developed two 3D models (system input) and therefore no data or specification were extracted from the proposed system.

6.2.3.3 Drawings and Models

It has become evident that designers and architects can benefit from BIM techniques in terms of drawings production, data storage and drawings updating. For example, BIM enables a better storage of all design data within a 3D model of a facility in which 2D plans and drawings can be automatically generated from this model, including details and sections. Designers can integrate changes in their design easily, while drawings and details are updated automatically ensuring consistency and accuracy of produced drawings and details [36].

Additionally, BIM systems enable designers to focus on their design by developing 3D models from which presentation drawings and data reports are easily extracted. Thus, the proposed BIM system produces architectural and structural drawings, sections and details as required. However, just as discussed earlier when producing quantity reports, drawings and models are also produce from two sources (TriForma architecture and structural), depending on the type of required details. “MicroStation TriForma Architecture” is responsible for generating architecture drawings from the system such as section cuts using “Drawing Extraction Manager” utility, whereas “Triforma Structural” is responsible for generating all steel drawings, sections and details.

Extracting and producing drawings and models from the proposed BIM system are explained below.

6.2.3.3.1 Architectural Drawings

The process of generating architecture drawings from the system using “MicroStation TriForma Architecture”, involves the following:-

- defining the “section cutting planes” and
- forward and reflected views and
- the extracted information is processed, resymbolized, and written to a new drawing.

However, the “section plane” is separate and different from the “forward view plane” and it resymbolized independently from the forward view planes in drawing extracting. For example, a section cut of a plan view through a wall looking downward will usually show that wall in the cut plan while elements such as door swings are shown in the forward view because the section did not cut through them. In addition, the extraction of drawings from the BIM required very complex rules for resymbolization to be applied based on part information (i.e. the appearance of the element can be determined by the part name of the component). Such things like element thickness or hatching are controlled by the part’s name of that element as illustrated in figures (80&81).



Fig 80: Architectural produced floor plan and details

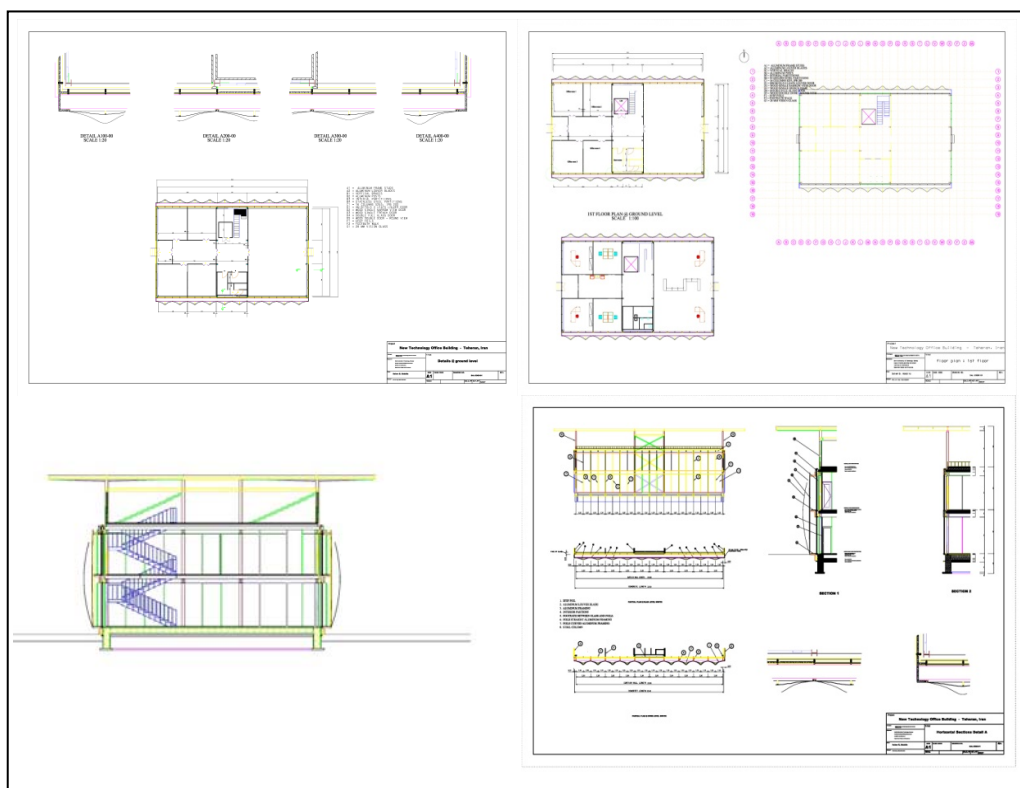

Fig 81: Architectural produced drawings (sections & details)

6.2.3.3.2 Structural Drawings

Bentley Structural produces a variety of different types of structural construction drawings such as foundation plans, framing plans, elevations, sections, and details, etc. Extracting structural drawings from the BIM system by “MicroStation Structural” is achieved using the “Drawing Extraction Manager” tool. There the user defines what levels of a design file to process into a drawing, or define a cut or forward view distance to show just a specific cross-section of the design.

However, the structural drawings produced by the proposed BIM system are controlled by “Bentley Structural” rules which are established using the “Drawing Resymbolization Rules Manager” and the “Edit Drawing Resymbolization Rule” dialog boxes. These rules tell the software how to process the structural data in the extracted drawings and how or if the structures are labeled. All preferences (how it is viewed, how the members are drawn, which members appeared in the drawing) are controlled by the structural rules so a user can go back and produce the same drawing without having to redefine all the criteria and settings. For example, beams that are behind another beam are set by the rules to appear as hidden lines.

6.2.3.3.2.1 Reinforcement Drawings

The BIM system produces an overhead view of the steel section and vertical detailing sections that include labels for the columns, beams and girders as shown in figures (82 to 84).

However, these are only a few samples of the variety of drawings the BIM system is capable of. Though, the BIM system produces drawings as required full automatically, given the user total freedom in

choosing the desire preferences such as color of elements, text appearance or overall section presentation.

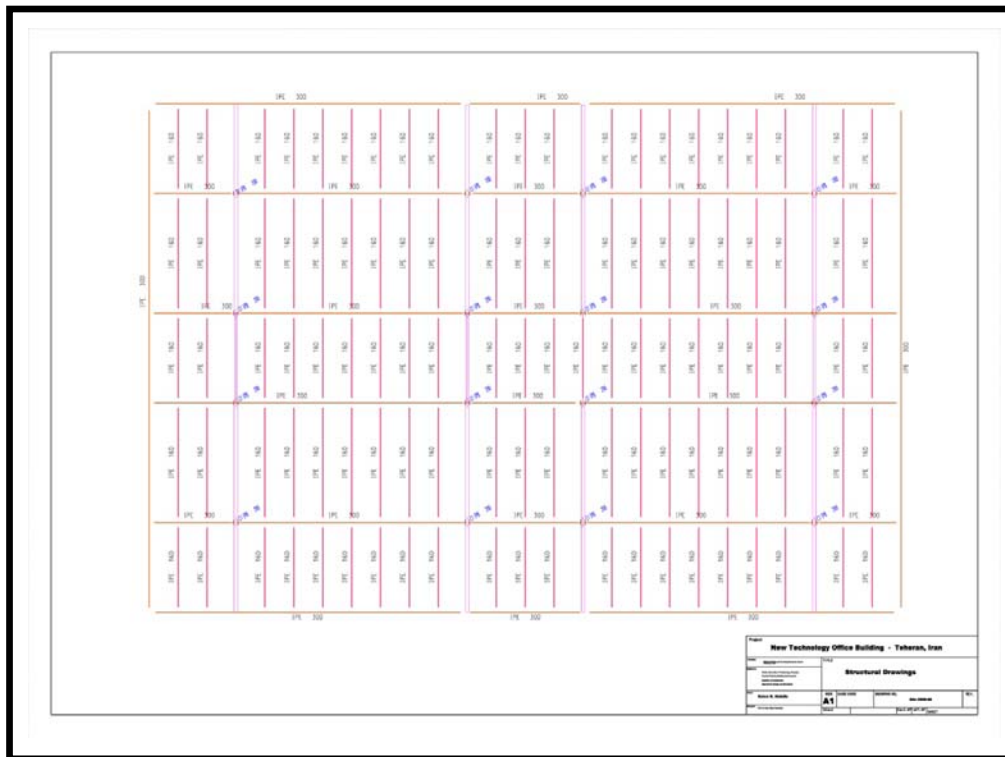

Fig 82: Top steel detailing view

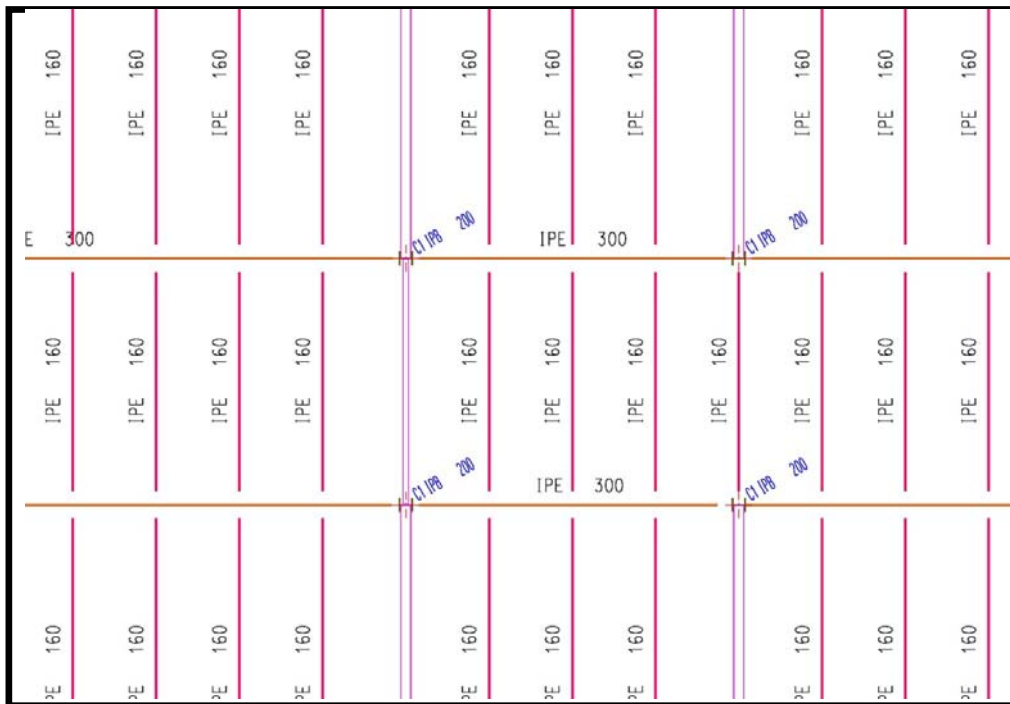

Fig 83: Portion of top steel detailing view produced by BIM

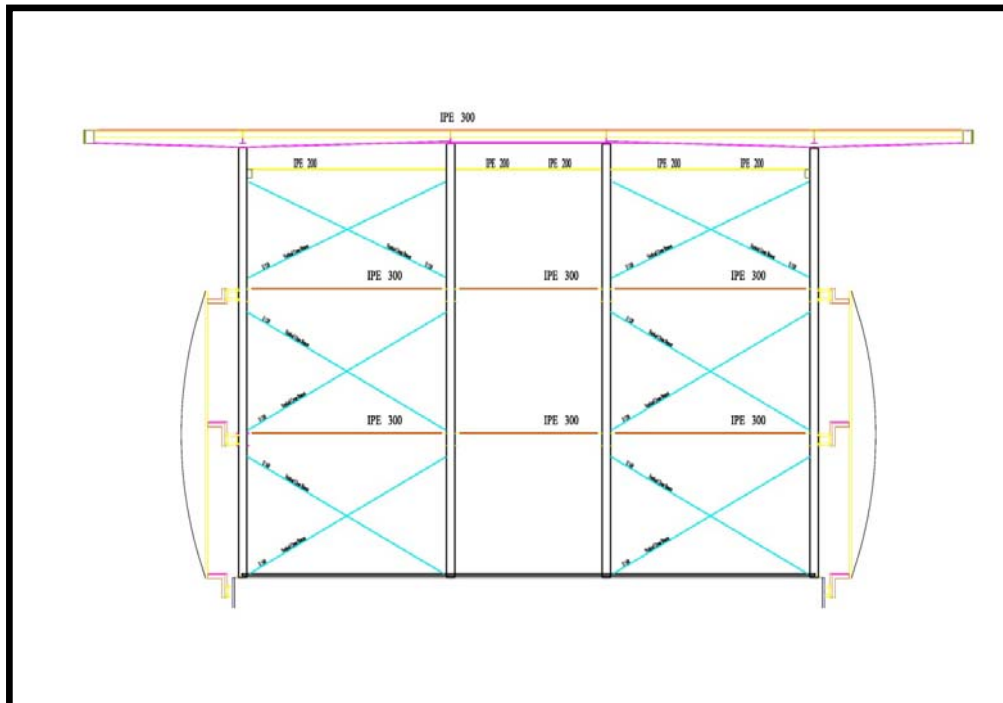

Fig 84: A vertical section generated from the BIM

6.2.3.3.3 3D Models

3D model presentation is the core of BIM techniques, because visually rich 3D views are direct presentations of the underlying building information. In addition, 3D models allow for better understanding and visually comprehending by viewing several different views of a design from different angles in a very short time. In fact, older presentation techniques (usually based on drawings) could not possibly provide such an exhibition as readily or as effectively. Also, 3D models give designers and clients the feel of actually walking around a new building and experiencing a humanistic observation by looking at the building while standing in front of it.

In this matter, the proposed BIM system offers several 3D models techniques and tool. However, models can be extracted directly from the system in MicroStation or combined with Adobe Acrobat, the proposed BIM system is capable of generating different types of 3D models for illustrations and visualization as shown in figure (85) which are produced as “*.pdf” files.

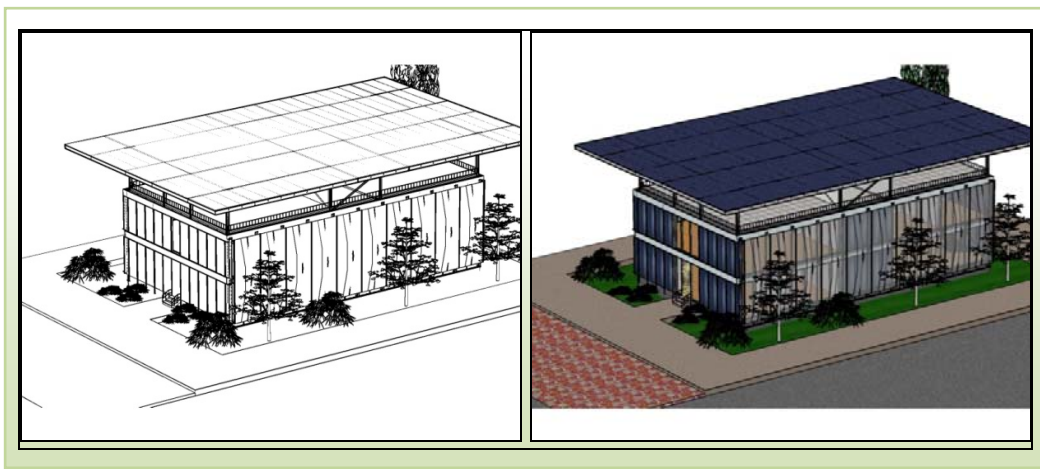

Fig 85: 3D models produced by the BIM within pdf. file

7 Discussing the results

It has being said “a picture is worth a thousand words”. Figure (86) depicted the final picture of the proposed system components and its end results (system architecture).

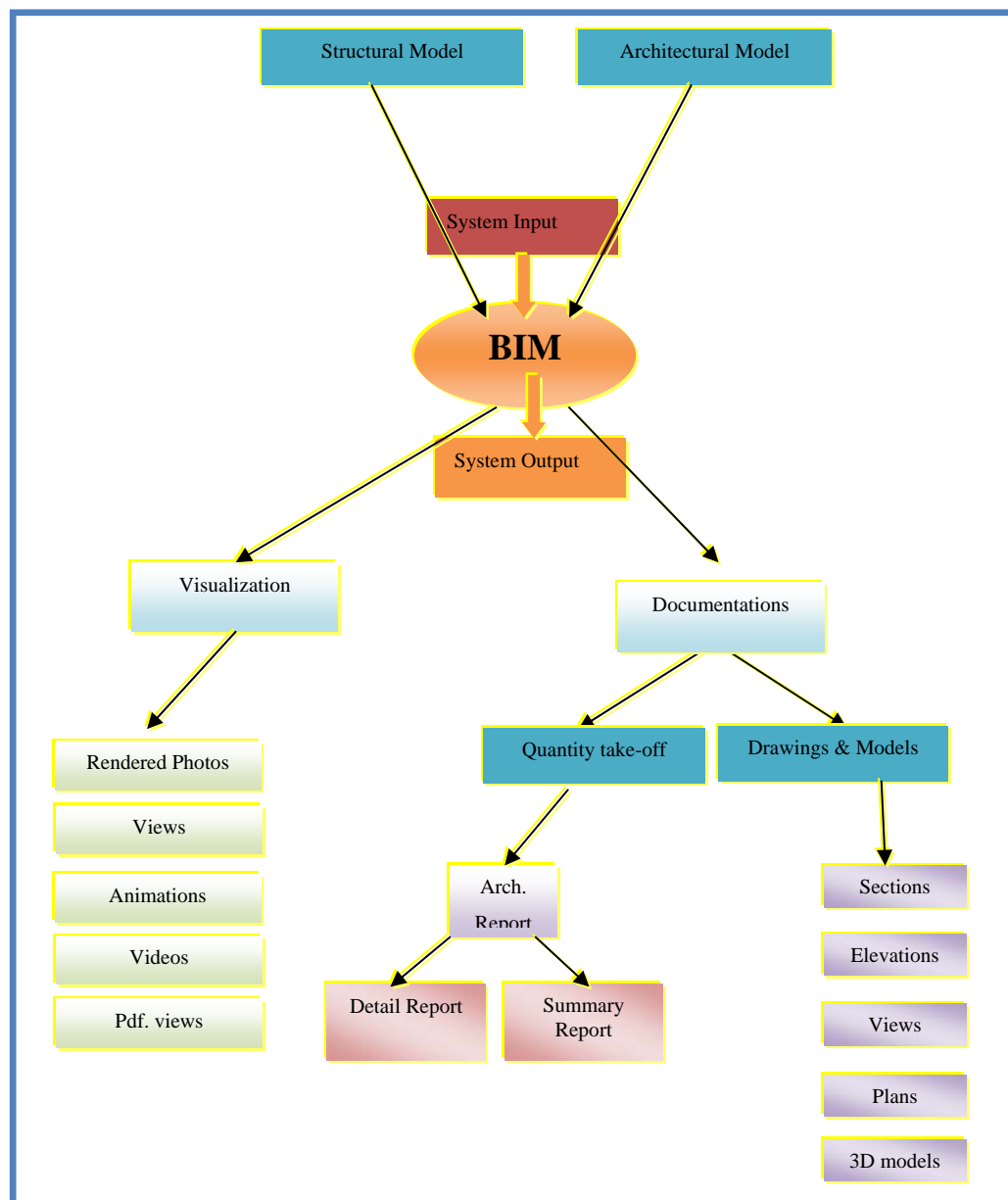

Fig 86: Illustrates proposed BIM system architecture

As already mentioned, this system consists of two 3D models of the architectural and structural system of the proposed office building. It is evident from the findings and the picture in figure (86) that the proposed BIM system has achieved most requirements and tasks anticipated. Simultaneously, many of these tasks are achieved as easy as a simple push of a key, especially how accurate and fast producing the quantity reports were. Traditionally, estimators produce this kind of reports by digitizing their paper drawings or importing their CAD into estimate packages or doing manual takeoffs from their drawings which would take days to accomplish depending on the size of the project. These methods are prone to human errors, inaccuracy and inconsistency which can be avoided using BIM systems instead of the drawings. BIM insures information consistency with the design and when a change is made to the model, the report is automatically updated as well as all other associated construction documents and schedules.

In fact, unlike ordinary CAD systems, BIM is about the information (B“I”M) that is being gathered in the back during the designing stage of the 3D models. Now, this is where the “I” in the middle comes to play, since BIM systems are supposed to build up their database (information about component of the building) as the 3D model evolves and develops; however, this knowledge is still not fully comprehended by the AEC professionals. The development of the “I” about the 3D model requires a great deal of interference from the designer and has not been made simple, although this is supposed to be automatically done as the software developer’s claim.

Practically speaking, there is a lot of effort needed to extract quantity reports from the BIM, at least when using Bentley’s MicroStation, which perhaps could be also applied to other BIM applications. Although these tools promise automation and effortless production of

documentation, there is still great deal of human involvement to achieve data extraction.

In fact, interference with the database and changing it was necessary to extract documents, reports and drawings, etc. For example, to extract a simple drawing from the system, the user must be able to access the system' database, change and choose the desire requirement including, line thickness, colors, etc.

7.1.1 Outputs break down

The preceding chart (Fig. 86) illustrates the proposed BIM system architecture. However, the next diagram (Fig. 87) categorized the system's outputs according to the types of produced document which are:

- 1) engineering views;
- 2) quantity reports; and
- 3) drawings and details.

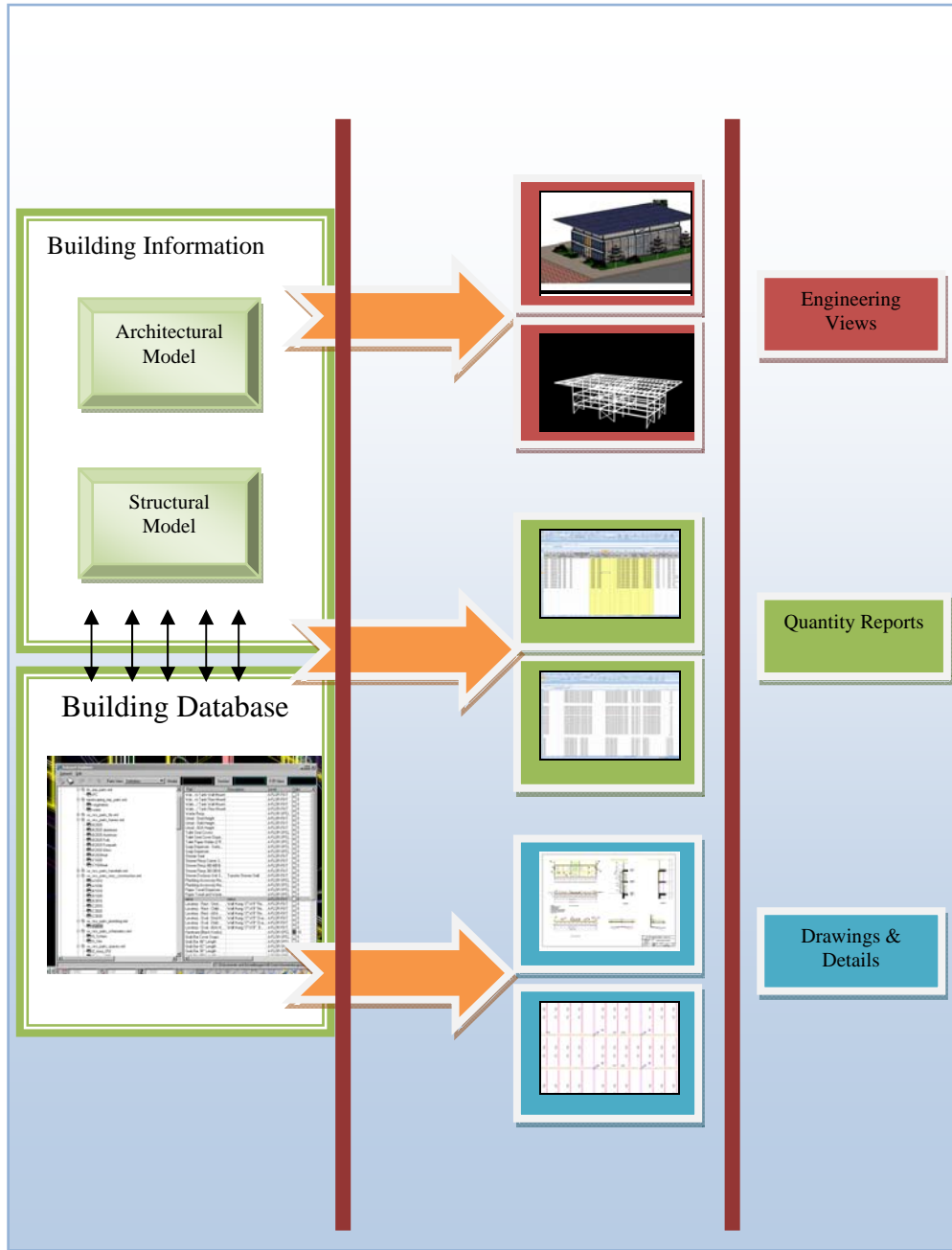

Fig 87: Categorizing the BIM system outputs

7.1.2 Distributing BIM results among targeted disciplines

The final results of the proposed BIM system could also be divided according to disciplines involved within the AEC industry. In this case, the system targeted two specific disciplines (architects and structural engineers) which several documents are possibly produced in accordance as shown by figures (88 & 89).

7.1.2.1 Results for Architects

Figure (88) below illustrates the type of documents and drawings architects in general are interested of gaining from the proposed BIM system. For example, visualization which could be generated at any stage of the process and expected to be dimensionally consistent in every view. Most importantly the system enables architects to visualize the project early in the design stage in order to convey their design intent, convince a client, or sell the design. Additionally, the system produces accurate and consistent 2D drawings, 3D models and estimate reports at any stage of the design.

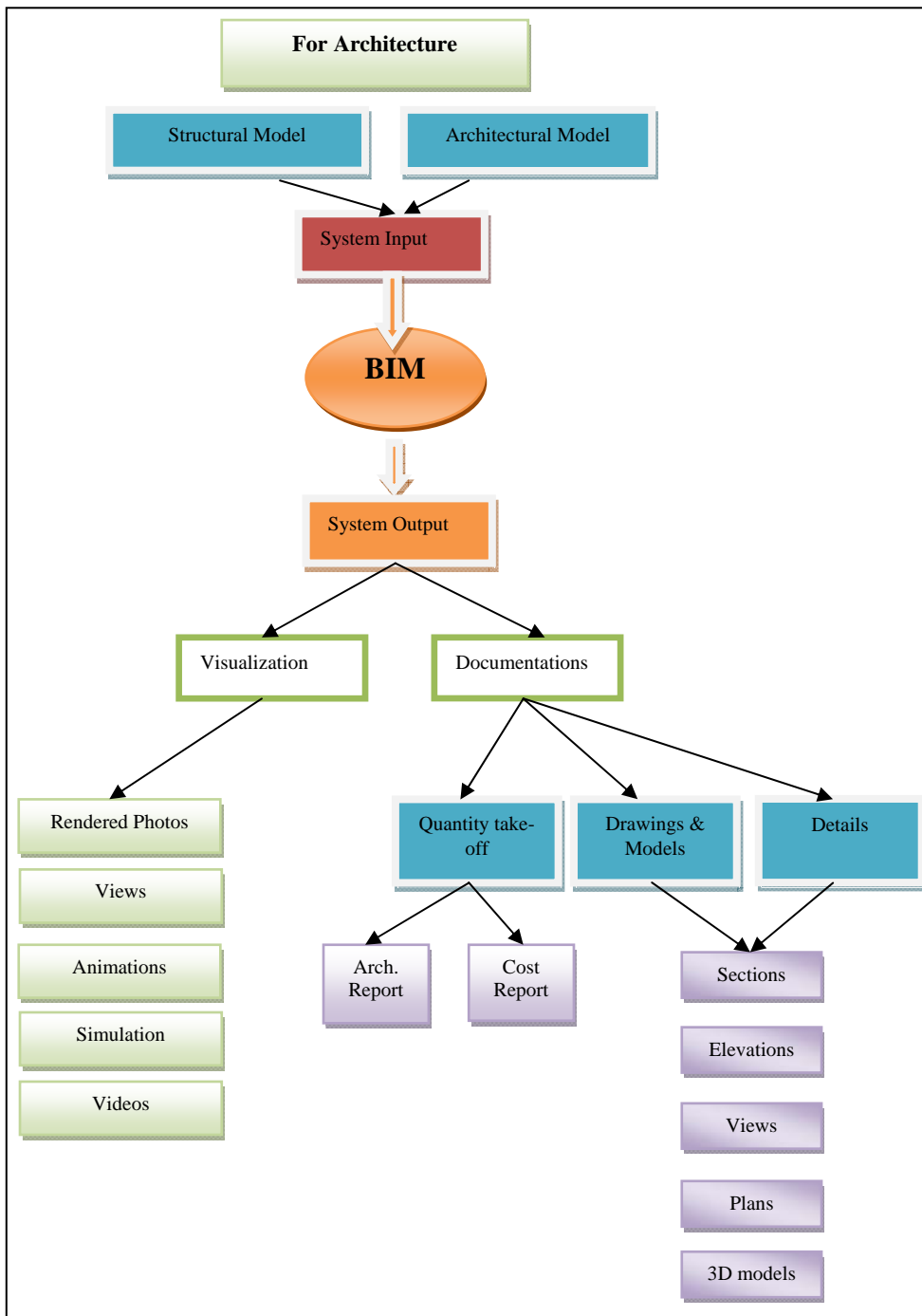

Fig 88: BIM system results for Architects

7.1.2.2 Results for Structural Engineers

From the structural model, the system produces accurate and consistency workshop drawings, details, documents, bills of materials, and views as requested by the structural engineer as illustrated in figure (89).

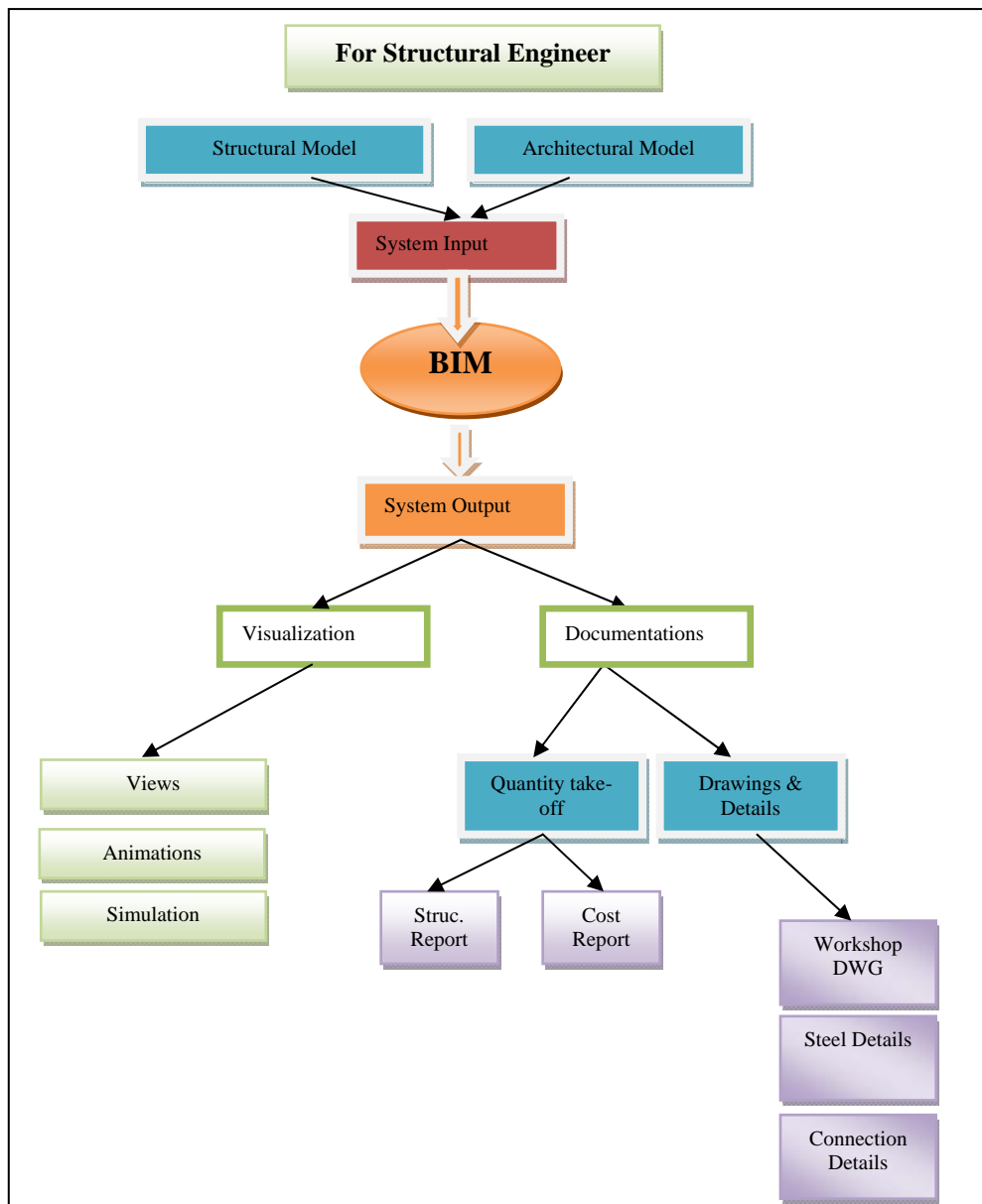

Fig 89: BIM system results for Structural Engineers

7.1.3 Managing Changes and Modifying Process

Since drawings are only reflections of actual and assumed information which are usually scattered among many drawings with countless duplicated and conflicting information items, therefore managing these changes is cumbersome and error prone [81]. Reichardt [82] acknowledged that BIM is the respond to waste within the AEC industry which faces challenges because so many diverse players are involved and because it is difficult to bridge their different information systems. For example, if a plumber contractor finds a design error that must be fixed by changing the floor plan, that change may affect other project participants. Most certainly, this change will cascade wildly through schedules and budgets, resulting in substantial cost over-runs. He suggested using BIM technique enables for change proposal to be reviewed in terms of their implications, with efficient checking by multiple participants, resulting in both better planning and reducing expensive mid-construction changes. Also, indicated by Day [83] all drawings produced by BIM would be views of a single model which are automatically co-ordinate and if a component, such as a window, were moved there would be no need to ensure that every drawing containing that window was changed accordingly.

An example of “how the proposed BIM system can distribute changes or modifications of design element among associated document?” is illustrated by figure (90).

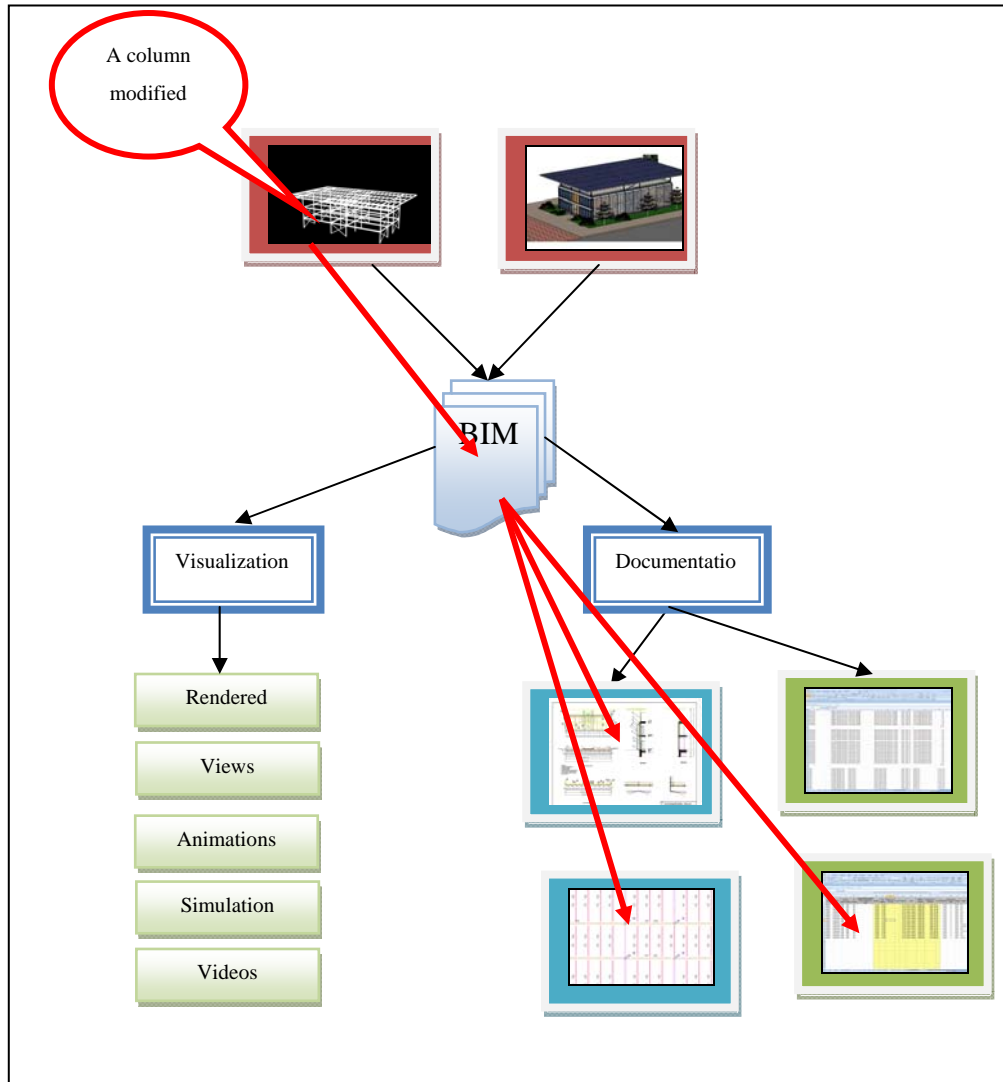

Fig 90: Illustrates changing or modifying process

7.2 Conclusion

The proposed BIM system has illustrated that extracting data and documents although possible, it is still time consuming process and difficult to master. In fact, each activity requires a specialist to perform. For example, rendering a front view of the model involves several tasks such as, applying materials, textures, lights, etc. which are not made easy by the software. Also, producing a vertical or horizontal section from the system requires a great deal of work within the program's database to achieve these tasks. In addition, every single element contained within the model is uniquely represented in the database, thereby the program needs to identify and execute each element in order to be included and extracted. Thus, working with the database is very tedious and requires a great deal of learning, which raises the question: who is willing or who would pay for this learning period? Robinson [81] strongly believes that BIM will become the future way of working, however a new a specialist will have to be added to the design team who will be responsible for just producing the BIM data. However, the introduced specialist could be employed directly by the owner for contract control or by other design team members. Thus, the cost will be controlled by the model, which will then be a major interest of the client, quantity surveyor or project cost control.

Moreover, findings throughout this dissertation suggests that BIM is most likely to positively impact the way buildings are constructed in quality and on time completion. However, more research are needed to fully realized this technology and harvest its benefits. Some thinks, only time and results will determine whether BIM endorsement will

bring collaboration and efficiency to the AEC industry and reduce project's cost and delivery time.

In fact, what the AEC industry hopes and what is being thought and discussed throughout literatures and research, is that information captured digitally within the BIM system can then be presented as coordinated documents, be shared across multi disciplines, and serve as a centralized design management tool. Yet, the ideal system is anticipated to digitally represent the physical and functional characteristics of a building and with the help of simulation tools the system can detect and avoid clashes in a virtual world where interferences are eliminated before construction ever begins. Indeed, software vendors and the industry also wish to have BIM serve as a source for information about a facility forming a database for decisions making during its life-cycle from inception onward. They also anticipate BIM systems to include everything related to the building before construction and to store all building information in one location which eliminates inconsistency and data overlap that may lead to expensive construction errors. The aim is to insure that every participant is working with the same exact information as everyone else in the project and changes are made to objects only once.

Certainly, as mentioned in the proceeding chapter, achieving BIM system including all architectural, structural and services objects information is still far from reality, however figure (91) represents the ideal BIM system with most common inputs and outputs at least within the AEC industry. This system contains several models (architecture, structure, HVAC, MEP, site model, FP model, etc) produced by different specialized individuals with different levels of details and different software tools. In addition, this BIM system could be linked to many other tools and applications (i.e. energy analysis programs, clashes and interferences detecting programs, performance simulations

software, structural optimization programs, etc.) to be the only reliable basis for decisions during the facility life-cycle from inception onward.

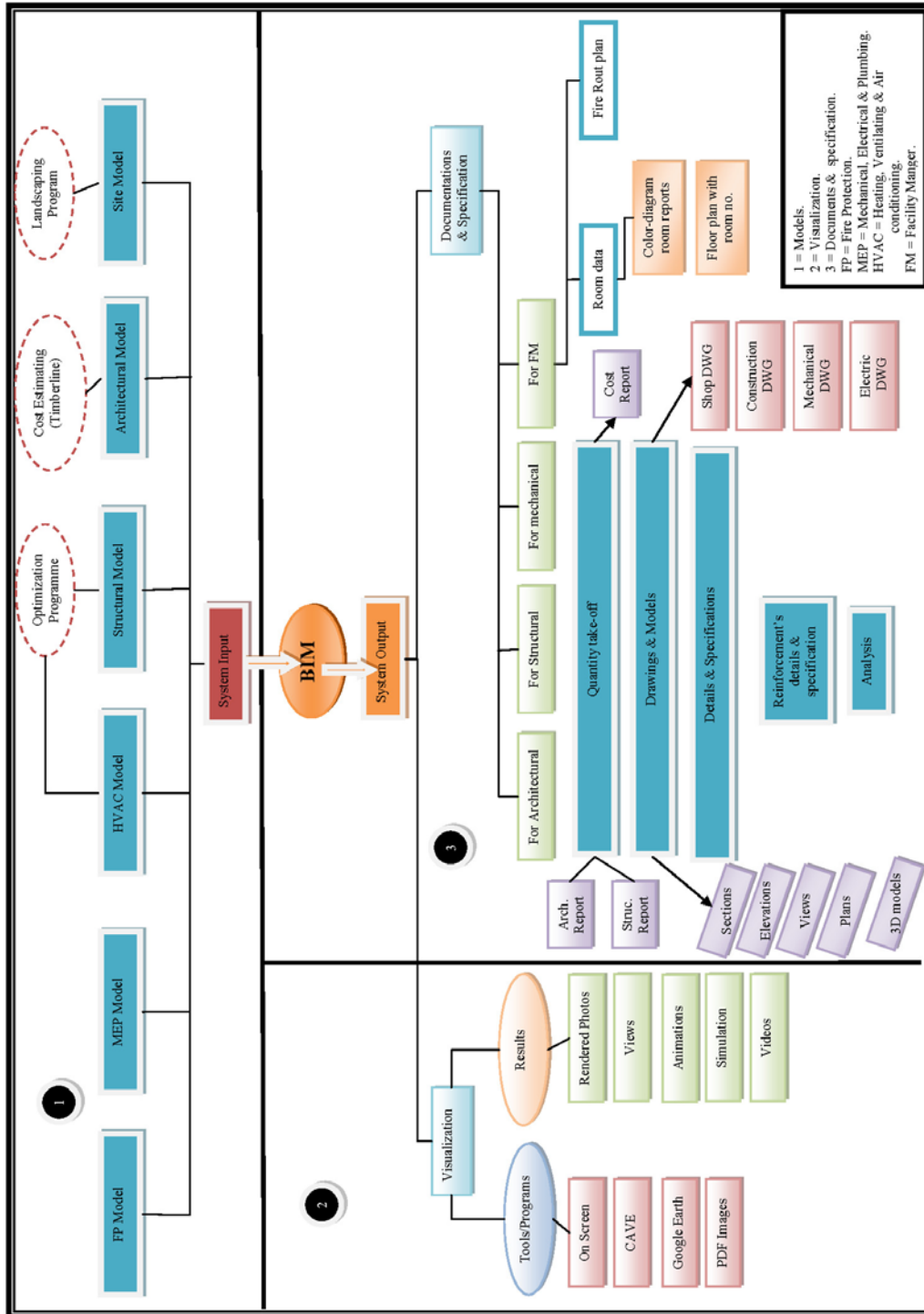

Fig 91: Illustrates a typical BM system architecture

8 Overall Conclusions and Recommendations

This dissertation has started with a discussion of computer tools and applications which for over three decades have played a major role in the AEC industry and have progressed from being expensive and highly specialized calculation machines to general-purpose tools available on every desktop. Although, some of the software on the market, such as word processors and spreadsheets, are easy to learn and used productively, CAD packages are challenging and more difficult to master. This is due to vendors aiming to automate the construction of a facility from original concept to design and construction to ongoing operations and maintenance as one process. Unlike other industries, such as banking and insurance, where many of the tasks are straightforward and repetitive, in which computers improved productivity and services; the construction industry, where building closer to prototypes than mass-produced good, the impact of computers is much harder to quantify and many agree that new technology has not been utilized effectively. However, Day [83] points out such technology can greatly improve the way in which information is processed and communicated and therefore offers new opportunities. It promises the automation of construction tasks and activities as well as blurring the existing boundaries between disciplines and to realize the aim of creating an integrated database of project information to be used by all participants.

Thus, the AEC industry is growing rapidly with new project delivery methodologies are being embraced and designing of facilities is continuously improving. Additionally, the industry has long sought techniques and methods to increase productivity and quality, and reduce project delivery time as well as decreasing overall project cost.

However, the overall impression about this industry that it tends to resist automation; yet the advance of computers and the increase ability to model buildings using 3D models systems promises to shift that impression. In fact, the AEC industry involves many teams from different fields that have a specific role along the facility life cycle. Each of the teams' members (architect, engineer or project manager) contributes to one part of the building completion. Thus, finding ways to combine these tasks and improve collaboration and communication between project teams will lead to improving profitability, reduce cost, better time management and improved customer/client relationships. Therefore, 3D and Building information modeling (BIM) offer the potential to achieve these objectives which hold tremendous promises for the future of AEC industry and how projects are achieved. It is believed, the future of the AEC industry is going to be driven by the use of BIM technology, which acts as a single-source of repository for information about a building and it aims to integrate every aspect of that building.

However, the implementation of 3D modeling and BIM in the AEC industry is inevitable; even though the industry still has to get over several obstacles and hurdles in order to achieve full 3D virtual modeling and BIM. One of these obstacles is "how to implement BIM into AEC firms?" Unlike many other construction practices, currently there are no clear instructions or roles on "how to implement or use BIM", which raise the urgent need to standardize the BIM process and to define an outline for its implementations. Meaning, a national standard is required to promote communication across software platforms to drive adoption and improve collaboration and communication between stakeholders.

Also, the AEC industry participants are concern regarding, who should develop and operate the building information and how the cost of

development and operational costs is distributed? “If all can contribute, who should lead and who is responsible for failure?” [76] Therefore, control over the BIM model raises the question: who owns and maintains the model? In addition to legal and risk management issues earlier discussed.

Another major concern is related to the ability of BIM software to exchange information with other computer applications (interoperability). While the benefit of BIM and 3D modeling are well established and more firms are using BIM, each member of the project’s team tends to have their own tool which cannot be integrated with the others, resulting in duplication of information and poor communication. Therefore, a common set of standards must be established and implemented by all software vendors in the industry to allow for better communications and to improve data exchange ability.

8.1 Recommendations

Although, the use of BIM is expected to continue to increase in the AEC industry, AEC stakeholders and researchers have to develop suitable solutions to overcome challenges and obstacles [66]. In addition to standardization issues, some key aspects that will impact the future of BIM endorsement are:

BIM education and training: the recent evolution of BIM software and its endorsement among the AEC industry suggests that BIM holds tremendous promises for the future of buildings and therefore, it must be introduced to students at educational institutes [77]. In addition, the benefits to students must be researched and evaluated to give them the best opportunity for future employment. Moreover, implementing BIM takes effort and demands careful planning, and a significant amount of

education and training for all project participants. They must be informed regarding benefits BIM can bring to both the project and the construction team as well as trained in the new workflow [23].

Real world case studies: Quantifying the impact of a BIM approach through real world construction case studies will offer a more compelling argument for BIM adoption by the AEC industry [78].

Establishing database of knowledge: there is a need to establish a source (database) with knowledge and experience in the use and practices of BIM to be available for potential BIM users.

Research in BIM: investment in the research and development in building information modeling will greatly benefit the AEC industry. As the use of BIM is expected to improve collaboration and communication between project teams which will lead to improving profitability, reduce cost, better time management and improved customer/client relationships.

9 References and Bibliography

- [1]. Young Jr. N. W., Jones S.A., and Bernstein H.M.(2007) *Interoperability in the Construction Industry: SmartMarket Report*. [online] Available from: http://construction.ecnext.com/mcgraw_hill/includes/SMRI.pdf [accessed 15 October 2008].
- [2]. Kymmell, W. (2008) *Building Information Modeling: planning and managing construction projects with 4D CAD and simulations*. USA: McGraw Hill.
- [3]. Kato, N., Okano, A. and Okuno, T. (1999) *Modeling Virtual Cities Using Genetic Algorithms*. 1999 IEEE Midnight-Sun Workshop on Soft Computing Methods in Industrial Applications. Kuusamo, Finland, June 16-18, 1999. [online]. Available from: <http://ieeexplore.ieee.org/stamp/stamp.jsp?arnumber=00782722> [accessed 22 October 2008].
- [4]. Dodge, M. , Smith, A. and Doyle S. (1997) *Virtual Cities on the World-Wide Web: Towards a Virtual City Information System*. [online]. Available from: http://www.casa.ucl.ac.uk/martin/virtual_cities.html [accessed 10 October 2008].
- [5]. Batty, M., Chapman, D., Dale, P., Densham, P., and Harley, I. (2006) *Virtual London: A proposal*. [online]. Available from: <http://www.casa.ucl.ac.uk/vl.html>. [accessed 14 March 2006].
- [6]. Franklin, R., Heesom, D. and Felton, A. (2006) *A Critical Review of Virtual Reality and Geographical Information Systems for Management of the Built Environment*. Proceeding of the Information Visualization (IV'06), July 5-7-2006, London, England: IEEE computer Society Press.
- [7]. Bourdakis. *Virtual Reality: A communication tool for Urban Planning*. Bath, UK: Centre of Advanced Studies in Architecture: University of Bath. [Online]. Available from: <http://fos.prd.uth.gr/vas/papers/CAAD-TNDC/> [accessed on 22 October 2008].
- [8]. Croser, J. (2006) *MicroStation Connects to Google Earth Tools*. BE magazine [online], 3(1),pp.22-24. Available from: <http://www.nxtbook.com/nxtbooks/bemagazine/vol3issue1/> [accessed 1 July 2008].

- [9]. Czermuszenko, M., Pape, D., Sandin, D., DeFanti, T., Dawe, G.L., and Brown, M.D. (1997) *The ImmersaDesk and Infinity Wall Projection-Based Virtual Reality Displays*. *Computer Graphics*. Available from: <http://www.evl.uic.edu/pape/CAVE/idesk/paper/> (accessed 4 June 2007).
- [10]. Karp, R and Quinn, B. (2004) *Computer Aided Design More than Just an Electronic Pencil and Paper*. *Structure magazine [online]* July 2004. Available from: www.structuremag.org/OldArchives/2004/july/The%20Power.pdf [accessed 8 April 2008].
- [11]. Demchak, G., Dzambazova, T. and Krygiel, E. (2008) *Introducing REVIT® Architecture 2009: BIM for Beginners*. Canada:Wiley.
- [12]. Faulkner, L. (2006) *Interoperability for the Steel Industry*. *Structure magazine [online]*, November 2006, page 18. Available from: <http://www.structuremag.org/archives/2006/February-2006/C-Technology-Feb-06.pdf> [accessed 26 March 2008].
- [13]. Smith, D. (2007). *An Introduction to Building Information Modeling (BIM)*. *Journal of Building Information Modeling (JBIM) [online]*, Fall 2007. Available from: http://www.wbdg.org/pdfs/jbim_fall07.pdf [Accessed 23 July 2008].
- [14]. Laasonen, M., and Karlakari, T. (2006) *Maintaining data in building model-based facility management system*. *Symposium, Changing user demands on buildings*, edited by Haugen, T.I., Moun, A. , Bröcher, J., Norwegian University of Science and Technology, Trondheim, 2006 .pp.306-316. Available from: http://www.tut.fi/units/rka/rtt/tutkimus/rakennusmittaus/CI BW70_2006_Model_to_FM.pdf (accessed 20 January 2008).
- [15]. See, R. (2007). *Building Information Models and Model Views*. *Journal of Building Information Modeling (JBIM) [online]*, Fall 2007. Available from: http://www.wbdg.org/pdfs/jbim_fall07.pdf [Accessed 23 July 2008].
- [16]. Erger K. (2007) *The Rewards and Risks of BIM [online]*, Available from: <http://karenerger.com/Documents/BIM%20Risks%20and%20Rewards.doc>. [accessed 24 September 2007].
- [17]. Smith, D. K. and Edgar, A. (2007). *Building Information Models (BIM)*. WBDG (Whole Building Design Guide). www.wbdg.org/resources/bim [updated 07-09-2007 accessed 18 January 2008].

- [18]. DeStefano, J (2007) *Computer Technology in the Practice of Structural Engineering* [online], *Structure magazine* May 2007. Available from: <http://www.structuremag.org/Archives/2007-5/C-Technology%20-%20DeStefano-May07.pdf> [accessed 27 March 2008].
- [19]. Kennetts, E (2006) *National Building Information Model Standards Committee Formed New NIBS Group Will Create U.S. BIM Standard*. National Institute of Building Science. Available from: <http://www.nibs.org/newsstory1.html> [updated 2008 accessed 19 January 2008].
- [20]. Autodesk (2007) *REVIT building information modelling. BIM in Action* [online], Available from: http://images.autodesk.com/latin_am_main/files/Revit_BIM_Oculus_CAD_Mgr_Jun05.pdf [accessed 24 September 2007].
- [21]. Brucker B. A., Case, M. P., East, E. W. Huston, B. K., Nachtigall, S. D., Shockley, J. C., Spangler, S. C. and Wilson, J. T. (2006) *Building Information Modeling (BIM): A Road Map for Implementation To Support MILCON Transformation and Civil Works Projects within the U.S. Army Corps of Engineers* [online], Available from: https://cadbim.usace.army.mil/MyFiles/ERDC_TR-06-10.pdf [accessed on 12 September 2007].
- [22]. Autodesk Revit white paper (2005) *Building information Modeling for Sustainable Design* [online] Available from: http://www.ddscad.com/BIM__Sustainable_Design.pdf [accessed on 7 September 2007].
- [23]. Cyon Research (2003) *The Building Information Model: A Look at Graphisoft's Virtual Building Concept* [online], Bethesda, USA. Cyon Research Corporation. Available from: http://wbh.com/WhitePapers/Graphisoft_Virtual_Building_Model--a_Cyon_Research_White_Paper_030102.pdf [accessed on 12 May 2005].
- [24]. Industry Directions (2006) *Leveraging the Value Chain in Construction Building information Modeling* [online]. Available from: <http://www-304.ibm.com/jct03004c/tools/cpeportal/files/serve/download1/41842/Construction.pdf?contentid=41842> [accessed 28 March 2008]
- [25]. Turner, B. (2005) *Integrate Design with Construction and Operating Costs Using BIM*. The American Institute of Architects (AIA). Available from: http://www.aia.org/k_a_200612_ftr (updated 2007, accessed 24 September 2007).

- [26]. Autodesk (2007) *BIM in Action* [online] Available from: http://www.therightangle.ie/Uploads/product_data/revit%20architecture%202008/revit_bim_in_action_jan07.pdf [accessed 24 September 2007].
- [27]. Yoders, J. (2006). *The Merry Road to BIM. Building Design and Construction* [online]. Available from: <http://www.bdcnetwork.com/article/CA6354606.html?industryid=42772&q=jeff+yoders%2C+the+merry+road+to+bim> [accessed 27 March 2008].
- [28]. Rocha, L. (2003) *Comprehensive Building Modelling. Architecture Week: Page T1.1. 25 June 2003. online*. Available from: http://www.architectureweek.com/2003/0625/tools_1-1.html (accessed 15 January 2008).
- [29]. Dossick, C. S. (2006) *Building Information Modeling (BIM) – Fully Integrated and Automated Project process (FIAPP)* [online]. Available from: <http://faculty.washington.edu/cdossick/research.shtml> [updated 8 March 2006, accessed 24 September 2007].
- [30]. Williams, PE. S. D., (2007) *Construction Document Changes to Improve Constructability. National Conference on Building Commissioning: May 2-4, 2007. Available from: http://www.peci.org/nbc/proceedings/2007/Williams_NCBC2007.pdf* (accessed 15 January 2008).
- [31]. Autodesk (2003) *Building Information Modeling: A Key to Performance-Based Design* [online], Available from: http://images.autodesk.com/adsk/files/bim_a_key_to_performance-based_design.pdf [accessed 24 September 2007].
- [32]. Huell, E., (2006) *Building Information Modeling: Collaboration, Integration, and Interoperability. U.S. Army Corps Engineers. The CAD/BIM Technology Centre Available from: https://cadbim.usace.army.mil/MyFiles/EdwardHuellBIM_FINAL.pdf* (accessed on 12 September 2007).
- [33]. Matta, C., Kam, C., Clevenger, C., Ho P. (2006). *GSA's National 3D-4D-BIM Program. [online] Available from: http://www7.nationalacademies.org/ffc/2calvin_kam_gsa.pdf* (accessed 15 January 2008).
- [34]. Harris, D. A. (2007) *Message from NIBS "This new and significant journal will be an essential information source on business, standards and technical issues related to Building Information Modeling."* *Journal of Building Information Modeling*, (Fall 2007), Available from: http://www.wbdg.org/pdfs/jbim_fall07.pdf (accessed 17 June 2008).

- [35]. East, E. W. (2007). *BIM for Construction Handover*. *Journal of Building Information Modeling (JBIM)* [online], Fall 2007. Available from: http://www.wbdg.org/pdfs/jbim_fall07.pdf [Accessed 23 July 2008].
- [36]. Hartmann, T. and Fischer, M. (2008). *Application of BIM and Hurdles for Widespread Adoption of BIM*. 2007 AISC-ACCL eConstruction Roundtable Event Report. CIFE Working Paper #WP105. Revised – FEBRUARY 2008. Stanford University. Available from: <http://cife.stanford.edu/online.publications/WP105.pdf> [accessed 30 July 2008].
- [37]. Edgar, A. (2008) *Building Value through Building Information Innovation*. *Journal of Building Information Modeling (JBIM)* [online], Spring 2008. Available from: http://www.wbdg.org/pdfs/jbim_spring08.pdf [Accessed 23 July 2008].
- [38]. Bernstein and Pittman (2005) *Barriers to the adoption of Building Information Modeling in the Building Industry*. Autodesk building solutions white paper. [online] Available from: http://images.autodesk.com/adsk/files/bim_barriers_wp_mar05.pdf[accessed 19 January 2009].
- [39]. NIST (2004) *Cost Analysis of Inadequate Interoperability in the U.S. Capital Facilities Industry*. U.S. Department of Commerce. National Institute of Standards and Technology. Available from: <http://www.bfrl.nist.gov/oae/publications/gcrs/04867.pdf> [accessed 24 October 2008]
- [40]. Howard, R and Bjork, B. (2003) *Building information models – experts' views on BIM/IFC developments*. [online] Available from: <http://itc.scix.net/data/works/att/w78-2007-007-043-Howard.pdf> [accessed 7 February 2008]
- [41]. NavisWorks (2008) *Working together you can achieve more with JetStream*[online] Available from: <http://navisworks.com/de> [accessed on 4 June 2008]
- [42]. Bentley (2008) *MicroStation Platform Technology and Products* [online] Available from: <http://www.bentley.com/en-US/Products/MicroStation+Product+Line/> [accessed on 22 April 2008].
- [43]. VICOsoftware (2008) *Vico software: Integrating Construction*. [online] Available from: <http://www.vicosoftware.com/> [accessed 10 October 2008].

- [44]. Nemetschek (2008) "Home page". [online] Available from: <http://www.allplan.com/en/home.html> [accessed 10 October 2008].
- [45]. 4BIM (2007) 4BIM discussion [home page] <http://www.4bim.com/> (accessed on 17 November 2005).
- [46]. Halfawy, M. and Froese, T. (2005) Integration of data and processes of AEC projects using the industry foundation classes. 6th Construction Specialty Conference, Toronto, Ont., June 2-4, 2005, pp. 1-10.
- [47]. Howell, I and Batcheler, B. (2005) Building information Modeling Two Year Later – Huge Potential, Some Success and Several Limitations. [online] Available from: http://www.laiserin.com/features/bim/newforma_bim.pdf [accessed June 2008].
- [48]. Autodesk (2005) Parametric Building Modeling: BIM's Foundation [online] Available from: www.ideateinc.com/whitepapers/all/Revit-%20Parametric%20Building%20Modeling%20Foundation.pdf (accessed 2 June 2008).
- [49]. Eastman C., Teicholz P., Sacks R., and Liston K. (2008) BIM Handbook: A Guide to Building Information Modeling for Owners, Engineers, and Contractors. New Jersey: John Wiley & Sons, Inc
- [50]. Edgar, A. (2007) "The Committee recognizes that this is a deceptively simple concept requiring a great deal of cooperation for the good of all and, for this reason, frequent and open communication is a key success factor, " Journal of Building Information Modeling (JBIM) [online], (Fall 2007), Available from: http://www.wbdg.org/pdfs/jbim_fall07.pdf [Accessed 17 June 2008].
- [51]. SOLIBRI (2008). The World Leader in Design Spell Checking. [online], Available from: <http://www.solibri.com/building-information-modeling/ifc-and-bim.html> [accessed 17 January 2008].
- [52]. Vectorworks (2008) Nemetschek North America Announces Public Beta for Upcoming IFC Version 2x3 Plug-ins and GSA-compliant Space Object. [online], Available from: <http://www.nemetschek.net/news/pressreleases/2007/041807.php> [accessed 18 January 2008].

- [53]. Wikipedia (2008) *The world free encyclopedia* [online], Available from:
http://en.wikipedia.org/wiki/Industry_Foundation_Classes
 [accessed 21 January 2008]
- [54]. BE Magazine (2005) *Building Design Reflects Dynamic Stability, Architectural firm's use of 3D model cuts design time in half, improves accuracy* [online], BE magazine, volume 3, Issue 1. Available from: <http://www.nxtbook.com/nxtbooks/bemagazine/vol3issue1/index.php> [accessed 19 January 2008]
- [55]. Al-Charieh, K. (2008) 3D-Labour: TU Berlin. www.math.tu-berlin.de/3d-labor. Personal interview.
- [56]. Yoders, J. (2007) *Acrobat 3D 8 makes 3D/CAD file-sharing easier* [online]. *Building Design and Construction*. [online] Available from: <http://www.bdcnetwork.com/article/CA6466254.html> [accessed 14 July 2008].
- [57]. Flynn, J. (2005) *Rendering with MicroStation*, Exton, USA: Bentley Institute Press; 2005. 413p.
- [58]. Bentley (2009) *A Source of Innovation, a CAD Platform for Integration* [online] Available from: www.bentley.com/en-US/Products/MicroStation/Interactive+3D+PDF.htm [accessed on 12 February 2009].
- [59]. Market Wire (2008) "Resolving Risk Issues Key to Widespread Adoption of BIM". Market Wire. May 2008. FindArticles.com. 28 Jul. 2008. [online] Available from: http://findarticles.com/p/articles/mipwwi/is_200805/ai_n25415885. [accessed 25 April 2009].
- [60]. AIA (The American Institute of Architects) (2007). *2007 AIA Digital Practice Documents*. [online] Available from: <http://www.aia.org/SiteObjects/files/2007%20Digital%20Practice%20Documents.pdf> [accessed 28 July 2008]
- [61]. BE Magazine (2006) [online] *2006 BE Award Winner. A Marriage of Science and Nature. BIM saves months off timeline during design of six-story hospital in park-like setting* [online], BE magazine, volume 3, Issue 4. Available from: <http://www.nxtbook.com/nxtbooks/bemagazine/vol3issue4/> [accessed 1 July 2008]
- [62]. SIAP (2003) *Society of Iranian Architects & Planners. Bam: Killer Earthquake*. [online] Available from: <http://www.siap.org/News/Bam-EQ2003/BamEQ2003.htm> [accessed 7 February 2008].

- [63]. Smilow, J (2007) *Practical BIM. How are engineers and architects implementing and using the developing technology?* *Modern Steel Construction* (November 2007). [online] Available from: http://www.modernsteel.com/Uploads/Issues/November_2007/112007_30771_WSP_cantor_web.pdf [accessed 20 January 2009].
- [64]. Howard, R. and Bjork, B. (2007) *Building Information Models – Experts’ view on BIM/IFC developments.* *ITC Digital Library.* [online] Available from: <http://itc.scix.net/data/works/att/w78-2007-007-043-Howard.pdf> [accessed 20 January 2009].
- [65]. Bacon, S. (2008) *BIM Crosses Boundaries at Seattle-Area High Rise.* *Structural magazine* [online] January 2008. Available from: <http://www.structuremag.org/Archives/2008-1/SF-BIM-Hyatt-Hotel-Bacon-Jan-08.pdf> [accessed 26 January 2009]
- [66]. Azhar S., Nadeem, A., Mok, J.Y.N., Leung, B.H.Y (2008) *Building Information Modeling (BIM): A New Paradigm for Visual Interactive Modeling and Simulation for Construction Projects.* *First International Conference on Construction in Developing Countries (ICCIDC-1) “Advancing and Integrating Construction Education, Research & Practice” August 4-5, 2008, Karachi, Pakistan.* [online] Available from: <http://www.neduet.edu.pk/ICCIDC-1/Conference%20Proceedings/Papers/045.pdf> [accessed 28 January 2009].
- [67]. Wyatt, G. (2007) *Maintaining BIM Integrity in the Structural Engineering Office.* *Autodesk-REVIT® STRUCTURE.* [online] Available from: http://images.autodesk.com/adsk/files/maintaining_bim_integrity_in_structural_engineering_office.pdf [accessed on 28 January 2009].
- [68] Condon, T. (2006) *Building Information Modeling. This approach to project documentation has the potential to synthesize the entire life cycle of a facility.* *Today’s Facility Manager,* (November 2006) [online] Available from: http://www.todaysfacilitymanager.com/tfm_06_11_factech.php [accessed on 28 January 2009].
- [69]. Khemlani, L. (2006) *Use of BIM by Facility Owners: An “Expositions” Meeting.* *AECbytes “Building the Future.* (May 16, 2006) [online] Available from: http://www.aecbytes.com/buildingthefuture/2006/Expositions_meeting.html [accessed on 28 January 2009].

- [70]. AGC (2005) *the Contractors' Guide to BIM, 1st ed. The Associated General Contractors of America.* [online] Available from: <http://www.agcnebuilders.com/documents/BIMGuide.pdf> [accessed on 29 January 2009].
- [71]. Goldberg, E. (2006) *AEC From the Ground Up-State of the AEC Industry 2006. BIM solutions are changing the AEC landscape.* *Cadalyst*, May 1, 2006 [online] Available from: <http://aec.cadalyst.com/aec/article/articleDetail.jsp?id=324995> [accessed on 31 January 2009].
- [72]. Goldberg, E. (2005) *AEC From the Ground Up-State of the AEC Industry. BIM implementation slow, but inevitable.* *Cadalyst*, May 1, 2005 [online] Available from: <http://aec.cadalyst.com/aec/article/articleDetail.jsp?id=161716> [accessed 31 January 2009].
- [73]. Azhar, S., Hein, M., Sketo, B. (2008) *Building Information Modeling (BIM): Benefits, Risks and Challenges.* [online] Available from: <https://fp.auburn.edu/heinmic/Pubs/ASC%202008-BIM%20Benefits.pdf> [accessed 31 January 2009].
- [74]. Kunz, J., Gilligan, B. (2007) *Value from VDC / BIM Use: Survey Results.* *Center for Integrated Facility Engineering (CIFE) Stanford University*, 6 November 2007 [online] Available from: <http://cife.stanford.edu/VDCSurvey.pdf> [accessed on 31 January 2009].
- [75]. Khemlani, L. (2007) *Top Criteria for BIM solutions: AECbytes Survey Results.* *AECbytes*, October 10, 2007. [online] Available from: www.aecbytes.com/feature/2007/BIMSurveyReport.html [accessed 31 January 2009].
- [76]. Thomson, D. (2001) *The construction law briefing paper.* [online] Available from: <http://www.minnlaw.com/Articles/68553.pdf> [accessed 9 February 2009].
- [77]. Taylor, J. M., Liu, J., Hein, M. F. (2008) *Integration of Building Information Modeling (BIM) into an ACCE Accredited Construction Management Curriculum.* [online] Available from: <https://fp.auburn.edu/heinmic/Pubs/ASC%202008-Integration.pdf> [accessed 10 February 2009].
- [78]. Suermann, P.C., Issa, R. R.A. (2007) *Evaluating the Impact of Building Information Modeling (BIM) on Construction.* *7th International Conference on Construction Applications of Virtual Reality: October 22-23, 2007.* [online] Available from: http://www.engr.psu.edu/convr/proceedings/papers/22_Suermann_submission_47.pdf [accessed on 10 February 2009].

- [79]. AECbytes "Building the Future". (2005) *The CIS/2 Format: Another AEC Interoperability Standard* [online] Available from: www.aecbytes.com/buildingthefuture/2005/CIS2format.html [Accessed 29 January 2009]
- [80]. Hartmann, T., Goodrich, W.E., Fischer, M., Ederhard, D. (2007) *Fulton Street Transit Center Project: 3D/4D Model Application Report. CIFE Technical Report #TR170, May 2007: Stanford University.* [online] Available from: <http://cife.stanford.edu/online.publications/TR170.pdf> [Accessed 17 July 2008]
- [81]. Robinson, C. (2007) *Structural BIM: Discussion, case studies and latest developments. The Structural Design of Tall and Special Buildings* [online] December 2007; 16(4): 519-533. Available from: www3.interscience.wiley.com/cgi-bin/fulltext/116833538/PDFSTART [Accessed 15 April 2009].
- [82]. Reichardt, M. (2008) *CAD, Geospatial, 3D and BIM Standards Converge. GIS Development: The Global Geospatial Magazine* [online] April 2008. Available from: www.gisdevelopment.net/magazine/global/2008/april/56.htm. Accessed 2009 April 20.
- [83]. Day A (1997) *Digital Building*. Oxford: Laxton's:168p.
- [84]. Parish, Y. I. H., Müller P. (2001) *Procedural Modeling of Cities. ACM SIGGRAPH* [online] 12-17 August 2001; Los Angeles, CA, USA. Available from: http://graphics.ethz.ch/Downloads/Publications/Papers/2001/p_Par01.pdf [Accessed 23 April 2009].
- [85]. Wingly, S. (2005) *CAVE as Crit-Space: A single Display Croupware Application on Virtual Environment. CAAD Futures: learning from the Past. Special publication of papers presented at the CAAD futures 2005 conference held at the Vienna University of Technology, Vienna, Austria: June 20-25, 2005.*
- [86]. Whyte, J. (2002) *Virtual Reality and the Built Environment*. UK: Architecture Press.
- [87]. Birx, G. W. (2006) *BIM Creates Change and Opportunity. Adapted from an article originally published in AIArchitect* [online] October 2006. Available from: http://www.aia.org/aiaucmp/groups/ek_members/documents/pdf/aiap016610.pdf [Accessed 1 May 2009].
- [88]. Brucker, B. (2009) *Building Information Modeling to Benefit Entire Facility Life Cycle* [online] Available from: <http://www.cecer.army.mil/td/tips/docs/BIM-LC.pdf> [accessed 4 May 2009].

- [89]. *buildingSmartalliance (2009) United States National CAD Standard [home page] Available from: www.buildingsmartalliance.org/ncs/ [accessed 4 May 2009].*
- [90]. *National Institute of Building Science (2009) New Version of the United States National CAD Standard® Now Available [home page] Available from: <http://www.nibs.org/newsstory1.html> [accessed 4 May 2009]*
- [91]. *East, E. W. (2007) Construction Operations Building Information Exchange (COBIE) Requirements Definition and Pilot Implementation Standard. US Army Corps of Engineers: Engineering Research Center [online] Available from: <http://www.dtic.mil/cgi-bin/GetTRDoc?AD=ADA491932&Location=U2&doc=GetTRDoc.pdf> [accessed 5 May 2009]*

10 List of Figures

Fig 1: Exporting and importing process between proposed applications.....	24
Fig 2: MicroStation arch behaves differently in “Nemetschek Allplan”	28
Fig 3: Illustrates lost of hatching in Nemetschek Allplan.....	29
Fig 4: Texts and notes exported from MS disappeared in “Allplan”.	30
Fig 5: Annotation elements lost their associated text in Allplan (right).	31
Fig 6: Spline does not look as smooth in Arch. Desktop 3.3	34
Fig 7: Circle does not look as smooth in Arch. 3.3	35
Fig 8: The two cylinders are attached in Arch. Desktop 3.3	36
Fig 9: Cylinders (solid & surface) look the same when rendered in Arch. 3.3	37
Fig 10: “circular filleted” and “chamfered corners” differ in Arch. 3.3	38
Fig 11: Solid slab behaves differently in Arch. 3.3.....	39
Fig 12: Shows sphere’s different appearance in Arch. 3.3.....	40
Fig 13: Arch. 3.3 represents “Cones” wiremesh differently	41
Fig 14: Illustrates lost of dimension association in Arch. 3.3	45
Fig 15: Illustrates the difference in Spline appearance	45
Fig 16: Shows extra information on top of each element in Ms	46
Fig 17: Symbols from Allplan are represented by numbers.....	47
Fig 18: Spline with connection appeared differently in MicroStation	47
Fig 19: Barcode looks different in MicroStation	48
Fig 20: Automatic dimensioning association and accuracy problems	49
Fig 21: Stairs exported from Allplan to MS included hiding information.....	50
Fig 22: “Allplan” wall unit accepts “Arch. 3.3” rendering command	54

Fig 23: illustrates the difference in wall unit at bottom	54
Fig 24: Nemetschek Allplan “Spline” works as one unit.....	55
Fig 25: Arch. 3.3 “Spline” behaves as separate elements and modified differently	55
Fig 26: Shows the difference in braces at bottom	56
Fig 27: Extra information introduced in all views in “Arch.3.3”	56
Fig 28: Extra data and falls “wiremesh” presentation of elements.	57
Fig 29: Sphere imported from Arch.3.3 to MS in different stages	59
Fig 30: 3D shapes falsely represented and did not render in MicroStation.	60
Fig 31: Hatching imported from Arch.3.3 to Allplan look different.	62
Fig 32: Illustrates the loss of hatching association.....	63
Fig 33: Arch. 3.3 Spline is modified differently in Nemetschek Allplan	63
Fig 34: “Architectural Desktop” 3D elements cannot be rendered by “Allplan”	64
Fig 35: Examples of Virtual Cities on the WWW	71
Fig 36: A small section of 2D plan of Hashtgerd Newtown	73
Fig 37: 2D section of Hashtgerd after eliminating extra information	74
Fig 38: A photo image of Hashtgerd Newtown	75
Fig 39: the full developed 2D plan of the VRCE.....	76
Fig 40: 2D CAD plan of the Hashtgerd New Town.....	77
Fig 41: 3D models as placed to form the VRCE.....	79
Fig 42: Simple 3D models developed differently to form VREC.....	80
Fig 43: The CAVE (Cave Automatic Virtual Environment)	82
Fig 44: Screen shots of visit to the TU portal	83
Fig 45: A sample of the images created along the walkthrough path	85
Fig 46: Showed snap shots of VRCE video.....	86
Fig 47: Illustrates the process of exporting the VRCE to Google Earth.....	89

Fig 48: Hashtgerd location as presented by Google Earth	90
Fig 49: 2D plan of Hashtgerd as placed on Google Earth.....	91
Fig 50: Visualizing the VRCE in Google Earth.....	93
Fig 51: Visualizing detailed VRCE Models by Google Earth	94
Fig 52: layers and associated data exported to Google earth	96
Fig 53: The “IFC-mBomb” project model diagram.....	119
Fig 54: Single BIM (x1).....	138
Fig 55: BIM (x2).....	138
Fig 56: BIM (x3).....	139
Fig 57: Multiple BIM.....	140
Fig 58: COBIE process overview	154
Fig 59: Military Barracks BIM Model (USACE Honolulu District)	156
Fig 60: Fort Lewis Barracks, Seattle District.....	156
Fig 61: SBA Group new innovative office building (Vilnius, Lithuania).....	158
Fig 62: Computer generated image showing the steel frame (red)	161
Fig 63: Addition to the existing Denver Art Museum	162
Fig 64: Park Hospital in Novi, Michigan	163
Fig 65: BIM consists of architectural, structural and MEP system.....	165
Fig 66: BIM of One Island East (OIE) Project.....	166
Fig 67: 3D structural model	177
Fig 68: 3D architectural model	178
Fig 69: Proposed BIM system Chart.....	179
Fig 70: A sample of rendered photos produced by the BIM system.....	183
Fig 71: Screen shots of the “wiremesh-model” video.....	184
Fig 72: Screen shots of the “ray trace” video of the office building	184

Fig 73: Views of the office model in Google Earth environment.....	189
Fig 74: The BIM is inserted in Acrobat as “pdf” file.....	192
Fig 75: Portion of the “architectural detailed report”.....	198
Fig 76: Architectural Summarized quantity report	199
Fig 77: “grouped architectural quantity report”	200
Fig 78: A portion of the “structural detailed report”	202
Fig 79: Developed “grouped structural quantity report”	203
Fig 80: Architectural produced floor plan and details	206
Fig 81: Architectural produced drawings (sections & details).....	206
Fig 82: Top steel detailing view.....	208
Fig 83: Portion of top steel detailing view produced by BIM.....	209
Fig 84: A vertical section generated from the BIM	209
Fig 85: 3D models produced by the BIM within pdf. file.....	210
Fig 86: Illustrates proposed BIM system architecture	211
Fig 87: Categorizing the BIM system outputs	214
Fig 88: BIM system results for Architects	216
Fig 89: BIM system results for Structural Engineers.....	217
Fig 90: Illustrates changing or modifying process.....	219
Fig 91: Illustrates a typical BM system architecture.....	222

11 List of Tables

Table (1) Exporting elements from MicroStation to Nemetschek Allplan	27
Table (2) Exporting elements from MicroStation to Arch. Desktop 3.3.....	33
Table (3) Exporting elements from Nemetschek Allplan to MicroStation	44
Table (4) Exporting elements from Nemetschek Allplan to Arch.3.3	53
Table (5) Exporting elements from Arch.3.3 to MicroStation V8	58
Table (6) Exporting elements form Arch. 3.3 to Nemetschek Allplan	61